

P-ROV-514/01

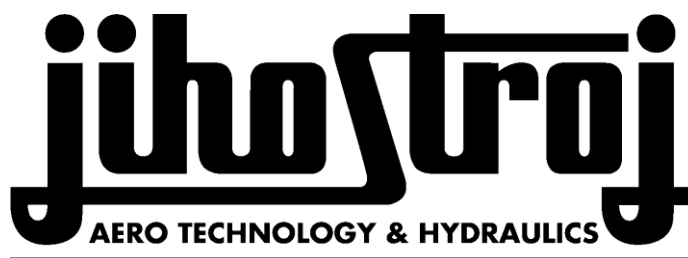

ATA 61-25-14

OPERATION AND INSTALLATION MANUAL
FOR
CONSTANT SPEED
PROPELLER GOVERNORS
P-AB0-X/A
P-AB0-X/B

ADJUSTABLE HEAD TYPE

CAUTION

Any governor installed on an engine that is involved in a sudden stoppage incident must be overhauled or exchanged. Due to the abnormally high loads imposed by sudden stoppage, the subject governor must be tagged that it was involved in such an incident for the information of the overhauling agency.

WARNING

Failure to follow instructions herein can cause personal injury and/or property damage.

WARNING

This manual must remain with the governor in case of sale. This document, technical data and the information contained therein are property of JIHOSTROJ a.s. and must not be reproduced, neither in entirety nor partially, and passed on to third parties without previous consent in writing by JIHOSTROJ a.s. This text must be written on every complete or partial reproduction.

NOTE

The operating instructions detailed in this manual do not alter or supersede the recommendations of the aircraft or engine manufacturer unless they are part of the flight manual supplement required by a supplemental type certificate.

NOTE

This manual contains PROPELLER GOVERNOR LOG. Record all works performed with governor into this PROPELLER GOVERNOR LOG. To do so helps you and your service centre to maintain, repair and overhaul your governor. When asking help at you service centre submit always completed LOG.

CONTENTS

CONTENTS.....	003
LIST OF EFFECTIVE PAGES.....	004
LIST OF EFFECTIVE REVISIONS.....	005
1. GENERAL.....	101
2. GOVERNOR DESIGNATION.....	201
3. SPECIFICATION.....	301
4. DESIGN AND OPERATION INFORMATION.....	401
5. INSTALLATION AND OPERATION INSTRUCTION.....	501
6. INSPECTION.....	601
7. TROUBLE SHOOTING.....	701
8. SHIPPING AND STORAGE.....	801
9. PROPELLER GOVERNOR LOG.....	901

LIST OF EFFECTIVE PAGES

Page	Revision	Date of issue	Page	Revision	Date of issue
001	a	30.5.2002			
002	a	30.5.2002			
003	a	30.5.2002			
004	c	20.8.2004			
005	c	20.8.2004			
101	c	20.8.2004			
201	c	20.8.2004			
301	b	14.5.2003			
401	c	20.8.2004			
402	a	30.5.2002			
403	a	30.5.2002			
501	c	20.8.2004			
502	c	20.8.2004			
503	c	20.8.2004			
504	c	20.8.2004			
505	c	20.8.2004			
601	a	30.5.2002			
701	c	20.8.2004			
702	c	20.8.2004			
801	a	30.5.2002			
901	c	20.8.2004			
1001	b	14.5.2003			

1. GENERAL

The P-AB0-X/A and P-AB0-X/B propeller governors are single acting governors developed for variable pitch propellers.

1.1 APPLICATION

This publication provides operation, installation and troubleshooting information for the governors P-AB0-X/A and P-AB0-X/B in the following text called as governors.

Installation, removal, operation and trouble shooting information are included in this publication. However, the aircraft manufacturer's manuals should be used along with this information.

1.2 DEFINITION OF COMPONENT LIFE AND SERVICE

1.2.1 Overhaul

Overhaul is a periodic process and contains the following items :

- disassembly
- inspection of parts
- reconditioning of parts
- reassembly

The overhaul interval is based on hours of service (operating time) or on calendar time.

At such specified periods, the governors should be completely disassembled and inspected for cracks, wear, corrosion and other unusual or abnormal conditions. As specified, certain parts should be refinished, and other parts should be replaced.

The overhaul interval (TBO)¹⁾ for the governors is 2000 hours or 7 years if not altered by governor, engine or aircraft manufacturer. The exact value is stated and confirmed in governor's Quality Certificate.

¹⁾ This period includes both storage period and operation period

1.2.2 Repair

Repair is correction of minor damage caused during normal operation. It is done as required.

1.2.2.1 A repair does not include an overhaul.

1.2.2.2 Amount, degree and extend of damage determines whether or not a governor can be repaired without overhaul.

1.2.3 Component life

Component life is expressed in terms of total hours of service (TT, or Total Time) and in terms of hours, of service since overhaul (TSO, or Time Since Overhaul).

Both references are necessary in defining the life of the components. Occasionally a part may be "life limited", which means that it must be replaced after a specified period of use.

Overhaul returns the component or assembly to zero hours TSO (Time Since Overhaul), but not to zero hours TT (Total Time).

No life limit is established for the governors.

2. GOVERNOR DESIGNATION

2.1 MODEL DESIGNATION

P	-	A	B	C	-	X	/	Y
P	-	9	1	0	-	010	/	A
1		2	3	4		5		6

- 1 P = Propeller Governor
- 2 A = Internal Jihostroj marking
- 3 B = Basic design arrangement:
 - 1 = I,CW (pressure to increase pitch, CW rotation facing governor base)
 - 2 = I,CCW (pressure to increase pitch, CCW rotation facing governor base)
 - 3 = D,CW (pressure to decrease pitch, CW rotation facing governor base)
 - 4 = D,CCW (pressure to decrease pitch, CCW rotation facing governor base)
- 4 C = Special design arrangement :
 - 0 = Standard
 - 4 = Connector for accumulator
- 5 X = Application number defining settings of governor – relief valve pressure, max. RPM, control arm travel and position
- 6 Y = Control head model:
 - A = Axial, adjustable type head - short
 - B = Axial, adjustable type head – long

It is permissible to use combination of letters and numbers. The first character defines basic model of control head. Following characters specifies design or other deviations within basic design of the control head.
 e.g. AL = Axial, adjustable type head – short, left hand cover control

2.2 SERIAL NUMBER

S/N: 01 1 006
 1 2 3

- 1 Year of Manufacture
- 2 Quarter of the year
- 3 Consecutive Number

3. SPECIFICATION

3.1 PERFORMANCE DATA

Range of acceptable operation temperature
 Range of acceptable operation fluid temperature at the governor inlet

from -25°C (-13°F) to $+125^{\circ}\text{C}$ ($+257^{\circ}\text{F}$)

from -25°C (-13°F) at engine start
The breakaway torque at this temperature must not exceed 40 Nm and the engine oil must be liquid.

Range of altitude
 Operation fluid
 Oil pressure at the inlet governor channel
 Engine oil titration
 Weight

from $+55^{\circ}\text{C}$ ($+131^{\circ}\text{F}$) to $+80^{\circ}\text{C}$ ($+176^{\circ}\text{F}$)
 from -300 m (FL -10) to $10\,700\text{ m}$ (FL 350)
 AEROSHELL W100 engine oil or equivalent
 from 0.2 MPa (29 PSI) to 0.5 MPa (73 PSI)
 30 μm and better
 1.0 kg (2.2 lb) P-AB0-X/A
 1.06 kg (2.34 lb) P-AB0-X/B

The weight is only informative value of basic model without brackets and another installation hardware, concrete value is specified at GAD.

3.2 DIMENSIONS

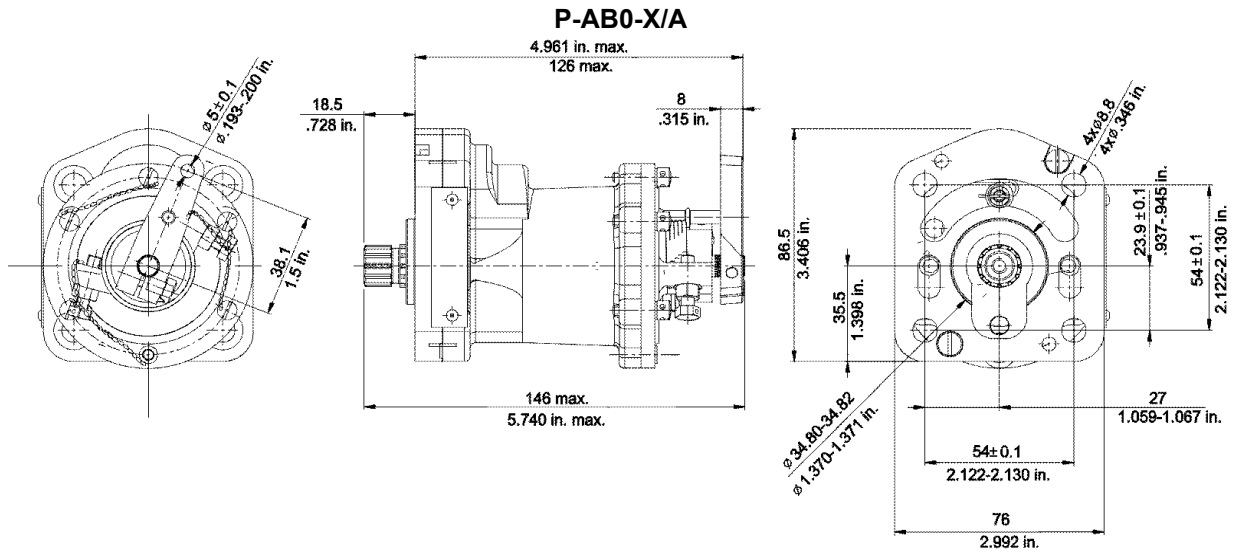

Fig. 301

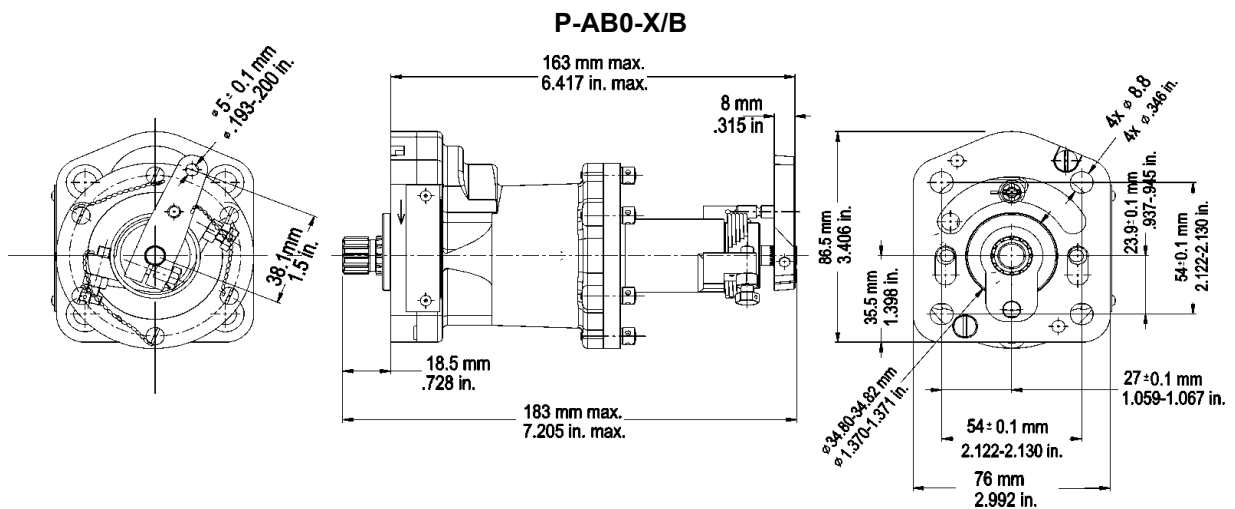

Fig. 302

4. DESIGN AND OPERATION INFORMATION

4.1 DESIGN DESCRIPTION

The Jihostroj a.s. aircraft propeller governors are base mounted centrifugal governors for use with hydraulic constant speed propellers on single or twin engine aircraft. They control aircraft engine speed by continual varying the pitch of the propeller to match propeller torque (and, hence, engine load) to engine developed torque as changes occur in flight conditions. The governors are single-acting using engine oil pressure either to increase or decrease pitch. Pitch change in the opposite direction is accomplished by the force of the propeller blade twisting moment and servo spring, or propeller counterweights.

The pilot valve plunger used is balanced with the flyweights to eliminate axial movement of the plunger due to engine vibration parallel to the axis of the plunger. This feature increases governing stability on engines with lateral vibration characteristics.

The principle parts of each governors are a gear-type oil pump with pressure relief valve, flyweights pivoted on a rotating flyweight head, a spring-loaded pilot valve positioned by the flyweights, an external control lever that varies the spring load on the pilot valve.

The body, cover and base are made of aluminium. The body contains the necessary passage to channel oil to the propeller pitch changing mechanism, and the base is designed to fit the standard AND 20010 engine pad.

4.2 OPERATION DESCRIPTION

The sensing element of the governor is a set of pivoted flyweights mounted on a rotating flyweight head and linked mechanically to the engine gears, through a hollow drive gear shaft.

The flyweights, actuated by the centrifugal force developed by the speed of the rotation, position a pilot valve so as to cover or uncover ports in the drive gear shaft and regulate the flow of oil to and from the pitch changing mechanism of the propeller. The centrifugal force exerted by the flyweights is opposed by the force of an adjustable speeder spring. The load exerted by the speeder spring determines the engine RPM required to develop sufficient centrifugal force in the flyweights to center the pilot valve. Oil to operate the propeller's pitch changing mechanism is supplied by a gear-type oil pump at a pressure value limited by a relief valve.

ON SPEED

In this condition the forces action on the engine-governor-propeller combination are in a state of balance. The speed adjusting control lever has been set by the pilot to obtain the desired engine RPM.

The propeller blades are at the correct pitch to absorb the power developed by the engine. The centrifugal force of the rotating flyweights exactly balances the force of the speeder spring with the flyweights in the vertical position. The pilot valve is positioned in the drive gear shaft, so that the control ports between the oil pump and the propeller pitch changing servo are covered. Pressure oil from the gear pump is circulated through open governor relief valve back to the inlet channel of the pump.

OVERSPEED

This condition occurs when airspeed or horsepower is increased and engine RPM increases above the rate called for by the setting of the speed adjusting control lever. The rotating flyweights pivot outward as their increased centrifugal force overcomes force exerted by the speeder spring.

Counterweighted Propeller using Pressure to Decrease Pitch (see Fig. 401)

The flyweight toes raise the pilot valve plunger, uncovering ports in the driver gear shaft that permit pressure oil to flow from the propeller pitch changing mechanism. This allows propeller counterweights to take the propeller blades towards a higher pitch. The load on the engine is increased and engine speed is reduced.

Propeller using Pressure to Increase Pitch (see Fig. 402)

The flyweight toes raise the pilot valve plunger, uncovering ports in the driver gear shaft that permit pressure oil to flow to the propeller pitch changing mechanism. This moves the propeller blades to a higher pitch and load on the engine is increase and engine speed is reduced.

This, in turn, lessens centrifugal force exerted by the flyweights in opposition to the force of the speeder spring. The flyweights return to a vertical position and the pilot valve plunger once more covers ports in the drive gear shaft, blocking flow of pressure oil to or from the pitch changing mechanism of the propeller.

UNDERSPEED

An underspeed condition occur when the airspeed or horsepower is decreased and engine RPM falls below the rate established by the setting of the speed adjusting control lever. The decrease in the centrifugal force of the rotating flyweights causes them to pivot inward under the force exerted by the speeder spring.

Counterweighted Propeller using Pressure to Decrease Pitch (see Fig. 401)

The pilot valve plunger is forced down uncovering the ports in the drive gear shaft that allow pressure oil to flow to the pitch changing mechanism of the propeller. This overcomes the force of the propeller counterweights and decreases the pitch of the propeller blade.

Propeller using Pressure to Increase Pitch (see Fig. 402)

The pilot valve plunger is forced downward, uncovering the ports in the driver gear shaft, thus allowing oil to flow from the pitch changing mechanism of the propeller to sump. This permits the centrifugal twisting moment of the blades to decrease propeller pitch.

This reduce the load on the engine, thereby increasing engine speed and the centrifugal force developed by the rotating flyweights. The flyweight toes lift the pilot valve plunger to cover the control ports. At this point the forces acting on the engine-governor-propeller combination are again balanced at the engine is back to the speed called for by the governor setting.

NOTE :

LOSS OF OIL FROM THE PROPELLER PITCH CHANGING MECHANISM DUE TO ENGINE TRANSFER RING LEAKAGE WILL RESULT IN CHANGED SPEED SETTINGS.

Pressure to decrease pitch Type Pilot Valve

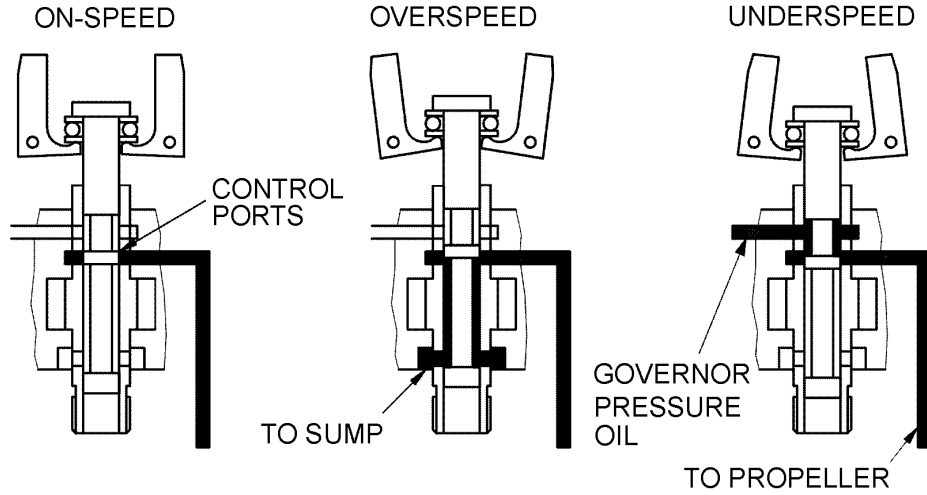

Fig. 401

Pressure to increase pitch Type Pilot Valve

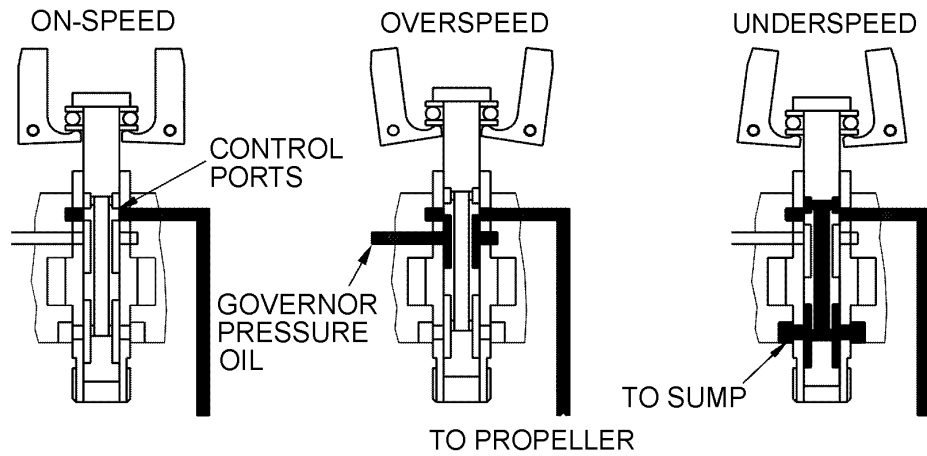

Fig. 402

5. INSTALLATION AND OPERATION INSTRUCTION

- 5.1 Prepare new mounting gasket. Coat gasket with engine oil or equivalent before installation.
- Check that mounting studs project a minimum of 31.75 mm (1.250 in.) from face of engine pad.
 - Clean engine pad, studs and mounting hardware before installing new mounting gasket. Ensure governor drive spline mate correctly with engine accessory drive spline.
 - Attach mounting hardware and torque the (4) mounting nuts to 11-15 Nm (97-133 in.Lbs).
 - Reconnect push-pull control to outermost hole on governor control lever and adjust linkage per aircraft service information.
 - Flight check aircraft for proper RPM setting. Record amount of change required and different flight conditions. Test should be done in smooth air.
 - If adjustment is required, remove cowling, cut lockwire, loosen jam nut and turn max RPM screw clockwise or counterclockwise – see section 5.5.
 - Also check for oil leaks – none permitted.

WARNING :

SUPPLY OIL AT THE GOVERNOR INLET MUST BE FREE OF AIR WITHIN A PRESSURE RANGE SPECIFIED IN SECTION 3.1. AIR IN ENGINE OIL WILL CAUSE PRESSURE PULSATION AT PUMP OUTLET WHICH COULD DAMAGE EITHER SOME OF GOVERNOR'S PARTS OR TO CUT DOWN GOVERNOR'S OPERATION LIFE SUBSTANTIALLY.

5.2 PERFORM STATIC RUN-UP

ATTENTION : PERFORM THE STATIC RUN-UP ON A CLEAN AREA, TO NOT DAMAGE THE PROPELLER BLADES DUE TO STONES ETC.

Lock aircraft brakes. Place cockpit propeller RPM lever in high position. Advance throttle slowly to maximum permitted engine manifold pressure limits. Record propeller RPM. If local wind conditions are over 2.5 m/s, 5 knots repeat check with aircraft pointed to opposite direction and average two numbers. As a general rule, propeller should be 25-100 RPM below the red line limit during check.

PULL BACK THE PROPELLER LEVER 3 TO 5 TIMES TO REMOVE AIR IN THE SYSTEM.

5.3 PERFORM FLIGHT TEST

During take-off acceleration, record maximum propeller RPM. When sufficient altitude is reached, level out aircraft, leaving propeller control in full RPM position. Maintain this setting for 3 to 5 minutes while monitoring propeller RPM. Following this check, two conditions may exist which require adjustment :

- 5.3.a** If the propeller RPM is exceeding the redline limit, reduce it to the redline using propeller control. Leaving propeller on this redline RPM setting, land aircraft and shutdown. Remove cowling and note position of control arm and governor. Adjust governor high RPM screw clockwise so it just touches stop on governor control arm; this will ensure that the correct arm position for governor redline RPM setting cannot be exceeded.
- 5.3.b** If the propeller is bellow red line limit with max RPM setting on the propeller cockpit control, note RPM and land. Remove engine cowling and adjust the governor high RPM screw counterclockwise to increase of approximately 25 RPM. Perform another flight to confirm if adjustment were sufficient.
Remove engine cowling and check for the oil leaks. Oil leaks aren't permitted.
Make a record in governor log.

5.4 GENERAL

Static Run-up

There has been some confusion in the field concerning propeller low blade angle setting, the governor setting and how it relates to static run-up and take-off RPM.

As a general rule, engine redline RPM cannot be reached during a full power static run-up. Contrary to popular belief, the governor is not controlling the propeller at this time, the propeller is against its low pitch stop. Attempting to increase propeller static run-up RPM by adjusting the governor high RPM screw will have no effect and will probably result in a propeller overspeed during the take-off roll.

5.5 CALIBRATION PROCEDURE

Tools: pliers, torque wrench, screwdriver, 8 mm (5/16") wrench, lockwire wrench, lockwire \varnothing 0.5-0.7 mm (0.02-0.03 in.) material X10CrNiTi18 10 or AMS 5687.

5.5.a Adjusting position of the control lever (see Fig. 501)

Remove lockwire from screws at cover flange.
Loose 6 x screws at the cover flange.
Turn the control head to an appropriate position.
Torque 6 x screws to 1.6-1.8 Nm (14.2-15.9 in.lbs).
Install new lockwire.

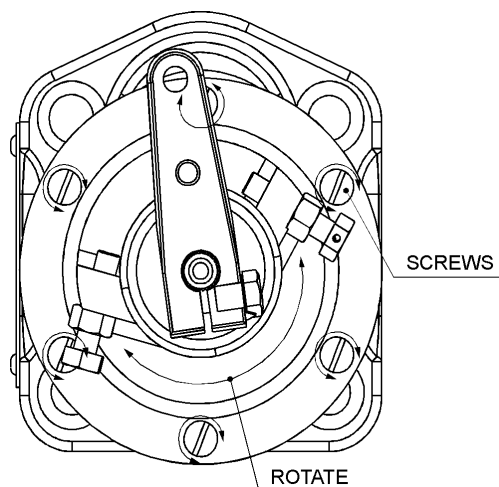

Fig. 501

5.5.b Adjusting maximum propeller RPM (see Fig. 502)

Remove lockwire from the maximum RPM stop screw and turn control lever to the maximum RPM stop.

Set maximum propeller's RPM by turning the stop screw. One full turn clockwise will reduce RPM by approximately 25-50 RPM. One full turn counterclockwise will increase RPM by approximately 25-50 RPM.

If the requested RPM cannot be reached, the control lever must be repositioned.

- 1) Loose and remove screw from the control lever.
- 2) Remove the control lever and turn it to an appropriate position again. Clockwise direction to decrease of maximum propeller RPM (resp. increase at left hand cover type) or counterclockwise to increase of maximum propeller RPM (resp. decrease at left hand cover type).
- 3) Torque screw to 4.6-5.0 Nm (40.7-44.3 in.lbs). Lock safety washer.
- 4) If necessary adjust control head position in accordance with item 5.6.a.

Torque the jam nut of maximum RPM stop screw to 2.8-3.2 Nm (24.8-28.3 in.lbs) and lockwire the stop screw.

ATTENTION : AFTER ADJUSTMENT, THE MAX. RPM STOP SCREW MUST OVERLAP THE STOP SCREW SUPPORT AT LEAST 1 MM (0.04 INCHES) (see Fig. 502).

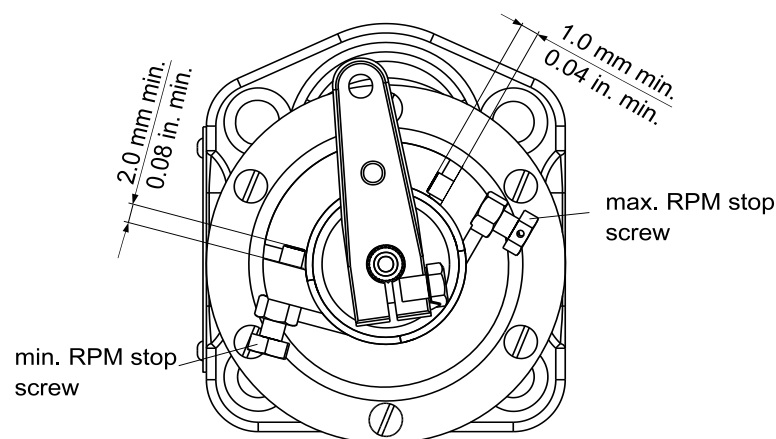

Fig. 502a Right hand cover

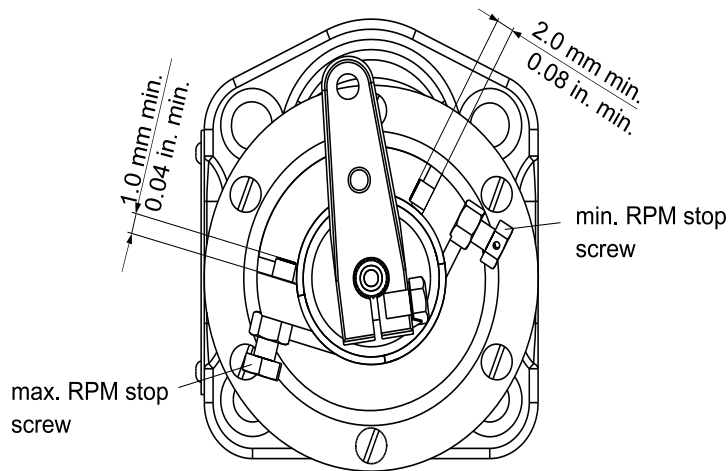

Fig. 502b Left hand cover

Assure that the distance between the end of shaft in position lever α_{max} and between governor housing is greater than values at Fig. 503 (a, b), otherwise the O-ring will be damaged. Fig. 503a shows version without extended control shaft. Fig. 503a shows version with extended control shaft applicable for bracket. This will result in an oil leakage. In case of doubt, contact service center or governor manufacturer.

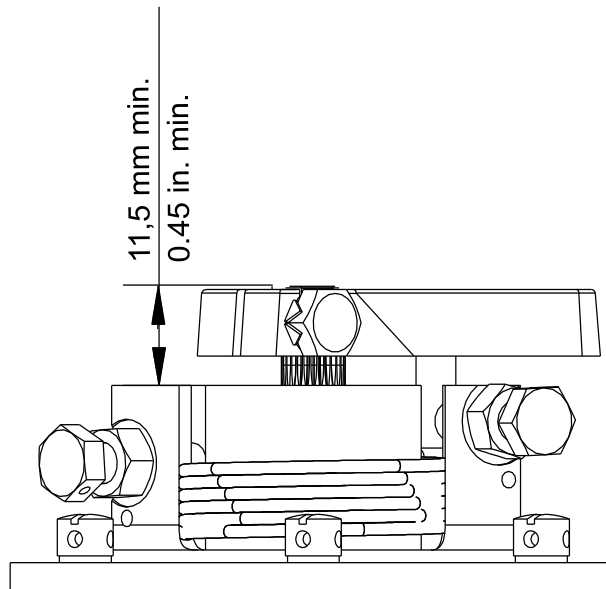

Fig. 503 a Cover with not extended shaft

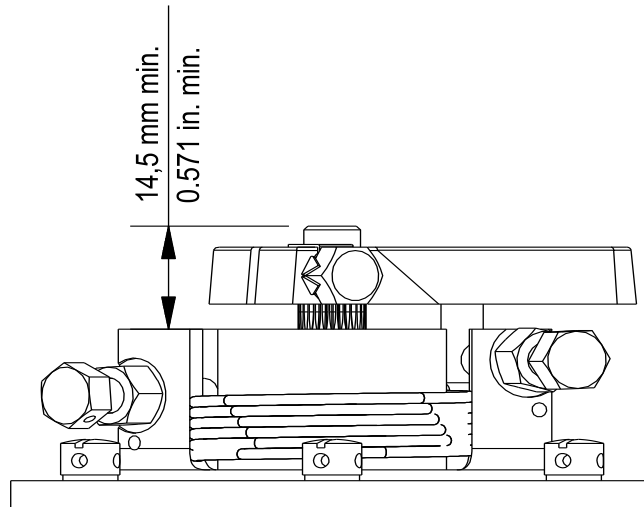

Fig. 503 b Cover with extend shaft applicable for bracket

5.5.c Adjusting minimum propeller RPM (see Fig. 502)

Remove safety wire from the minimum RPM stop screw and turn control lever to the minimum RPM stop.

Set minimum propeller's RPM by turning the stop screw. One full turn clockwise will increase RPM by approximately 25-50 RPM. One full turn counterclockwise will reduce RPM by approximately 25-50 RPM.

Torque the jam nut of minimum RPM stop screw to 2.8-3.2 Nm (24.8-28.3 in.lbs) and lockwire the stop screw.

ATTENTION : AFTER ADJUSTMENT, THE STOP SCREW MUST OVERLAP THE STOP SCREW SUPPORT AT LEAST 2 MM (0.08 INCHES) (see Fig. 502).

5.5.d Governor deinstalation

Remove push-pull linkage in accordance with aircraft service instructions.

Remove mounting nuts and washers.

Pat on the governor to release it and then remove governor from engine pad.

If it is necessary clean governor drive and engine pad by appropriate means.

Record the removal in governor log.

Perform preservation in accordance with section 8.0 to prepare for long term storage.

Storage in accordance with section 8.0.

6. INSPECTIONS

Check for oil leakage at governor's surface and a mounting pad.

If oil leakage is detected check stop nuts at the governor housing and the mounting nuts. Torque if necessary. If oil leakage is detected repeatedly contact service center or governor's manufacturer.

WARNING : NO OIL LEAKAGE IS PERMITTED.

7. TROUBLE SHOOTING

7.1 PROPELLER SURGING – POSSIBLE CAUSES:

7.1.1 Excessive transfer bearing leakage

Engines with excessive transfer bearing leakage can experience propeller surging since the governor may not be able to get enough oil pressure to the propeller.

Solution : Perform a transfer bearing leakage test per engine manufacturer's instructions. If test indicate a high rate of leakage (even through it may still be on the high side of "acceptable" tolerance), this maybe the cause. Install the suspect governor on a known "good" aircraft. If problem disappears, engine work may be indicated.

7.1.2 Malfunctioning magnetos

7.1.3 Dirty engine oil

Contaminants in dirty engine oil can cause blockage of close tolerance passages in governor, leading to erratic operation.

Solution : Flush the governor in order to cleaning out contaminated oil.

7.1.4 Excessive "play" in aircraft propeller control linkage

Excessive "play" in the linkage between the governor and the cockpit control often leads to erratic operation. Specifically, if the propeller RPM is suddenly changing and holding a new setting of its own, this could indicate loose linkage.

Solution : Trace linkage and locate unsecured sections and tighten-up as needed. Please note that although linkage may appear to allow full governor control while the engine is off, it may not in the air. Engine vibration and "stretch" of the mount during operation can often aggravate the condition. Therefore, it is important the entire length of linkage be properly secured, even if the ends alone are tight.

7.1.5 Excessive propeller friction

(NOTE : This is rarely the cause of RPM malfunction.)

Propeller may be overly-resistant to pitch movement. This can be caused by either excessively shimming of the propeller blades, or internal corrosion or part failure, causing binding.

Solution : Check amount of propeller blade "play" as defined in the propeller manufacturer's operating manuals.

7.2 RPM DRIFT – POSSIBLE CAUSES:

7.2.1 Internal oil leakage

Governor unable to reach sufficient control pressure.

Solution : Contact propeller governor service center for governor internal leak test.

7.2.2 Extremely high temperature

Extremely high temperature changes oil viscosity. The governor may not reach sufficient control pressure.

Solution : Check oil temperature. Correct cause of high temperature.

7.2.3 Governor wear

Excessive wear of internal parts.

Solution : Contact governor service center for bench test.

7.3 GOVERNOR SEIZURE – POSSIBLE CAUSES:**7.3.1 Pollution of engine oil**

Excessive dirt in the engine oil pollution can cause governor seizure.

Solution : Overhaul the governor.

7.4 GOVERNOR DRIVE FAILURE – POSSIBLE CAUSES:**7.4.1 Engine drive vibration**

Excessive engine vibrations can cause governor drive failure.

Solution : Overhaul the engine and the governor.

8. SHIPPING AND STORAGE

Conservation

Inner conservation is done by flushing governor with engine oil.

NOTE : WHEN CONSERVATING GOVERNOR USE NEW ENGINE OIL OR LUBRICATING OIL MIL-L-6082 OR EQUIVALENT.

WARNING : DON'T STORE GOVERNOR WITHOUT INNER CONSERVATION FOR MORE THAN 24 HOURS!

After installing the governor the conservation is done together with engine in accordance with the instruction of the engine manufacturer.

Outside conservation isn't required.

For storage longer than 1 week pack the governor in two layers of wax-cloth and put it in a plastic bag together with appropriate charge of drying agent. The plastic bag should be then vacuumed and welded.

Make a note in the PROPELLER GOVERNOR LOG.

Deconservation isn't needed.

Storage

Protect governor from physical damage by storing in an suitable area.

Store governors in temperature from +10°C (+50°F) to +30°C (+86°F) and relative humidity from 40 % to 80 %. Keep stock room free of gases with deleterious effect and dirt.

JIHOSTROJ a.s.
Aero Technology Division
Budějovická 148
382 32 Velešín
Czech Republic

Tel: 00420 / 380 / 340511
Fax: 00420 / 380 / 340612
E-mail: sales.ad@jihostroj.cz
[http: www.jihostroj.cz](http://www.jihostroj.cz)