

jühstroj

AERO TECHNOLOGY & HYDRAULICS

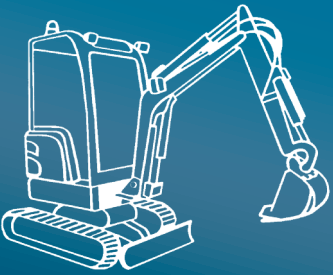

Displacement from 0.18 to 3.20 ccm
Pressure up to 230 bar
Speed from 800 to 8000 RPM

GEAR PUMPS

X

TABLE OF CONTENTS

DESCRIPTION.....	2
BASIC PARTS OF PUMP.....	2
PARAMETER TABLE.....	3
FORMULAS USED FOR CALCULATION.....	4
PUMP EFFICIENCIES.....	4
WORKING LIQUID.....	5
PRESSURE LOAD.....	5
DIRECTION OF ROTATION.....	6
REVERSIBLE DESIGN.....	6
X FLOW RATE AND POWER CURVES.....	7
ORDER KEY.....	13
COMBINATIONS OF FLANGES AND SHAFTS.....	14
FLANGE DESIGN.....	14
DRIVE SHAFTS.....	15
LIQUID INLET AND OUTLET CONNECTION.....	16
CATALOGUE SHETS OF X SERIES BASIC DESIGNS.....	17
NOTES.....	23

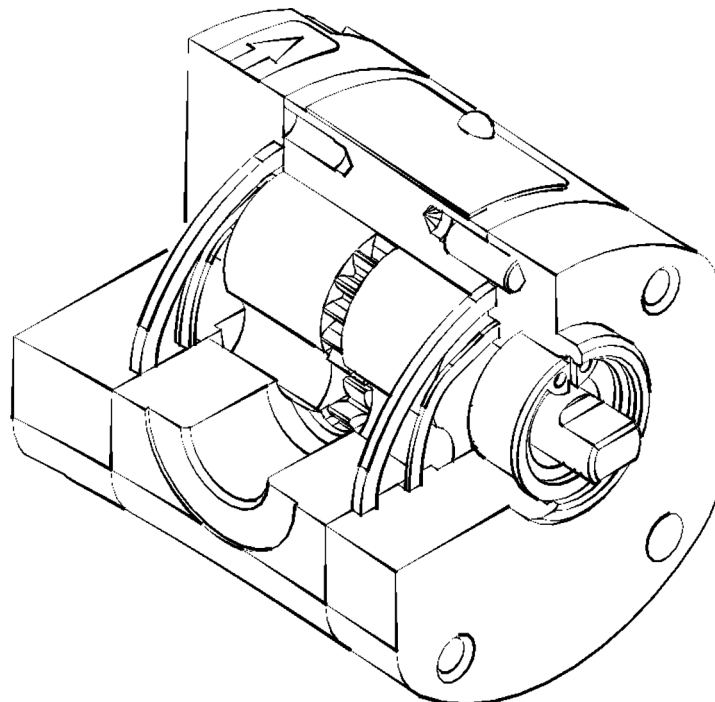

DESCRIPTION

- Pumps and motors of X series are designed for use in hydraulic systems with very low performance (up to 2.3 kW). They are produced in unidirectional and bi-directional design.
- A wide range of shafts, flanges, inlets and outlets working liquid allows their use in hydraulic circuits stationary and mobile machines and devices of smaller dimensions. The used types of connections and flanges conform to world standards.
- The X series have a wide spectrum of usable rotational speed from 800 to 8000 min⁻¹, enabling connection to high-speed motors. Pumps and motors have a very favourable efficiency and noise throughout the rev range and pressure.

BASIC PARTS OF PUMP

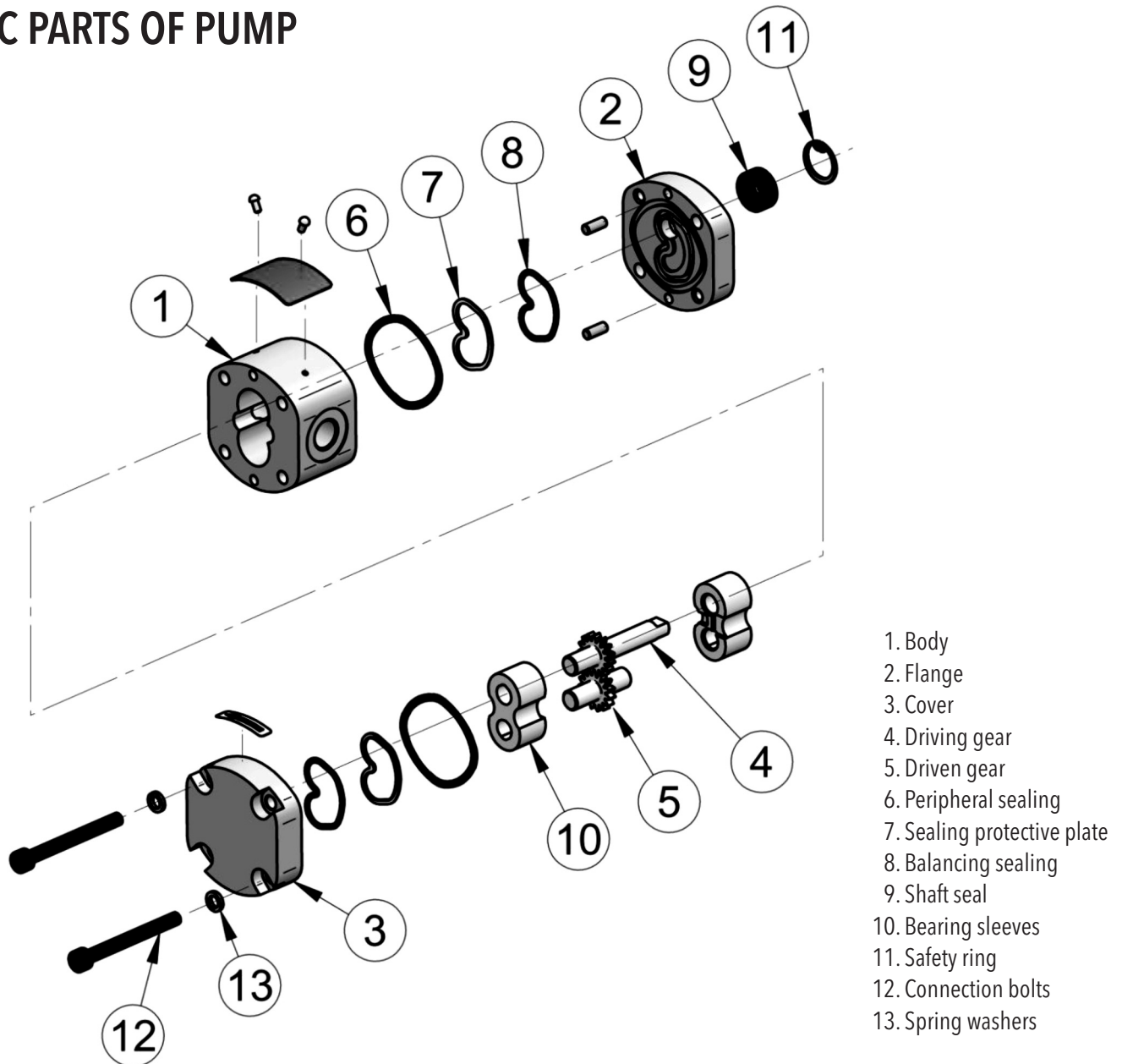

PARAMETER TABLE

Nominal Size Parameters		Sym.	Unit.	X 0.18	X 0.25	X 0,32	X 0,36	X 0.40	X 0.50	X 0.63	X 0.70
Actual displacement		V_g	[cm ³]	0.175	0.256	0.327	0.361	0.408	0.501	0.630	0.711
Rotation speed	nominal	n_n	[min ⁻¹]	1500	1500	1500	1500	1500	1500	1500	1500
	minimum	n_{min}	[min ⁻¹]	1000	1000	1000	1000	1000	1000	1000	1000
	maximum	n_{max}	[min ⁻¹]	8000	7000	7000	7000	7000	6000	6000	6000
Pressure at inlet*	minimum	p_{1min}	[bar]	-0.3	-0.3	-0.3	-0.3	-0.3	-0.3	-0.3	-0.3
	maximum	p_{1max}	[bar]	0.5	0.5	0.5	0.5	0.5	0.5	0.5	0.5
Pressure at outlet**	max. continuous	p_{2n}	[bar]	200	230	230	230	230	230	220	220
	maximum	p_{2max}	[bar]	250	250	250	250	250	250	240	240
	peak	p_3	[bar]	260	260	260	260	260	260	250	250
Nominal flow rate (min.) at n_n and p_{2n}		Q_n	[dm ³ .min ⁻¹]	0.19	0.30	0.40	0.44	0.50	0.65	0.85	0.95
Maximum flow rate at n_{max} a p_{2max}		Q_{max}	[dm ³ .min ⁻¹]	1.39	1.77	2.27	2.50	2.83	2.98	3.74	4.22
Nominal input power (max.) at n_n and p_{2n}		P_n	[kW]	0.10	0.17	0.22	0.24	0.28	0.34	0.41	0.46
Maximum input power at n_{max} a p_{2max}		P_{max}	[kW]	0.69	0.88	1.12	1.24	1.40	1.4	1.78	2.01
Weight		m	[kg]	0.37	0.38	0.38	0.38	0.39	0.39	0.40	0.40

Nominal Size Parameters		Sym.	Unit.	X 0.80	X 1.00	X 1.25	X 1.50	X 2.00	X 2.50	X 3.20
Actual displacement		V_g	[cm ³]	0.804	1.001	1.258	1.514	2.004	2.505	3.192
Rotation speed	nominal	n_n	[min ⁻¹]	1500	1500	1500	1500	1500	1500	1500
	minimum	n_{min}	[min ⁻¹]	1000	800	800	800	600	500	500
	maximum	n_{max}	[min ⁻¹]	6000	5000	4000	3000	2800	2500	1800
Pressure at inlet*	minimum	p_{1min}	[bar]	-0.3	-0.3	-0.3	-0.3	-0.3	-0.3	-0.3
	maximum	p_{1max}	[bar]	0.5	0.5	0.5	0.5	0.5	0.5	0.5
Pressure at outlet**	max. continuous	p_{2n}	[bar]	220	200	200	160	120	90	60
	maximum	p_{2max}	[bar]	240	220	220	180	150	100	70
	peak	p_3	[bar]	240	230	230	190	160	110	80
Nominal flow rate (min.) at n_n and p_{2n}		Q_n	[dm ³ .min ⁻¹]	1.05	1.35	1.70	2.00	2.70	3.40	4.45
Maximum flow rate at n_{max} a p_{2max}		Q_{max}	[dm ³ .min ⁻¹]	4.78	4.95	4.98	4.50	5.56	6.20	5.69
Nominal input power (max.) at n_n and p_{2n}		P_n	[kW]	0.52	0.59	0.74	0.71	0.71	0.66	0.56
Maximum input power at n_{max} a p_{2max}		P_{max}	[kW]	2.27	2.16	2.17	1.60	1.65	1.23	0.79
Weight		m	[kg]	0.40	0.41	0.41	0.43	0.45	0.48	0.53

* Inlet pressure in the reversible design can be up to $p_1 = p_{2n} - 70$ bar max. External drainage must be used in case of the reversible design.

** Outlet pressure in the reversible design is **10% lower** than shown in the table (depending on operating conditions - it is necessary to consult with the manufacturer).

FORMULAS USED FOR CALCULATION

<p>Flow rate Q</p>	$Q = \frac{V_g \cdot n}{1000} \cdot \eta_v \quad [\text{dm}^3 \cdot \text{min}^{-1}]$	<p>V_g [cm³] pump displacement n [min⁻¹] rotation speed η_v [-] volumetric efficiency</p>
<p>Displacement V_g</p>	$V_g = \frac{Q \cdot 1000}{n \cdot \eta_v} \quad [\text{cm}^3]$	
<p>Torque M_k</p>	$M_k = \frac{V_g \cdot p}{20 \cdot \pi \cdot \eta_m} \quad [\text{Nm}]$	<p>p [bar] required pressure at outlet η_m [-] mechanical efficiency</p>
<p>Input power P</p>	$P = \frac{V_g \cdot n \cdot p}{600 \cdot 1000 \cdot \eta_t} \quad [\text{kW}]$	<p>η_t [-] total efficiency</p>

PUMP EFFICIENCIES

<p>Volumetric efficiency η_v</p>	<p>It determines the amount of flow losses. Its value is $\eta_v = 0,92 \div 0,98$ (depending on rotation speed, viscosity of working liquid and outlet pressure). It can be expressed as follows:</p>
	$\eta_v = \frac{Q_{act.}}{Q_{theor}} \quad [-]$
	<p>$Q_{act.}$ [dm³ · min⁻¹] actual flow rate Q_{theor} [dm³ · min⁻¹] theoretical flow rate</p>
<p>Mechanical efficiency η_m</p>	<p>It determines mechanical losses. Its value is about $\eta_m = 0,85$. It can be expressed as follows:</p>
	$\eta_m = \frac{M_{theor}}{M_{act.}} \quad [-]$
	<p>$M_{act.}$ [Nm] actual torque M_{theor} [Nm] theoretical torque</p>
<p>Total efficiency η_t</p>	<p>It is defined as product of η_n and η_m and determines difference between theoretical and actual required input power:</p>
	$\eta_t = \eta_v \cdot \eta_m = \frac{P_{theor}}{P_{act.}} \quad [-]$
	<p>$P_{act.}$ [kW] actual input power P_{theor} [kW] theoretical input power</p>

WORKING LIQUID

- Mineral oils for hydraulic drives
- Hydraulic liquids based on plant oils suitable for hydraulic drives

Liquid temperature

- $t = -20 \div +80$ [°C]
when used with FKM (Viton) seal up to 120 [°C]

Cinematic viscosity

- Recommended (during continuous operation): $\nu = 20 \div 80 \cdot 10^{-6} [\text{m}^2 \cdot \text{s}^{-1}]$
- Maximum (cold starting, at viscosity >1000 , operating pressure <10 bar is permissible, speed $<1500 \cdot \text{min}^{-1}$): $\nu = 1200 \cdot 10^{-6} [\text{m}^2 \cdot \text{s}^{-1}]$
- Minimum (operating mode at $10 \cdot 10^{-6}$ up $20 \cdot 10^{-6}$ should be consulted with manufacturer): $\nu = 10 \cdot 10^{-6} [\text{m}^2 \cdot \text{s}^{-1}]$

Filtration coefficient β_α

$\beta_{25} 75 \geq$ (for pressure $p_2 < 200$ bar)
 $\beta_{10} 75 \geq$ (for pressure $p_2 > 200$ bar)

Liquid contamination class according to ISO 4406

21/18/15 (for pressure $p_2 < 200$ bar)
20/17/14 (for pressure $p_2 > 200$ bar)

Liquid contamination class according to NAS 1638

10 (for pressure $p_2 < 200$ bar)
8 (for pressure $p_2 > 200$ bar)

PRESSURE LOAD

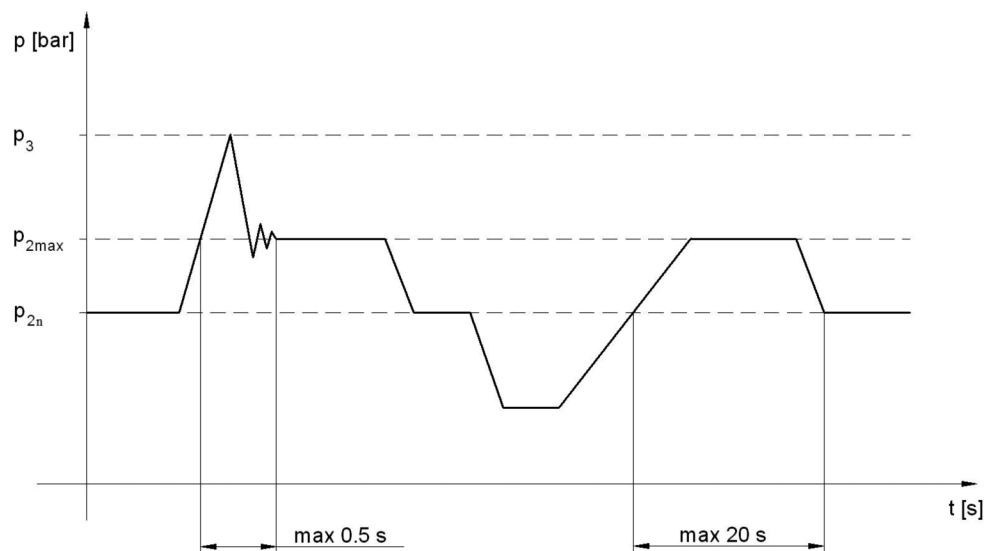

- p_{2n} **max. contin. pressure** Max. working pressure, at which the pump can be operated without time limitation.
- p_{2max} **max. pressure** Maximum pressure permissible for a short time, max. 20s.
- p_3 **peak pressure** Short-time pressure (fractions of a second) arising in case of a sudden change of the operating mode; any excess of this pressure during operation is impermissible.

DIRECTION OF ROTATION

- Determine direction of rotation by looking at the drive shaft. The pump can only be used in the specified direction of rotation.

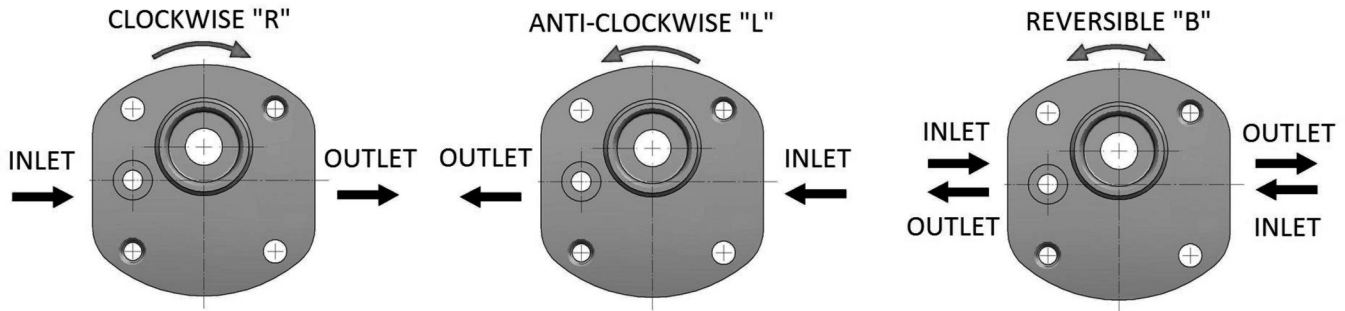

REVERSIBLE DESIGN

- The pumps with the possibility of bidirectional rotation have a different internal arrangement requiring drainage. External drainage is solved by an orifice located in the cover or the flange against the driven gear (see. picture below).

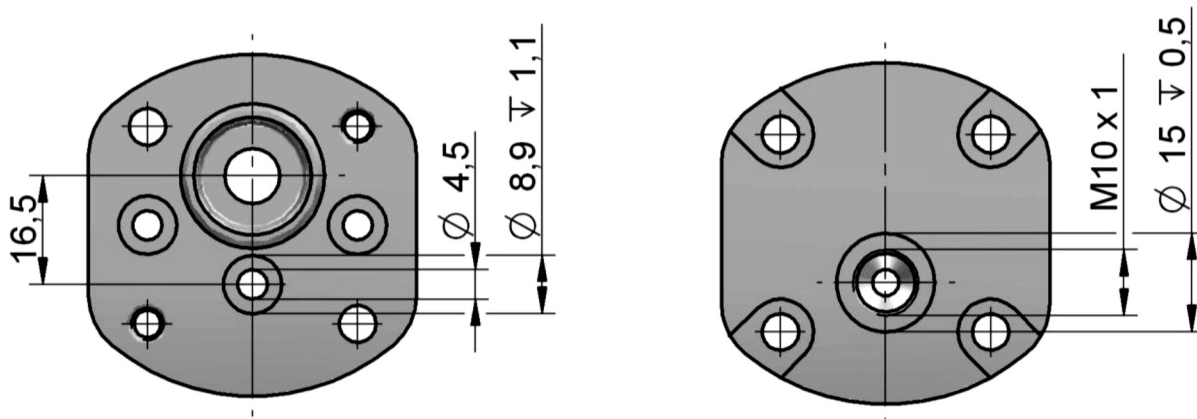

X FLOW RATE AND POWER CURVES

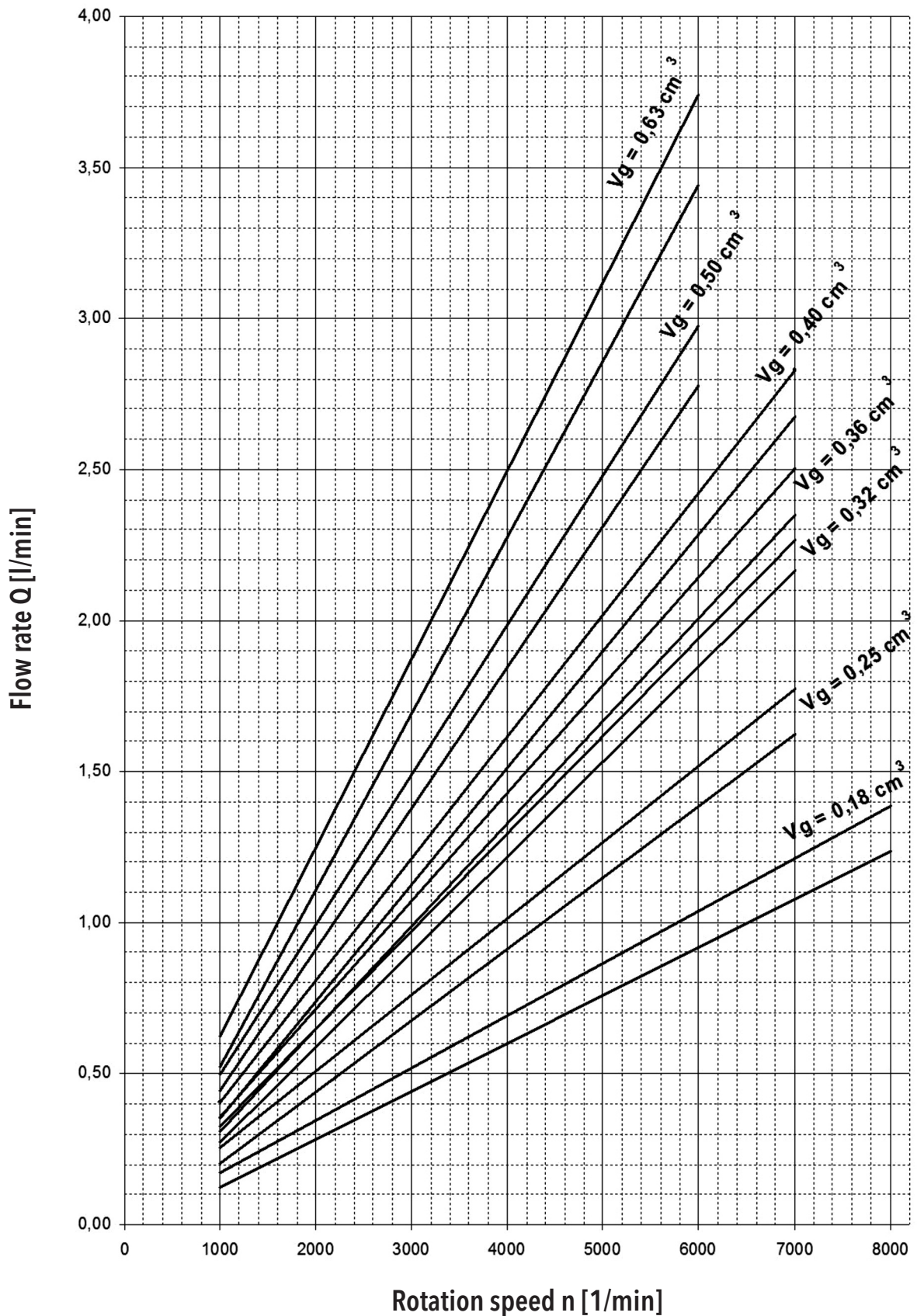

Above curves apply to ISO Vg 46 oil at temperature $t = 45^{\circ}\text{C}$.

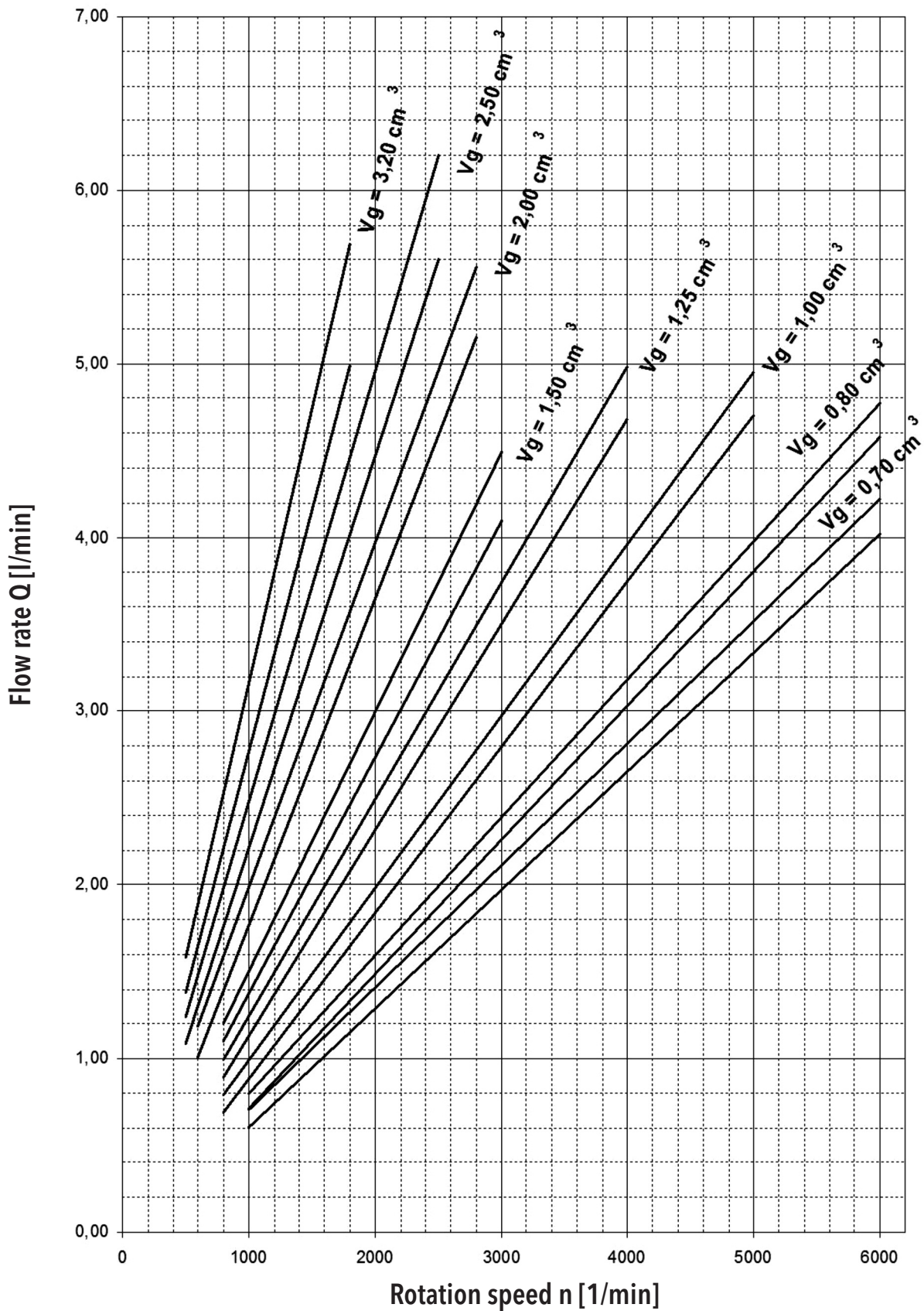

Above curves apply to ISO Vg 46 oil at temperature $t = 45^\circ\text{C}$.

0,18 cm³

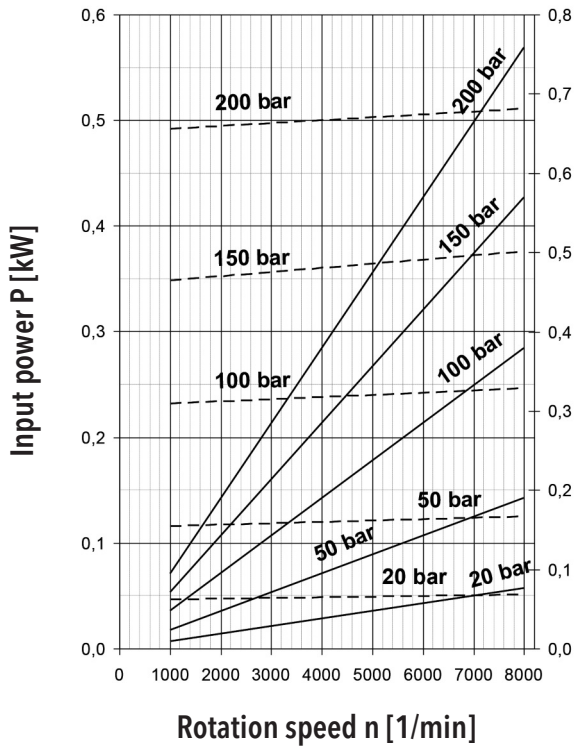

0,25 cm³

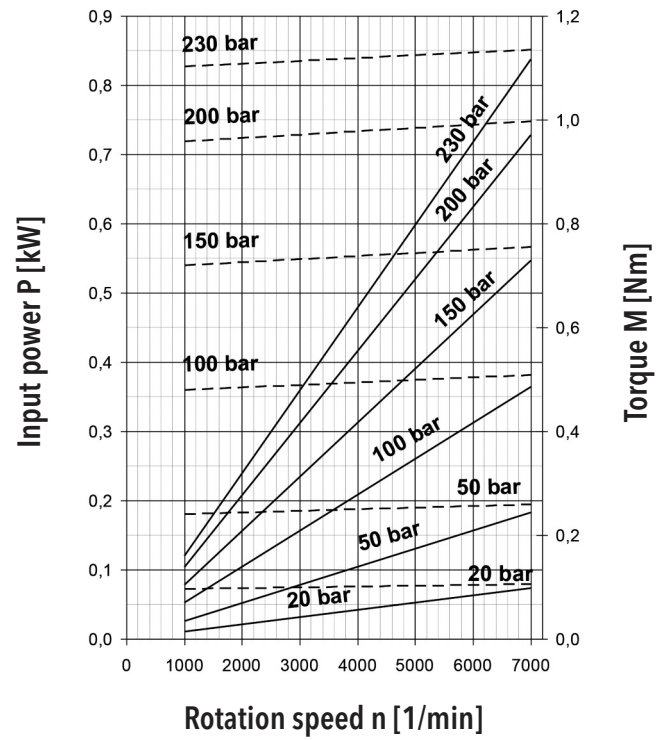

0,32 cm³

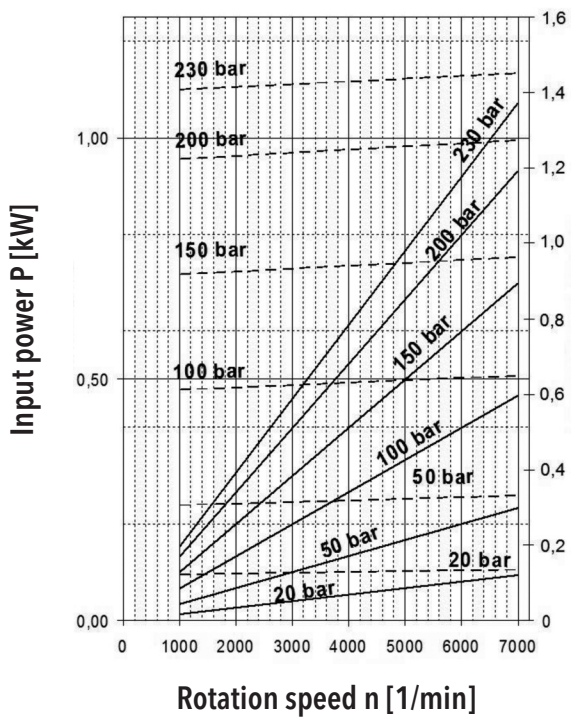

0,40 cm³

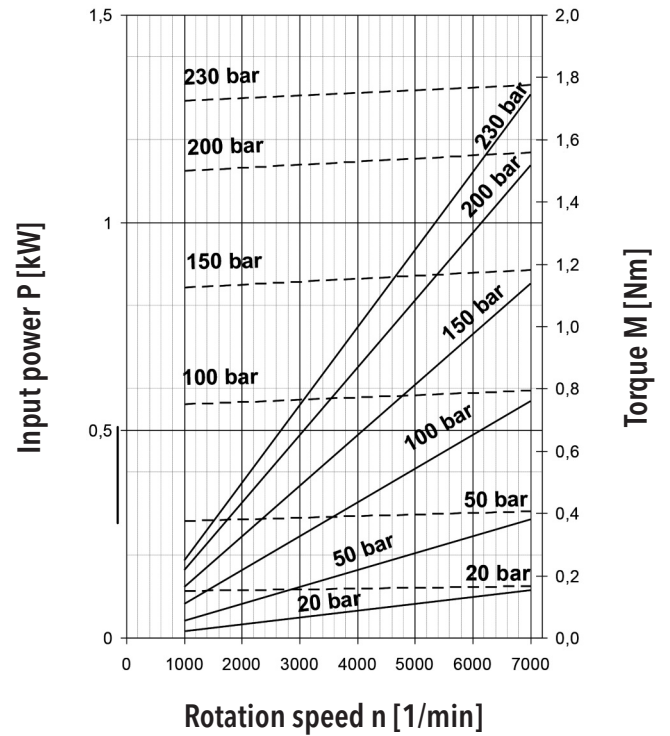

0,50 cm³

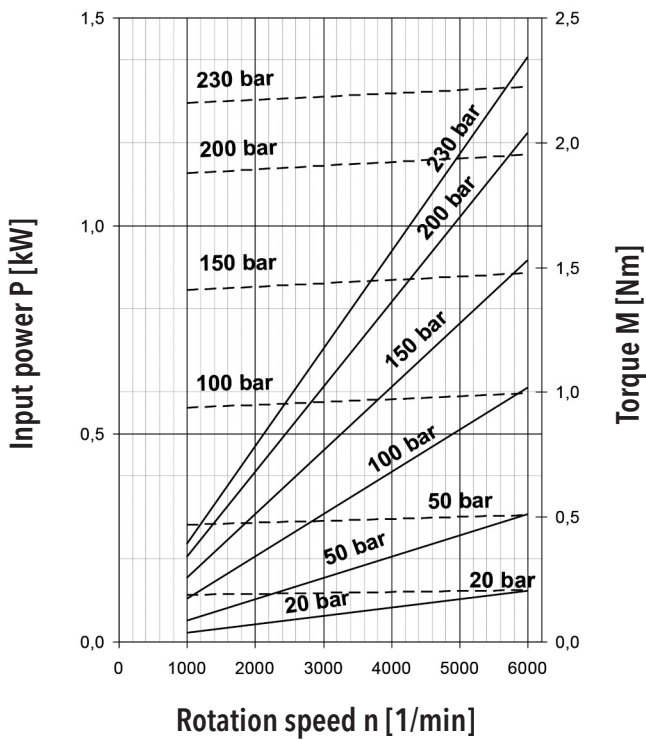

0,63 cm³

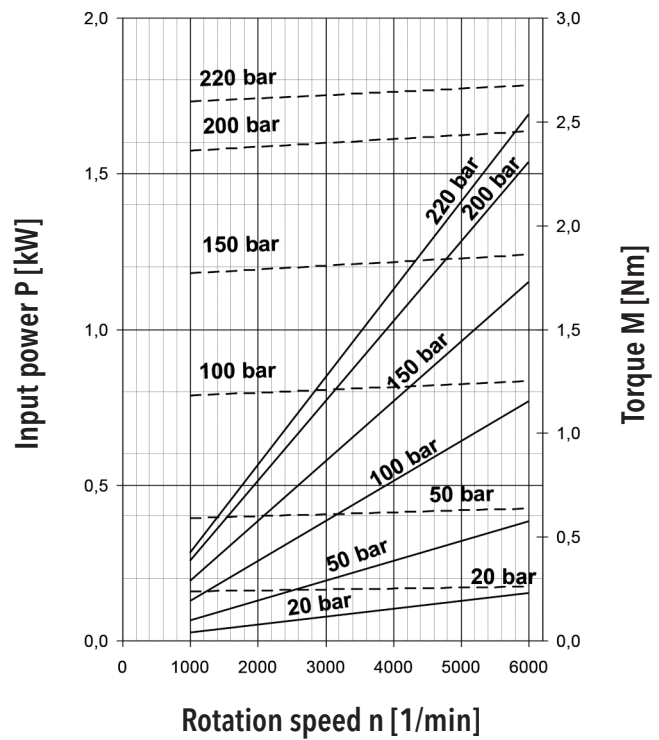

0,70 cm³

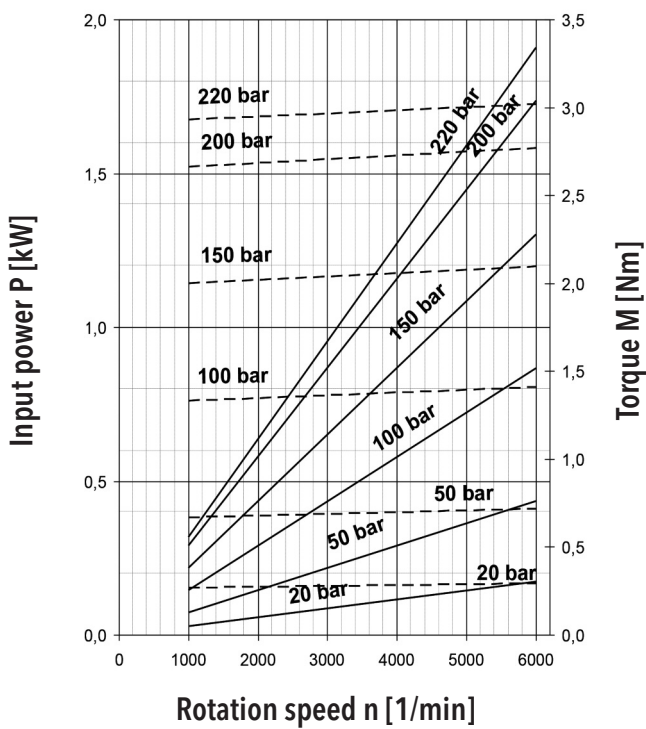

0,80 cm³

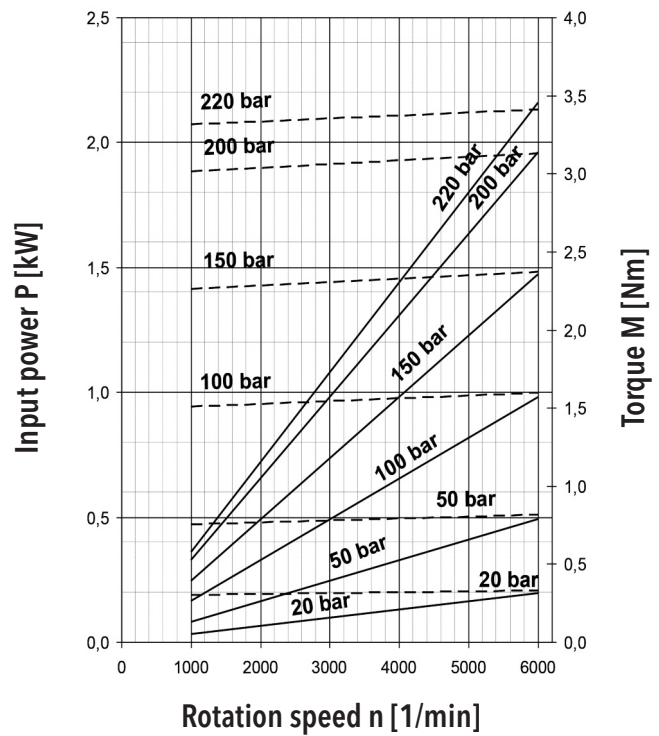

1,00 cm³

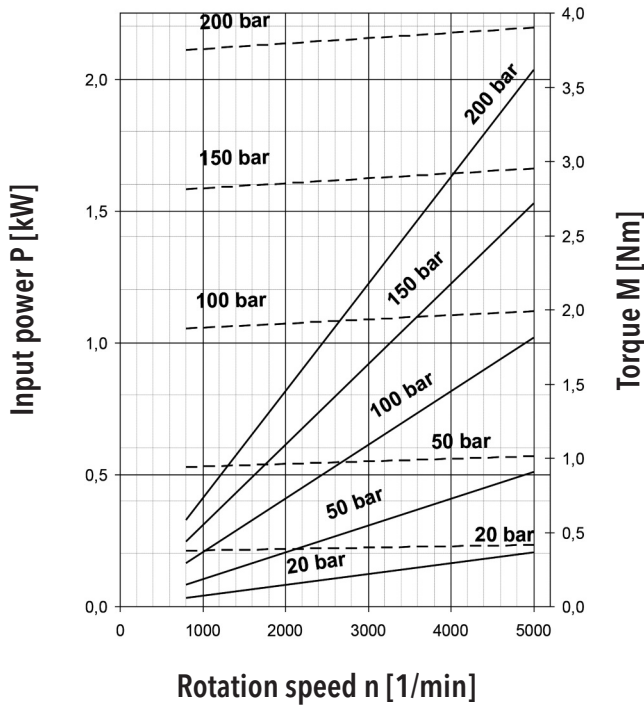

1,25 cm³

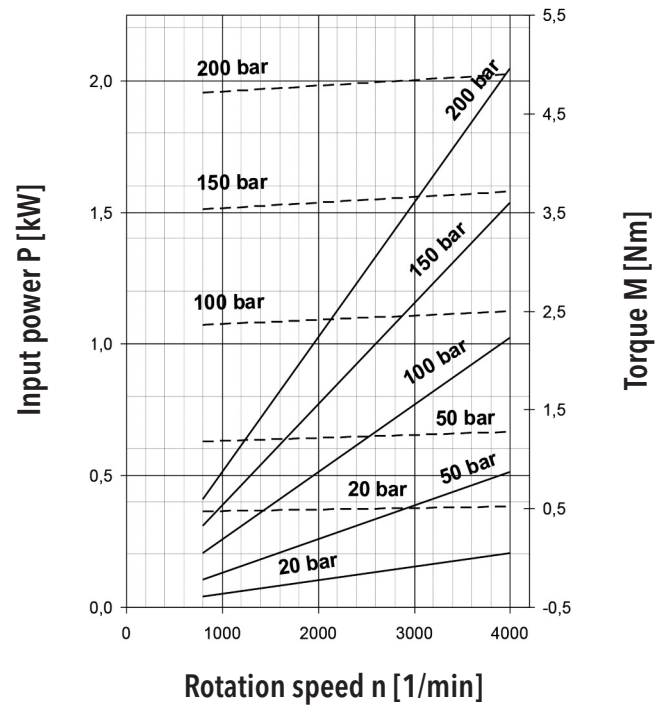

1,50 cm³

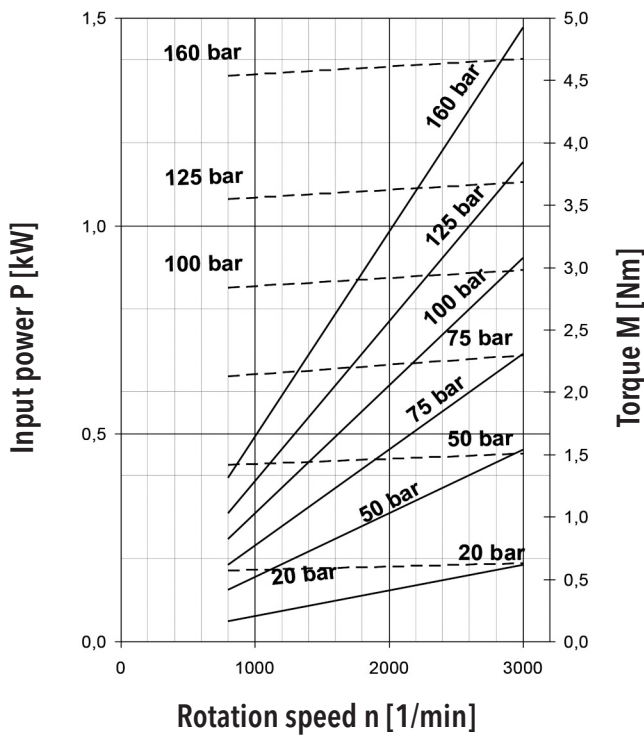

2,00 cm³

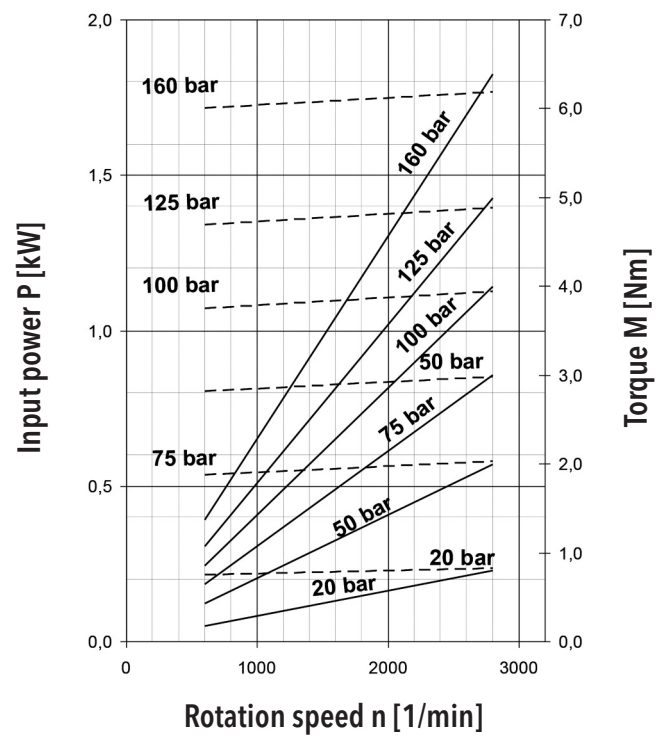

2,50 cm³

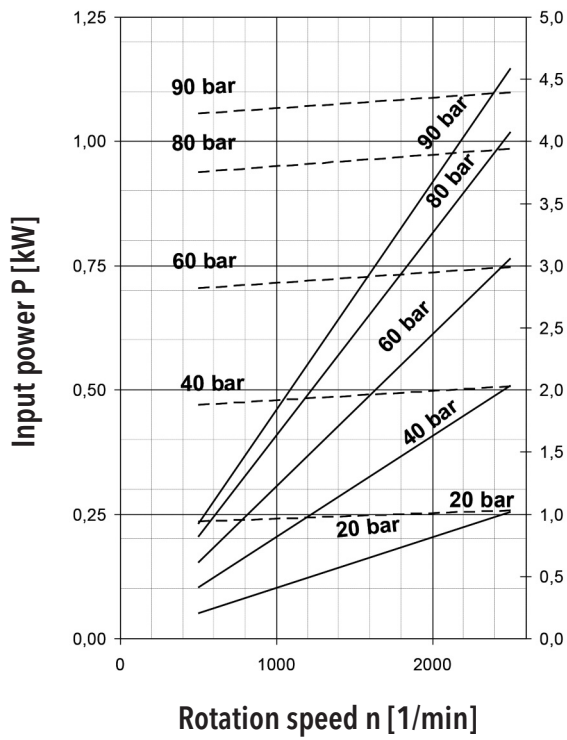

3,20 cm³

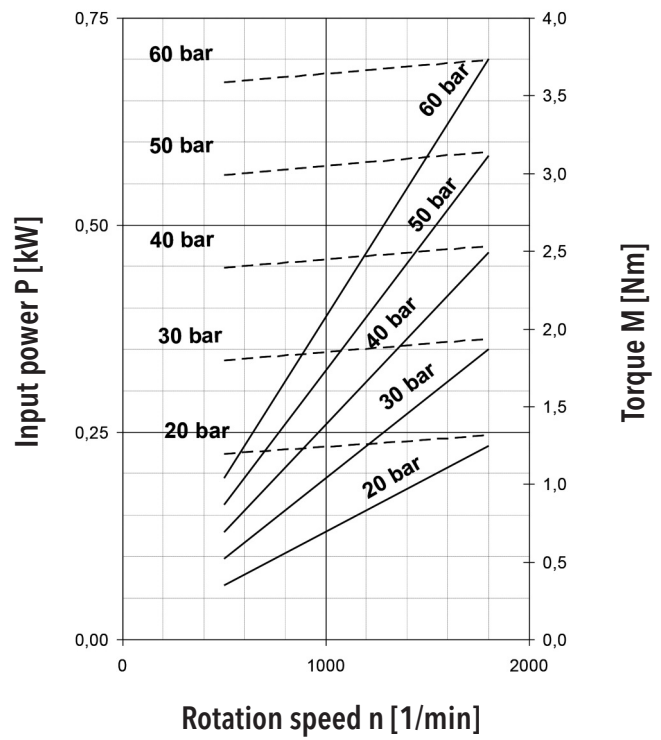

ORDER KEY

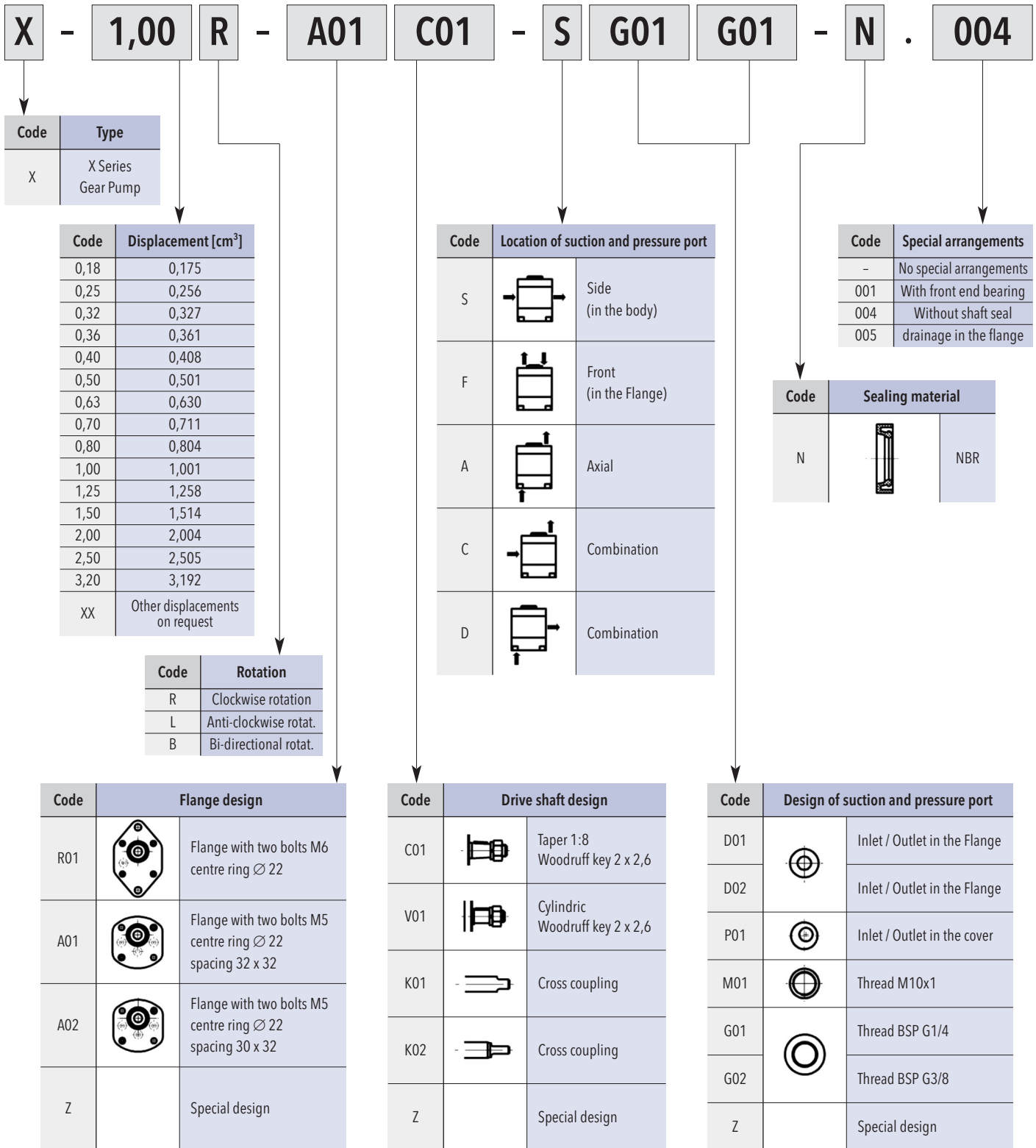

An example of designation for the X clockwise pump with displacement 1.00 cm³, flange with two bolt about spacing 32x32, taper 1:8 with key 2x26, BSP inlet and outlet in body and without shaft sealing:

X-1,00R-A1C1-SG01/G01-N . 004

COMBINATIONS OF FLANGES AND SHAFTS

		FLANGE DESIGN		
		R01	A01	A02
DRIVE SHAFT	C01		●	●
	V01		●	●
	K01		●	●
	K02		●	●

FLANGE DESIGN

R01:

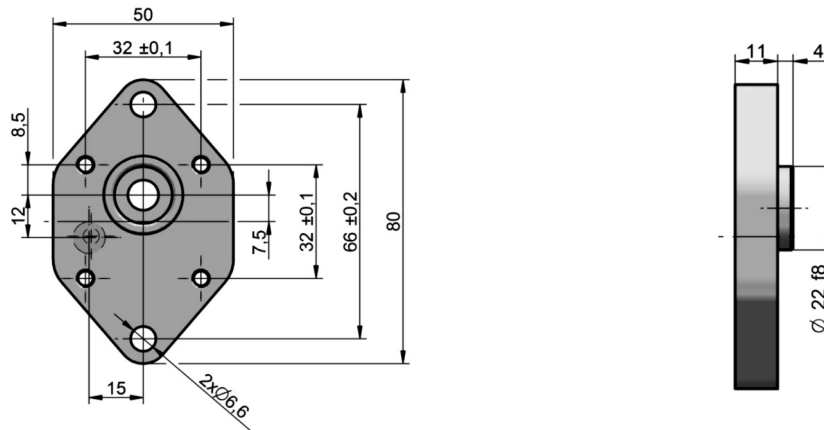

A01:

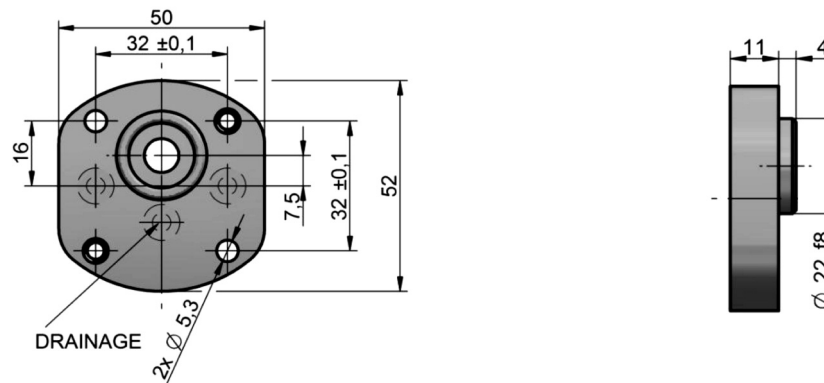

A02:

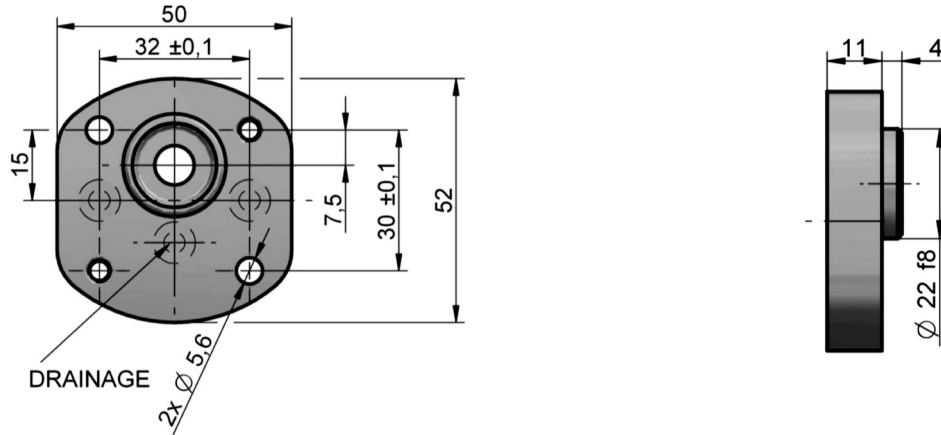

DRIVE SHAFTS

C01:

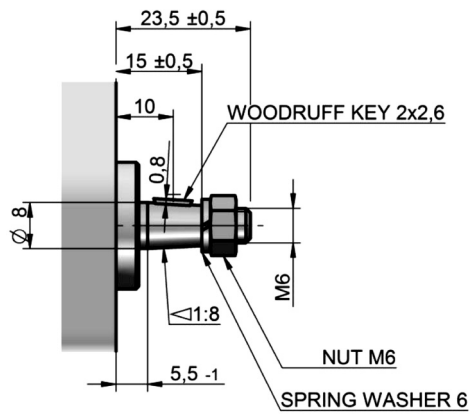

V01:

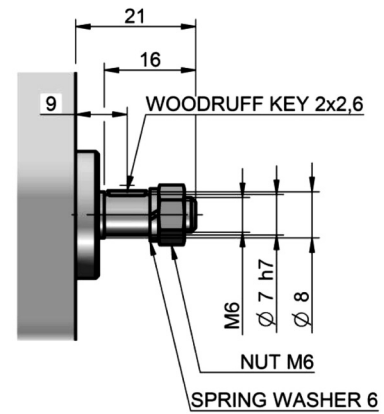

K01:

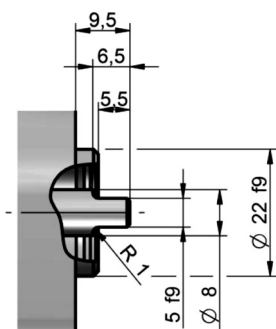

K02:

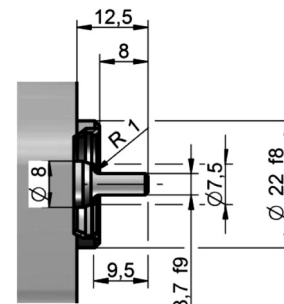

LIQUID INLET AND OUTLET CONNECTION

Metric thread according to ISO 6149

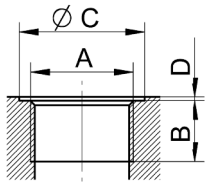

Displacement [cm ³]	Code	Inlet				Code	Outlet				
		A	B	C	D		A	B	C	D	
0.18-0.50	M01	M 10x1	8	15	1	M01	M 10x1	8	15	1	
0.50-3.20		Other types of inputs									

BSPP pipe thread ISO 228-1

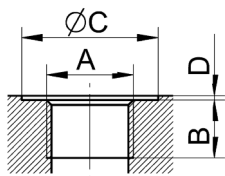

Displacement [cm ³]	Code	Inlet				Code	Outlet			
		A	B	C	D		A	B	C	D
all	G01	G 1/4	13	26	1	G01	G 1/4	13	26	1
	G02	G 3/8	13	24	1	G02	G 3/8	13	24	1

Inlet / outlet in the flange

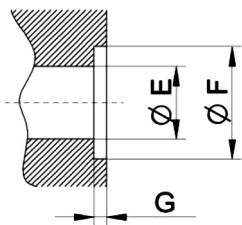

Displacement [cm ³]	Code	Inlet			Code	Outlet		
		E	F	G		E	F	G
all	D01	4.5	8.9	1.1	D01	4.5	8.9	1.1
	D02	4.5	9.5	1.3	D02	4.5	9.5	1.3

Inlet / outlet in the flange

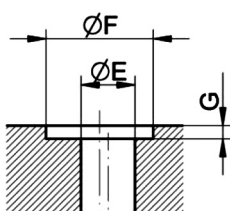

Displacement [cm ³]	Code	Inlet			Code	Outlet		
		E	F	G		E	F	G
all	P01	4.5	8.9	1.1	P01	4.5	8.9	1.1

Drain

Displacement [cm ³]	Code	Inlet			Code	Outlet			
		E	F	G		E	F	G	
all	D01	4.5	8.9	1.1	M01	M 10x1	8	15	1

CATALOGUE SHETS OF X SERIES BASIC DESIGNS

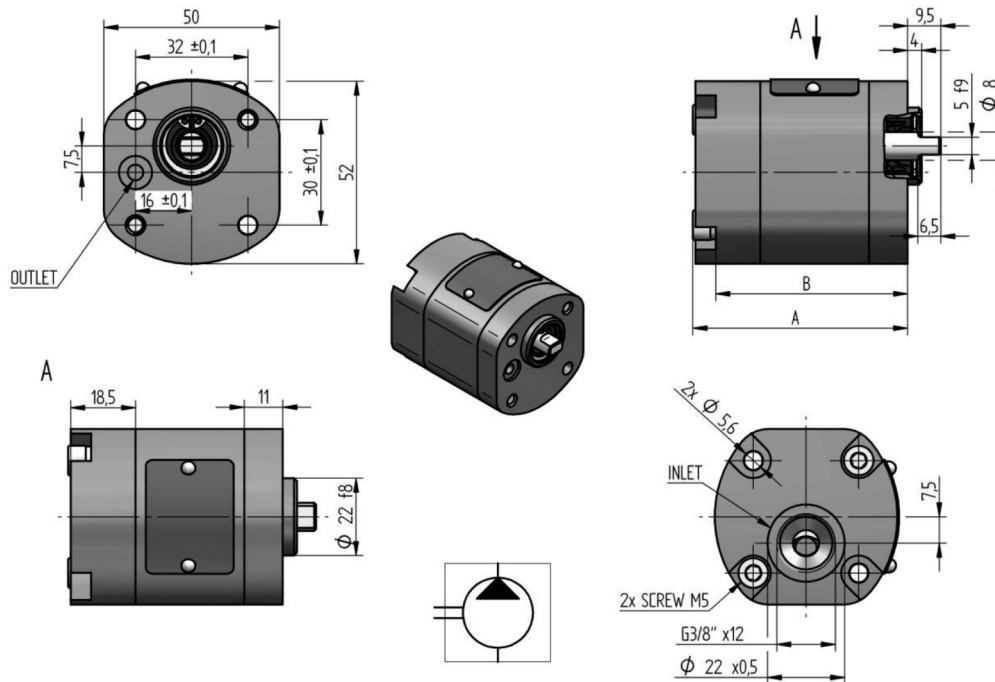

Order key	purch. code	direct. of rot.	displacement [cm ³ /1]	nom. press. [bar]	speed MIN. [min ⁻¹]	speed MAX. [min ⁻¹]	dimension	
							A [mm]	B [mm]
X-3,20R- A02K01-AG02D02-N		R	3,20	60	500	1 800	85,0	79,2
X-3,20L- A02K01-AG02D02-N		L						
X-2,50R- A02K01-AG02D02-N		R	2,50	90	500	2 500	79,1	73,3
X-2,50L- A02K01-AG02D02-N		L						
X-2,00R- A02K01-AG02D02-N		R	2,00	120	600	2 800	74,8	69,0
X-2,00L- A02K01-AG02D02-N		L						
X-1,50R- A02K01-AG02D02-N		R	1,50	160	800	3 000	70,6	64,8
X-1,50L- A02K01-AG02D02-N		L						
X-1,25R- A02K01-AG02D02-N		R	1,25	200	800	4 000	68,4	62,6
X-1,25L- A02K01-AG02D02-N		L						
X-1,00R- A02K01-AG02D02-N		R	1,00	200	800	5 000	66,2	60,4
X-1,00L- A02K01-AG02D02-N		L						
X-0,80R- A02K01-AG02D02-N		R	0,80	220	1 000	6 000	64,5	58,7
X-0,80L- A02K01-AG02D02-N	180 9946	L						
X-0,70R- A02K01-AG02D02-N		R	0,70	220	1 000	6 000	63,7	57,9
X-0,70L- A02K01-AG02D02-N		L						
X-0,63R- A02K01-AG02D02-N		R	0,63	220	1 000	6 000	63,0	57,2
X-0,63L- A02K01-AG02D02-N		L						
X-0,50R- A02K01-AG02D02-N		R	0,50	230	1 000	6 000	61,9	56,1
X-0,50L- A02K01-AG02D02-N	180 9947	L						
X-0,40R- A02K01-AG02D02-N		R	0,40	230	1 000	7 000	61,1	55,3
X-0,40L- A02K01-AG02D02-N		L						
X-0,36R- A02K01-AG02D02-N		R	0,36	230	1 000	7 000	60,7	54,9
X-0,36L- A02K01-AG02D02-N		L						
X-0,32R- A02K01-AG02D02-N		R	0,32	230	1 000	7 000	60,4	54,6
X-0,32L- A02K01-AG02D02-N	180 9954	L						
X-0,25R- A02K01-AG02D02-N		R	0,25	230	1 000	7 000	59,8	54,0
X-0,25L- A02K01-AG02D02-N	180 9956	L						
X-0,18R- A02K01-AG02D02-N		R	0,18	200	1 000	8 000	59,1	53,3
X-0,18L- A02K01-AG02D02-N	180 9953	L						

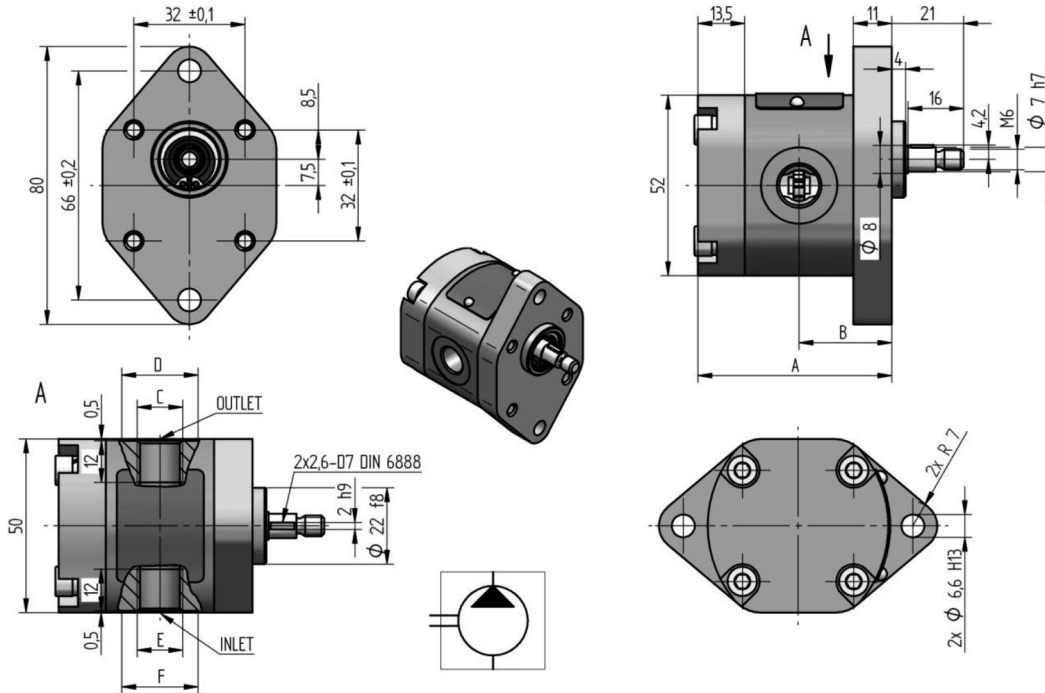

Order key	purch. code	direct. of rot.	displacement [cm ³ /1]	nom. press. [bar]	speed MIN. [min ⁻¹]	speed MAX. [min ⁻¹]	dimension					
							A [mm]	B [mm]	C [mm]	D [mm]	E [mm]	F [mm]
X-3,20R- R01V01-SG01G01-N		R	3,20	60	500	1 800	80,0	38,8	G 1/4	Ø 22	G 1/4	Ø 22
X-3,20L- R01V01-SG01G01-N		L										
X-2,50R- R01V01-SG01G01-N		R	2,50	90	500	2 500	74,1	35,8	G 1/4	Ø 22	G 1/4	Ø 22
X-2,50L- R01V01-SG01G01-N		L										
X-2,00R- R01V01-SG01G01-N		R	2,00	120	600	2 800	69,8	33,7	G 1/4	Ø 22	G 1/4	Ø 22
X-2,00L- R01V01-SG01G01-N		L										
X-1,50R- R01V01-SG01G01-N		R	1,50	160	800	3 000	65,6	31,6	G 1/4	Ø 22	G 1/4	Ø 22
X-1,50L- R01V01-SG01G01-N		L										
X-1,25R- R01V01-SG01G01-N	180 9952	R	1,25	200	800	4 000	63,4	30,5	G 1/4	Ø 22	G 1/4	Ø 22
X-1,25L- R01V01-SG01G01-N	180 9961	L										
X-1,00R- R01V01-SG01G01-N		R	1,00	200	800	5 000	61,2	29,4	G 1/4	Ø 22	G 1/4	Ø 22
X-1,00L- R01V01-SG01G01-N		L										
X-0,80R- R01V01-SG01G01-N	180 9951	R	0,80	220	1 000	6 000	59,5	28,5	G 1/4	Ø 22	G 1/4	Ø 22
X-0,80L- R01V01-SG01G01-N	180 9960	L										
X-0,70R- R01V01-SG01G01-N		R	0,70	220	1 000	6 000	58,7	28,1	G 1/4	Ø 22	G 1/4	Ø 22
X-0,70L- R01V01-SG01G01-N		L										
X-0,63R- R01V01-SG01G01-N		R	0,63	220	1 000	6 000	58,0	27,8	G 1/4	Ø 22	G 1/4	Ø 22
X-0,63L- R01V01-SG01G01-N		L										
X-0,50R- R01V01-SG01G01-N		R	0,50	230	1 000	6 000	56,9	27,2	G 1/4	Ø 22	G 1/4	Ø 22
X-0,50L- R01V01-SG01G01-N		L										
X-0,40R- R01V01-SG01G01-N		R	0,40	230	1 000	7 000	56,1	26,8	G 1/4	Ø 22	G 1/4	Ø 22
X-0,40L- R01V01-SG01G01-N		L										
X-0,36R- R01V01-SG01G01-N		R	0,36	230	1 000	7 000	55,7	26,6	G 1/4	Ø 22	G 1/4	Ø 22
X-0,36L- R01V01-SG01G01-N		L										
X-0,32R- R01V01-SG01G01-N		R	0,32	230	1 000	7 000	55,4	26,5	G 1/4	Ø 22	G 1/4	Ø 22
X-0,32L- R01V01-SG01G01-N	180 9964	L										
X-0,25R- R01V01-SG01G01-N		R	0,25	230	1 000	7 000	54,8	26,2	G 1/4	Ø 22	G 1/4	Ø 22
X-0,25L- R01V01-SG01G01-N	180 9963	L										
X-0,18R- R01V01-SG01G01-N		R	0,18	200	1 000	8 000	54,1	25,8	G 1/4	Ø 22	G 1/4	Ø 22
X-0,18L- R01V01-SG01G01-N		L										

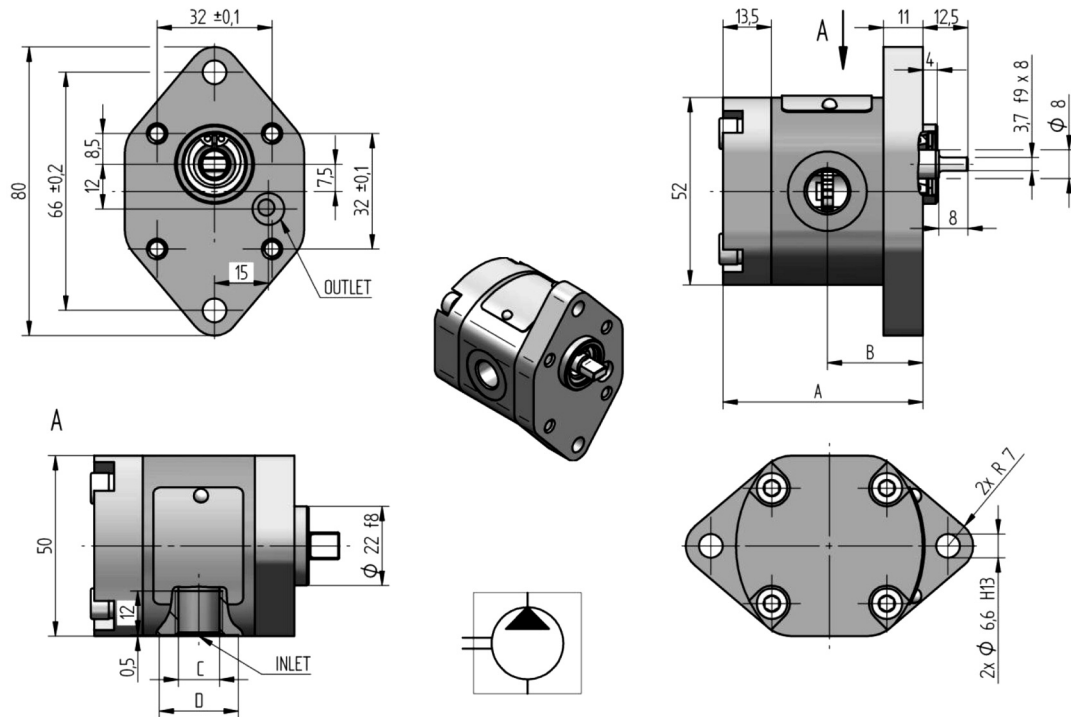

Order key	purch. code	direct. of rot.	displacement [cm ³ /1]	nom. press. [bar]	speed MIN. [min ⁻¹]	speed MAX. [min ⁻¹]	dimension			
							A [mm]	B [mm]	C [mm]	D [mm]
X-3,20R- R01K02-CG01P01-N		R	3,20	60	500	1 800	80,0	38,8	G 1/4	Ø 22
X-3,20L- R01K02-CG01P01-N		L								
X-2,50R- R01K02-CG01P01-N		R	2,50	90	500	2 500	74,1	35,8	G 1/4	Ø 22
X-2,50L- R01K02-CG01P01-N		L								
X-2,00R- R01K02-CG01P01-N		R	2,00	120	600	2 800	69,8	33,7	G 1/4	Ø 22
X-2,00L- R01K02-CG01P01-N		L								
X-1,50R- R01K02-CG01P01-N		R	1,50	160	800	3 000	65,6	31,6	G 1/4	Ø 22
X-1,50L- R01K02-CG01P01-N		L								
X-1,25R- R01K02-CG01P01-N		R	1,25	200	800	4 000	63,4	30,5	G 1/4	Ø 22
X-1,25L- R01K02-CG01P01-N		L								
X-1,00R- R01K02-CG01P01-N		R	1,00	200	800	5 000	61,2	29,4	G 1/4	Ø 22
X-1,00L- R01K02-CG01P01-N		L								
X-0,80R- R01K02-CG01P01-N	180 9950	R	0,80	220	1 000	6 000	59,5	28,5	G 1/4	Ø 22
X-0,80L- R01K02-CG01P01-N		L								
X-0,70R- R01K02-CG01P01-N		R	0,70	220	1 000	6 000	58,7	28,1	G 1/4	Ø 22
X-0,70L- R01K02-CG01P01-N		L								
X-0,63R- R01K02-CG01P01-N		R	0,63	220	1 000	6 000	58,0	27,8	G 1/4	Ø 22
X-0,63L- R01K02-CG01P01-N		L								
X-0,50R- R01K02-CG01P01-N		R	0,50	230	1 000	6 000	56,9	27,2	G 1/4	Ø 22
X-0,50L- R01K02-CG01P01-N		L								
X-0,40R- R01K02-CG01P01-N		R	0,40	230	1 000	7 000	56,1	26,8	G 1/4	Ø 22
X-0,40L- R01K02-CG01P01-N		L								
X-0,36R- R01K02-CG01P01-N		R	0,36	230	1 000	7 000	55,7	26,6	G 1/4	Ø 22
X-0,36L- R01K02-CG01P01-N		L								
X-0,32R- R01K02-CG01P01-N	180 9949	R	0,32	230	1 000	7 000	55,4	26,5	G 1/4	Ø 22
X-0,32L- R01K02-CG01P01-N		L								
X-0,25R- R01K02-CG01P01-N		R	0,25	230	1 000	7 000	54,8	26,2	G 1/4	Ø 22
X-0,25L- R01K02-CG01P01-N		L								
X-0,18R- R01K02-CG01P01-N		R	0,18	200	1 000	8 000	54,1	25,8	G 1/4	Ø 22
X-0,18L- R01K02-CG01P01-N		L								

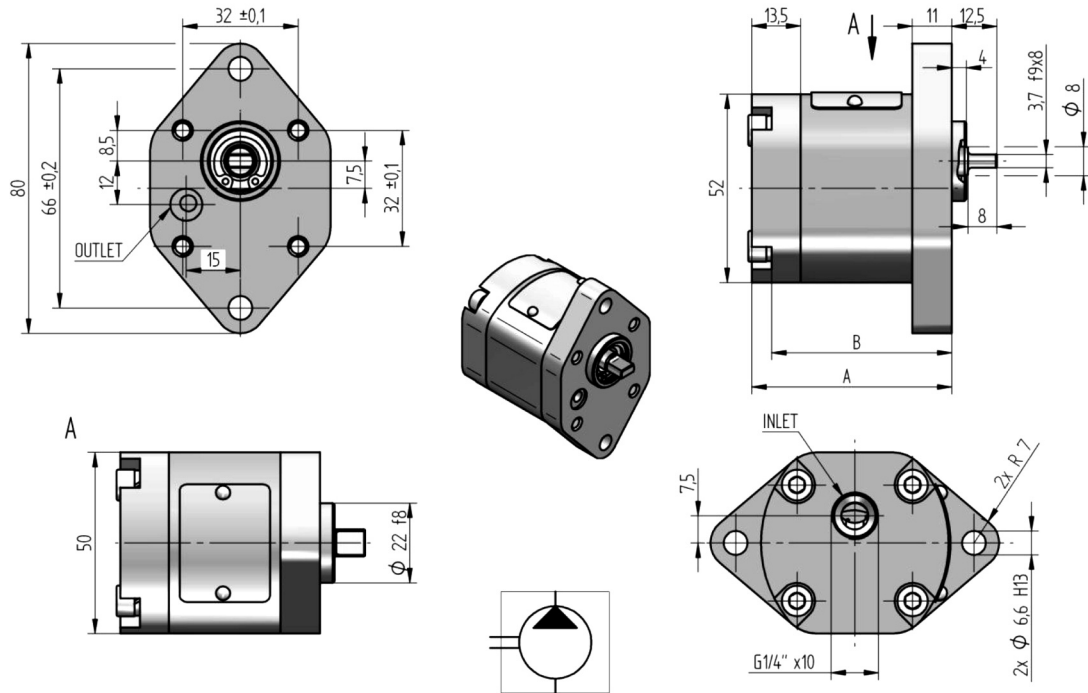

Order key	purch. code	direct. of rot.	displacement [cm ³ /1]	nom. press. [bar]	speed MIN. [min ⁻¹]	speed MAX. [min ⁻¹]	dimension	
							A [mm]	B [mm]
X-3,20R- R01K02-AG01P01-N		R	3,20	60	500	1 800	80,0	74,5
X-3,20L- R01K02-AG01P01-N		L						
X-2,50R- R01K02-AG01P01-N		R	2,50	90	500	2 500	74,1	68,6
X-2,50L- R01K02-AG01P01-N		L						
X-2,00R- R01K02-AG01P01-N		R	2,00	120	600	2 800	69,8	64,3
X-2,00L- R01K02-AG01P01-N		L						
X-1,50R- R01K02-AG01P01-N		R	1,50	160	800	3 000	65,6	60,1
X-1,50L- R01K02-AG01P01-N	180 9793	L						
X-1,25R- R01K02-AG01P01-N	180 9910	R	1,25	200	800	4 000	63,4	57,9
X-1,25L- R01K02-AG01P01-N	180 9798	L						
X-1,00R- R01K02-AG01P01-N		R	1,00	200	800	5 000	61,2	55,7
X-1,00L- R01K02-AG01P01-N	180 9794	L						
X-0,80R- R01K02-AG01P01-N	180 9909	R	0,80	220	1 000	6 000	59,5	54,0
X-0,80L- R01K02-AG01P01-N	180 9797	L						
X-0,70R- R01K02-AG01P01-N		R	0,70	220	1 000	6 000	58,7	53,2
X-0,70L- R01K02-AG01P01-N		L						
X-0,63R- R01K02-AG01P01-N		R	0,63	220	1 000	6 000	58,0	52,5
X-0,63L- R01K02-AG01P01-N	180 9799	L						
X-0,50R- R01K02-AG01P01-N		R	0,50	230	1 000	6 000	56,9	51,4
X-0,50L- R01K02-AG01P01-N	180 9796	L						
X-0,40R- R01K02-AG01P01-N		R	0,40	230	1 000	7 000	56,1	50,6
X-0,40L- R01K02-AG01P01-N	180 9795	L						
X-0,36R- R01K02-AG01P01-N		R	0,36	230	1 000	7 000	55,7	50,2
X-0,36L- R01K02-AG01P01-N		L						
X-0,32R- R01K02-AG01P01-N		R	0,32	230	1 000	7 000	55,4	49,9
X-0,32L- R01K02-AG01P01-N	180 9792	L						
X-0,25R- R01K02-AG01P01-N		R	0,25	230	1 000	7 000	54,8	49,3
X-0,25L- R01K02-AG01P01-N		L						
X-0,18R- R01K02-AG01P01-N		R	0,18	200	1 000	8 000	54,1	48,6
X-0,18L- R01K02-AG01P01-N		L						

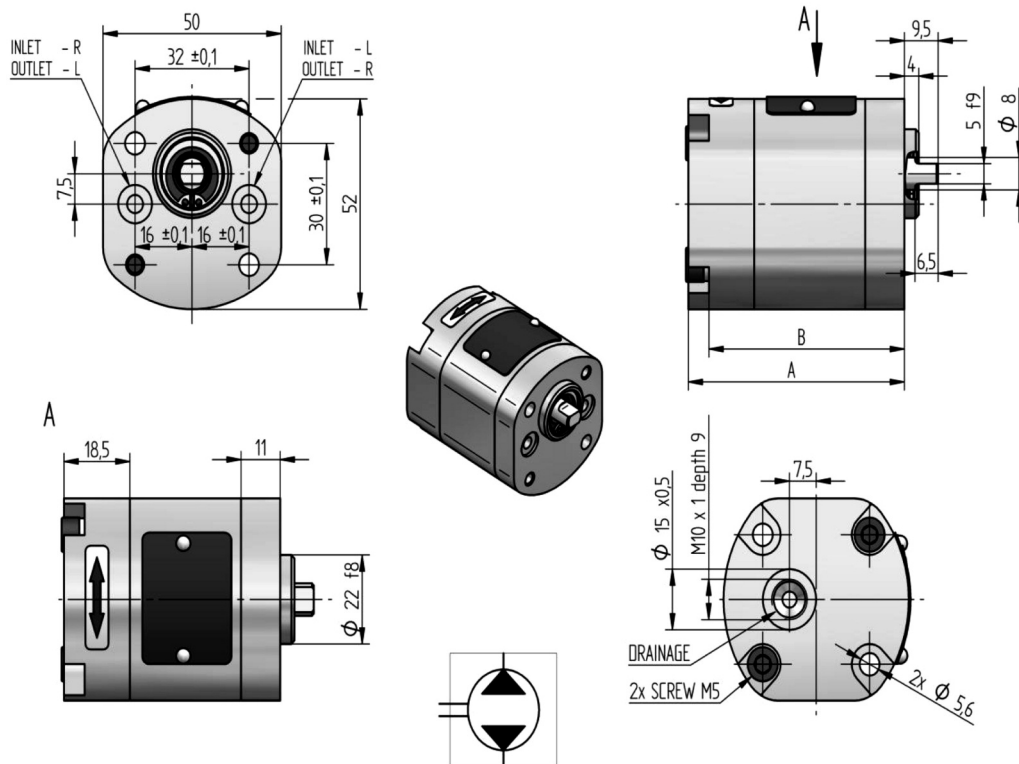

Order key	purch. code	direct. of rot.	displacement [cm ³ /1]	nom. press. [bar]	speed MIN. [min ⁻¹]	speed MAX. [min ⁻¹]	dimension	
							A [mm]	B [mm]
X-3,20B-A02K01-FD02D02-N		B	3,20	60	500	1 800	85,0	79,2
X-2,50B-A02K01-FD02D02-N		B	2,50	90	500	2 500	79,1	73,3
X-2,00B-A02K01-FD02D02-N		B	2,00	120	600	2 800	74,8	69,0
X-1,50B-A02K01-FD02D02-N		B	1,50	160	800	3 000	70,6	64,8
X-1,25B-A02K01-FD02D02-N		B	1,25	200	800	4 000	68,4	62,6
X-1,00B-A02K01-FD02D02-N		B	1,00	200	800	5 000	66,2	60,4
X-0,80B-A02K01-FD02D02-N		B	0,80	220	1 000	6 000	64,5	58,7
X-0,70B-A02K01-FD02D02-N		B	0,70	220	1 000	6 000	63,7	57,9
X-0,63B-A02K01-FD02D02-N		B	0,63	220	1 000	6 000	63,0	57,2
X-0,50B-A02K01-FD02D02-N		B	0,50	230	1 000	6 000	61,9	56,1
X-0,40B-A02K01-FD02D02-N		B	0,40	230	1 000	7 000	61,1	55,3
X-0,36B-A02K01-FD02D02-N		B	0,36	230	1 000	7 000	60,7	54,9
X-0,32B-A02K01-FD02D02-N		B	0,32	230	1 000	7 000	60,4	54,6
X-0,25B-A02K01-FD02D02-N		B	0,25	230	1 000	7 000	59,8	54
X-0,18B-A02K01-FD02D02-N	180 9944	B	0,18	200	1 000	8 000	59,1	53,3

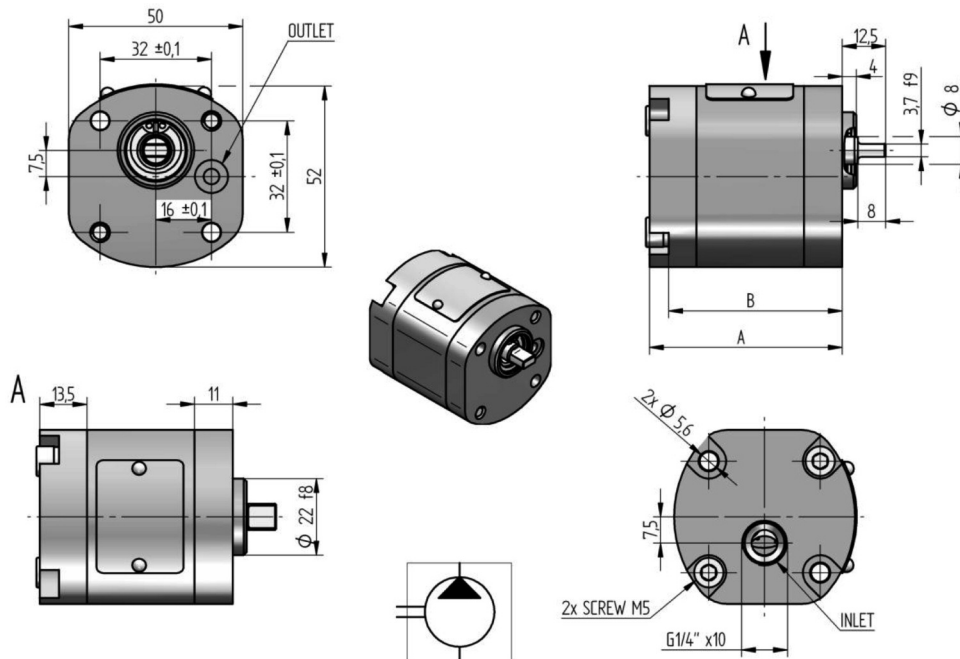

Order key	purch. code	direct. of rot.	displacement [cm ³ /1]	nom. press. [bar]	speed MIN. [min ⁻¹]	speed MAX. [min ⁻¹]	dimension	
							A [mm]	B [mm]
X-3,20R- A01K02-AG01D01-N		R	3,20	60	500	1 800	80,0	74,5
X-3,20L- A01K02-AG01D01-N		L						
X-2,50R- A01K02-AG01D01-N		R	2,50	90	500	2 500	74,1	68,6
X-2,50L- A01K02-AG01D01-N		L						
X-2,00R- A01K02-AG01D01-N		R	2,00	120	600	2 800	69,8	64,3
X-2,00L- A01K02-AG01D01-N		L						
X-1,50R- A01K02-AG01D01-N	180 9875	R	1,50	160	800	3 000	65,6	60,1
X-1,50L- A01K02-AG01D01-N	180 9807	L						
X-1,25R- A01K02-AG01D01-N	180 9902	R	1,25	200	800	4 000	63,4	57,9
X-1,25L- A01K02-AG01D01-N	180 9806	L						
X-1,00R- A01K02-AG01D01-N	180 9874	R	1,00	200	800	5 000	61,2	55,7
X-1,00L- A01K02-AG01D01-N	180 9805	L						
X-0,80R- A01K02-AG01D01-N	180 9867	R	0,80	220	1 000	6 000	59,5	54,0
X-0,80L- A01K02-AG01D01-N	180 9804	L						
X-0,70R- A01K02-AG01D01-N		R	0,70	220	1 000	6 000	58,7	53,2
X-0,70L- A01K02-AG01D01-N		L						
X-0,63R- A01K02-AG01D01-N		R	0,63	220	1 000	6 000	58,0	52,5
X-0,63L- A01K02-AG01D01-N	180 9803	L						
X-0,50R- A01K02-AG01D01-N	180 9873	R	0,50	230	1 000	6 000	56,9	51,4
X-0,50L- A01K02-AG01D01-N	180 9802	L						
X-0,40R- A01K02-AG01D01-N		R	0,40	230	1 000	7 000	56,1	50,6
X-0,40L- A01K02-AG01D01-N	180 9801	L						
X-0,36R- A01K02-AG01D01-N		R	0,36	230	1 000	7 000	55,7	50,2
X-0,36L- A01K02-AG01D01-N		L						
X-0,32R- A01K02-AG01D01-N	180 9872	R	0,32	230	1 000	7 000	55,4	49,9
X-0,32L- A01K02-AG01D01-N	180 9800	L						
X-0,25R- A01K02-AG01D01-N		R	0,25	230	1 000	7 000	54,8	49,3
X-0,25L- A01K02-AG01D01-N		L						
X-0,18R- A01K02-AG01D01-N		R	0,18	200	1 000	8 000	54,1	48,6
X-0,18L- A01K02-AG01D01-N		L						

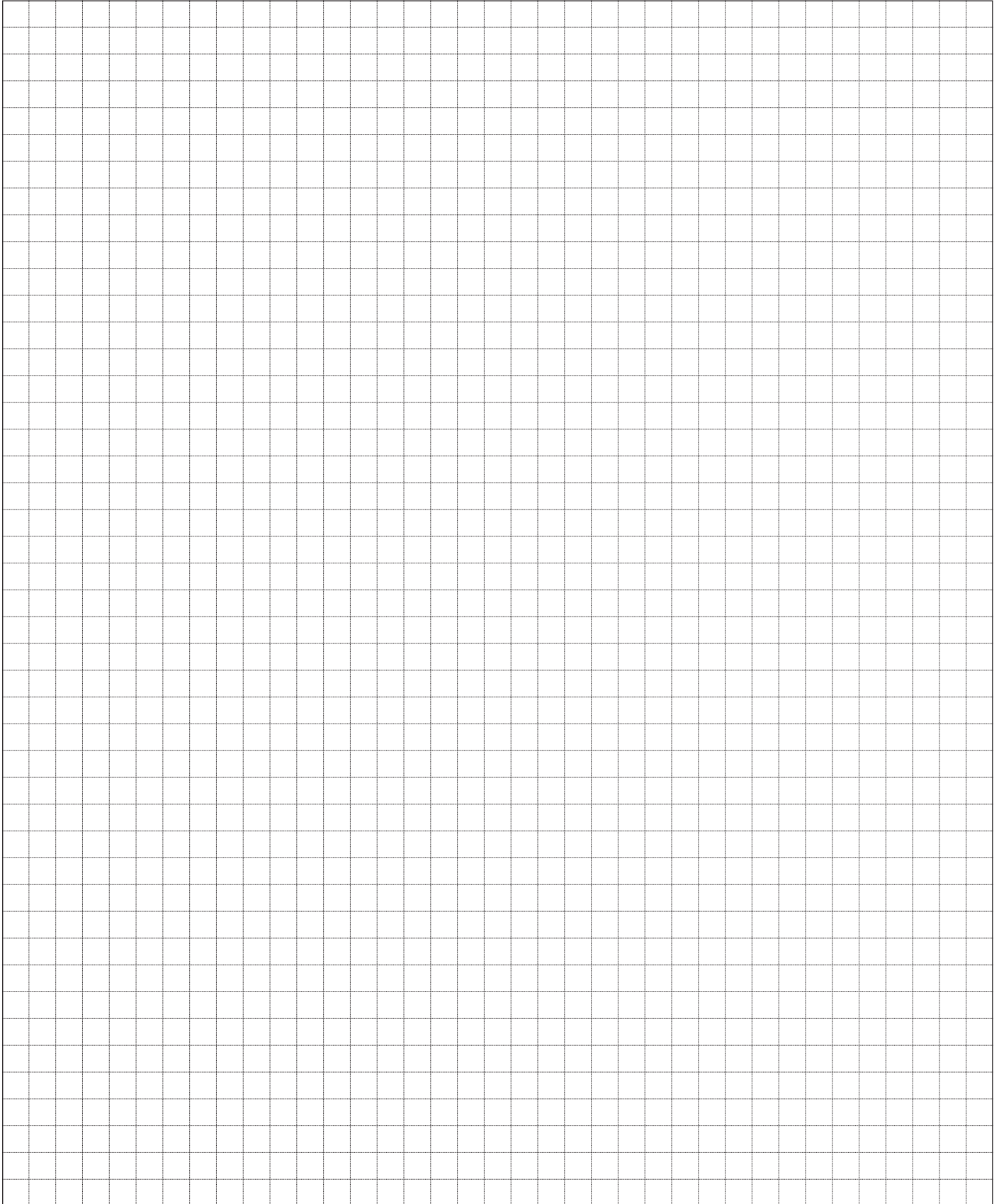

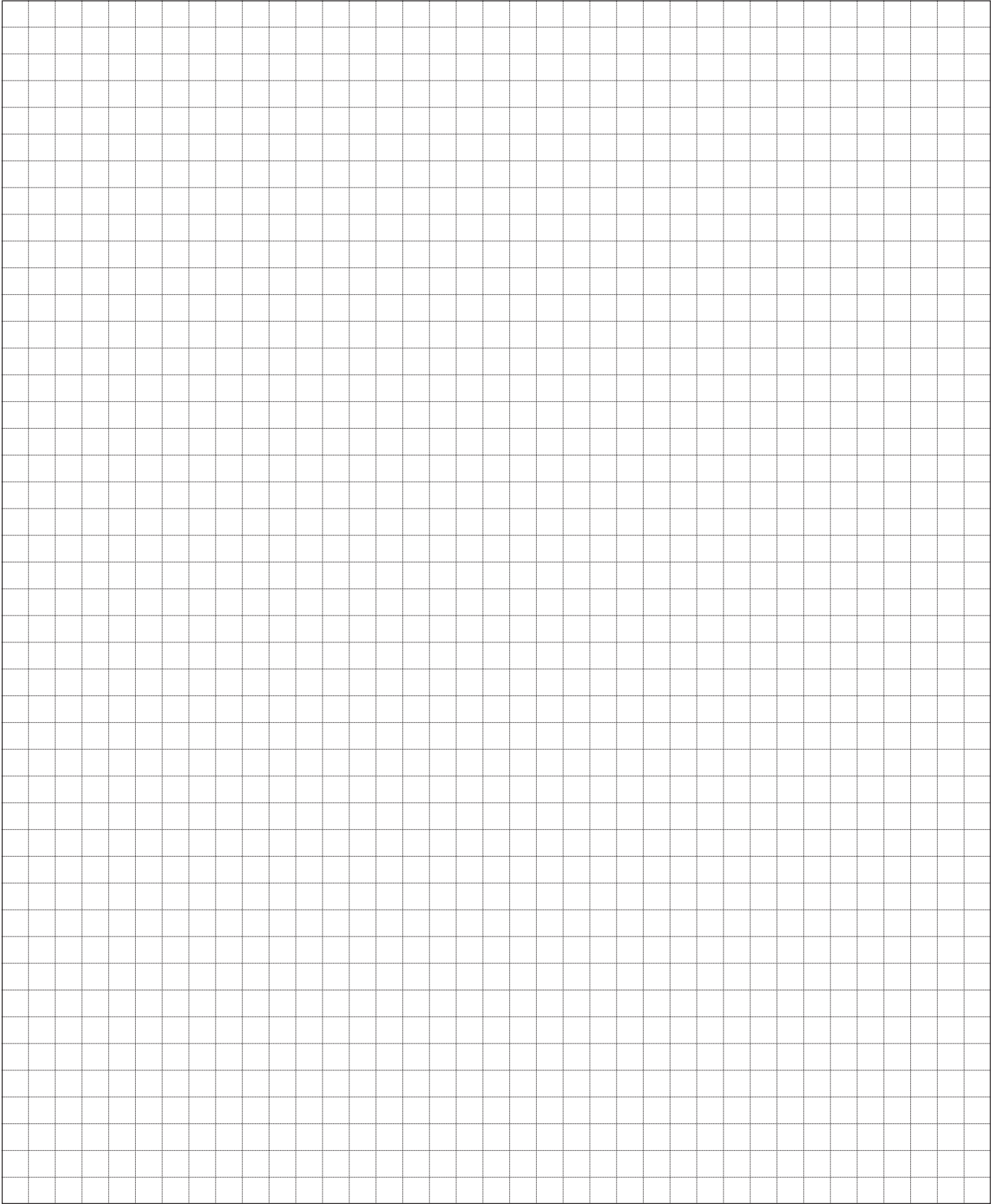

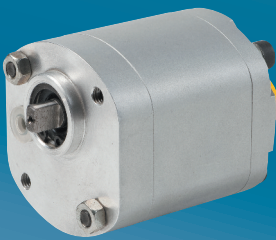
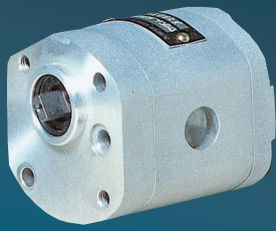

jihostroj
AERO TECHNOLOGY & HYDRAULICS

JIHOSTROJ a.s.
Budějovická 148
CZ 382 32 Velešín
Czech Republic
tel.: +420 380 340 511
fax: +420 380 340 612
e-mail: mailbox@jihostroj.cz
http: //www.jihostroj.com

GPS 48°49'51.748" N 14°27'40.770" E

