

**Displacement** from 5 to 39 ccm  
**Pressure** up to 280 bar  
**Speed** from 400 to 3000 RPM

**GEAR PUMPS**  
**UD**

## TABLE OF CONTENTS

DESCRIPTION.....	2
BASIC PARTS OF PUMP .....	2
PARAMETER TABLE .....	3
FORMULAS USED FOR CALCULATION.....	4
PUMP EFFICIENCIES .....	4
WORKING LIQUID.....	5
PRESSURE LOAD.....	5
DIRECTION OF ROTATION .....	6
OTHER REQUIREMENTS .....	6
ALLOWABLE TORQUE ON THE OUTPUT SHAFT DEPENDENT ON PRESSURE .....	7
REVERSIBLE DESIGN.....	8
PUMP WITH FRONT-END BEARING .....	9
FLOW REGULATOR FOR UNIDIRECTIONAL PUMP.....	9
UD FLOW RATE AND POWER CURVES.....	10
ORDER KEY - SINGLE VERSION .....	13
ORDER KEY - MULTIPLE VERSION.....	14
COMBINATIONS OF FLANGES AND SHAFTS .....	15
FLANGE DESIGN .....	16
DRIVE SHAFTS.....	17
LIQUID INLET AND OUTLET CONNECTION.....	18
CATALOGUE SHETS OF UD SERIES BASIC DESIGNS.....	19
NOTES .....	23

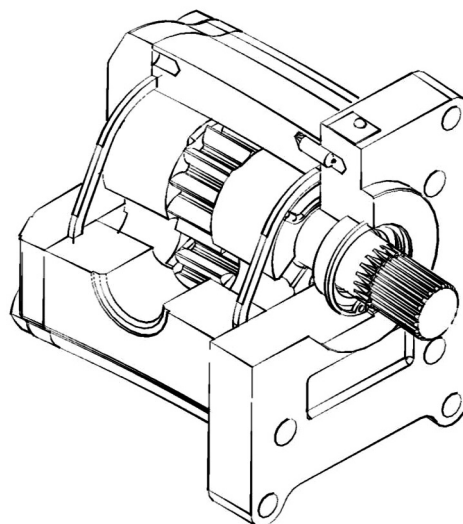

## DESCRIPTION

- UD series pumps based construct and the displacement range of UD series pumps is based on the proven UC (UN) series. The cover and flange are manufactured from grey iron. The body is designed from aluminum alloy shaped profile bars. Pumps are connected with four through-bolts made of M12 high strength steel. They are equipped with a hydraulic pressure compensation axial-clearance which is executed by means of a balancing sealing directly in the bearing sleeves. Compared to the previous design of UC (UN), the UD series pumps have better noise, maximum pressure and flow efficiency within the entire speed range, whereas the favorable price has been maintained. UD series offers a possibility large range displacement  $V_g = 5$  to  $39 \text{ cm}^3/\text{rev}$ , at achieve nominal pressure up to 30 MPa. They are produced in unidirectional and in multiple versions.
- Pumps of UD series can be equipped with flow regulation and a relief valve (see. page 9 - 12), both in the unidirectional and multiple version (see. page 24).

## BASIC PARTS OF PUMP

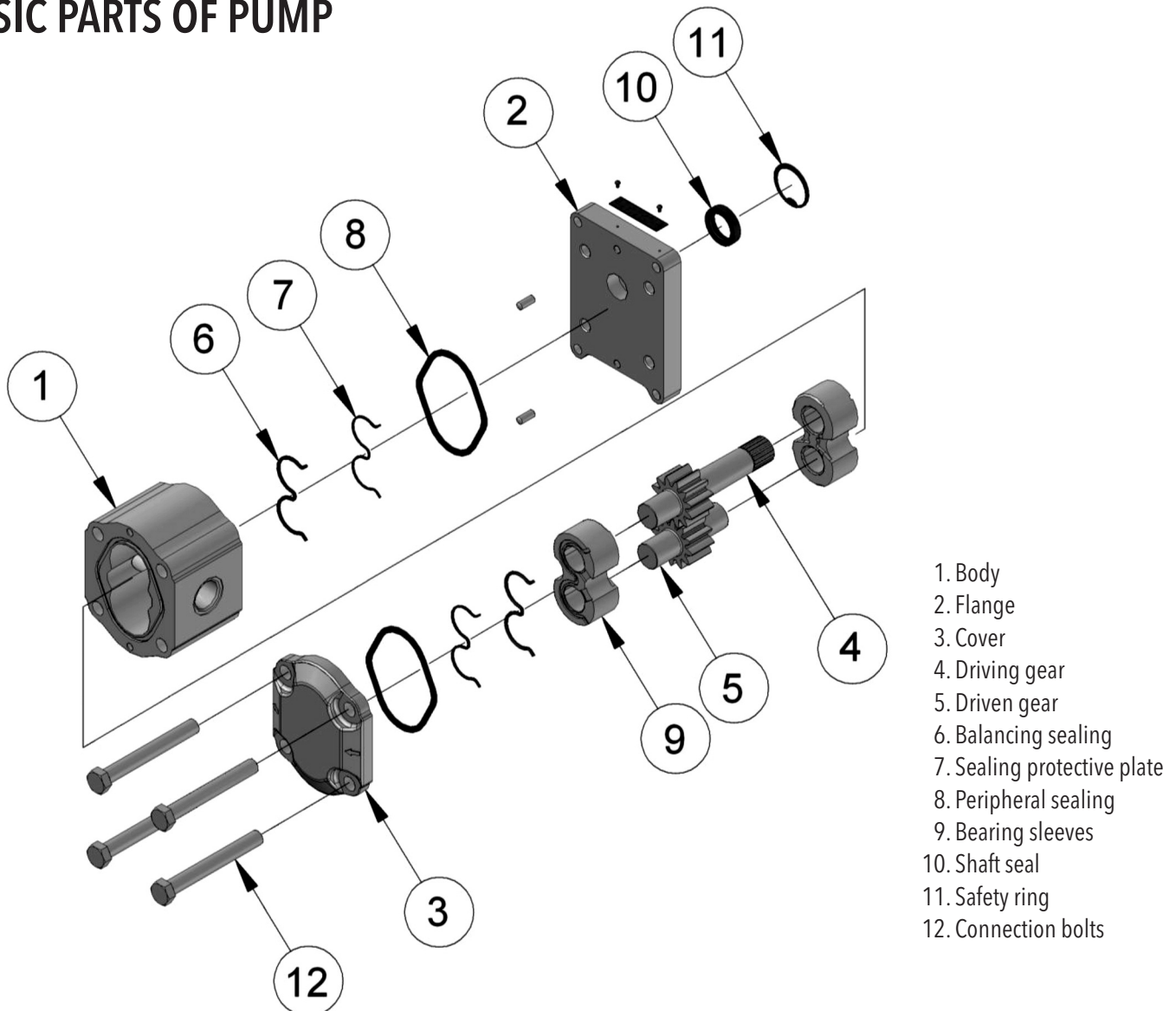

- A reinforced version (UDD), or a shortened version (UDK) can be used for special purposes
- UDD pumps are a reinforced version that is about 10 mm longer. The Pump has increased the pressure from displacement  $>16 \text{ cm}^3/\text{rev}$ . The position of the inlets and outlets is shifted by about 5 mm on body and about 10 mm on the cover compared with the standard version.
- UDK pumps are about 11.4 mm shorter. The position of the inlets and outlets is shifted by about 5.7 mm on body and 11.4 mm on the cover compared with the standard version.

## PARAMETER TABLE

Nominal Size Parameters		Sym.	Unit.	UD 8	UD 10	UD 12,5	UD 16	UD 20	UD 25	UD 28	UD 31
Actual displacement		$V_g$	[cm <sup>3</sup> ]	7.93	10.02	12.10	16.28	20.45	25.46	28.38	32.14
Rotation speed	nominal	$n_n$	[min <sup>-1</sup> ]	1500	1500	1500	1500	1500	1500	1500	1500
	minimum	$n_{min}$	[min <sup>-1</sup> ]	600	450	450	450	450	450	450	450
	maximum	$n_{max}$	[min <sup>-1</sup> ]	3200	3200	3200	3200	3200	3200	3000	2800
Pressure at inlet*	minimum	$p_{1min}$	[bar]	-0.30	-0.30	-0.30	-0.30	-0.30	-0.30	-0.30	-0.30
	maximum	$p_{1max}$	[bar]	0.50	0.50	0.50	0.50	0.50	0.50	0.50	0.50
Pressure at outlet**	max. continuous	$p_{2n}$	[bar]	250	250	250	250	230	200	200	160
	maximum	$p_{2max}$	[bar]	300	300	300	290	270	250	230	200
	peak	$p_3$	[bar]	310	310	310	300	280	260	240	210
Nominal flow rate (min.) at $n_n$ and $p_{2n}$		$Q_n$	[dm <sup>3</sup> .min <sup>-1</sup> ]	10.70	13.60	16.40	22.00	28.00	35.10	39.10	44.40
Maximum flow rate at $n_{max}$ a $p_{2max}$		$Q_{max}$	[dm <sup>3</sup> .min <sup>-1</sup> ]	25.12	31.74	38.33	51.58	64.79	80.66	84.29	89.09
Nominal input power (max.) at $n_n$ and $p_{2n}$		$P_n$	[kW]	5.83	7.37	8.90	11.97	13.83	14.98	16.69	15.12
Maximum input power at $n_{max}$ a $p_{2max}$		$P_{max}$	[kW]	15.42	19.49	23.54	30.64	35.93	41.53	40.07	37.06
Weight		$m$	[kg]	5.15	5.30	5.40	5.55	5.70	5.85	6.00	6.20

Nominal Size Parameters		Sym.	Unit.	UD 5	UD 39	UDD 17	UDD 22	UDD 25	UDD 28	UDD 34	UDD 39
Actual displacement		$V_g$	[cm <sup>3</sup> ]	5.01	40.07	17.12	22.54	25.46	28.38	34.23	40.07
Rotation speed	nominal	$n_n$	[min <sup>-1</sup> ]	1500	1200	1500	1500	1500	1500	1500	1200
	minimum	$n_{min}$	[min <sup>-1</sup> ]	600	400	450	450	450	450	450	400
	maximum	$n_{max}$	[min <sup>-1</sup> ]	3200	1800	3200	3200	3200	3000	2500	1800
Pressure at inlet*	minimum	$p_{1min}$	[bar]	-0.30	-0.30	-0.30	-0.30	-0.30	-0.30	-0.30	-0.30
	maximum	$p_{1max}$	[bar]	0.50	0.50	0.50	0.50	0.50	0.50	0.50	0.50
Pressure at outlet**	max. continuous	$p_{2n}$	[bar]	250	120	250	250	250	240	190	160
	maximum	$p_{2max}$	[bar]	300	160	280	270	260	260	200	170
	peak	$p_3$	[bar]	310	170	290	280	270	270	210	180
Nominal flow rate (min.) at $n_n$ and $p_{2n}$		$Q_n$	[dm <sup>3</sup> .min <sup>-1</sup> ]	6.60	44.20	23.10	32.40	35.10	39.10	46.50	43.50
Maximum flow rate at $n_{max}$ a $p_{2max}$		$Q_{max}$	[dm <sup>3</sup> .min <sup>-1</sup> ]	15.84	71.40	52.29	69.24	78.21	81.73	82.15	69.24
Nominal input power (max.) at $n_n$ and $p_{2n}$		$P_n$	[kW]	3.68	14.14	12.59	16.57	18.72	20.03	19.13	18.86
Maximum input power at $n_{max}$ a $p_{2max}$		$P_{max}$	[kW]	9.73	24.04	30.08	38.19	41.53	43.40	33.56	24.04
Weight		$m$	[kg]	5.00	6.55	5.70	6.00	6.10	6.25	6.50	6.90

\* Inlet pressure in the reversible design can be up to  $p_1 = p_{2n} - 70 \text{ bar max}$ . External drainage must be used in case of the reversible design.

\*\* Outlet pressure in the reversible design is **10% lower** than shown in the table (depending on operating conditions – it is necessary to consult with the manufacturer).

## FORMULAS USED FOR CALCULATION

Flow rate  
 $Q$

$$Q = \frac{V_g \cdot n}{1000} \cdot \eta_v \quad [\text{dm}^3 \cdot \text{min}^{-1}]$$

$V_g$  [cm<sup>3</sup>] pump displacement  
 $n$  [min<sup>-1</sup>] rotation speed  
 $\eta_v$  [-] volumetric efficiency

Displacement  
 $V_g$

$$V_g = \frac{Q \cdot 1000}{n \cdot \eta_v} \quad [\text{cm}^3]$$

Torque  
 $M_k$

$$M_k = \frac{V_g \cdot p}{20 \cdot \pi \cdot \eta_m} \quad [\text{Nm}]$$

$p$  [bar] required pressure at outlet  
 $\eta_m$  [-] mechanical efficiency

Input power  
 $P$

$$P = \frac{V_g \cdot n \cdot p}{600 \cdot 1000 \cdot \eta_t} \quad [\text{kW}]$$

$\eta_t$  [-] total efficiency

## PUMP EFFICIENCIES

Volumetric efficiency

$\eta_v$

It determines the amount of flow losses. Its value is  $\eta_v = 0,92 \div 0,98$  (depending on rotation speed, viscosity of working liquid and outlet pressure). It can be expressed as follows:

$$\eta_v = \frac{Q_{act.}}{Q_{theor}} \quad [-]$$

$Q_{act.}$  [dm<sup>3</sup> · min<sup>-1</sup>] actual flow rate  
 $Q_{theor}$  [dm<sup>3</sup> · min<sup>-1</sup>] theoretical flow rate

Mechanical efficiency

$\eta_m$

It determines mechanical losses. Its value is about  $\eta_m = 0,85$ . It can be expressed as follows:

$$\eta_m = \frac{M_{theor}}{M_{act.}} \quad [-]$$

$M_{act.}$  [Nm] actual torque  
 $M_{theor}$  [Nm] theoretical torque

Total efficiency

$\eta_t$

t is defined as product of  $\eta_n$  and  $\eta_m$  and determines difference between theoretical and actual required input power:

$$\eta_t = \eta_v \cdot \eta_m = \frac{P_{theor}}{P_{act.}} \quad [-]$$

$P_{act.}$  [kW] actual input power  
 $P_{theor}$  [kW] theoretical input power

## WORKING LIQUID

- Mineral oils for hydraulic drives
- Hydraulic liquids based on plant oils suitable for hydraulic drives

### Liquid temperature

- $t = -20 \div +80$  [°C]  
when used with FKM (Viton) seal up to 120 [°C]

### Cinematic viscosity

- Recommended (during continuous operation):  $\nu = 20 \div 80 \cdot 10^{-6} [\text{m}^2 \cdot \text{s}^{-1}]$
- Maximum (cold starting, at viscosity  $>1000$ , operating pressure  $<10$  bar is permissible, speed  $<1500 \cdot \text{min}^{-1}$ ):  $\nu = 1200 \cdot 10^{-6} [\text{m}^2 \cdot \text{s}^{-1}]$
- Minimum (operating mode at  $10 \cdot 10^{-6}$  up  $20 \cdot 10^{-6}$  should be consulted with manufacturer):  $\nu = 10 \cdot 10^{-6} [\text{m}^2 \cdot \text{s}^{-1}]$

### Filtration coefficient $\beta_{\alpha}$

$\beta_{25\ 75} \geq$  (for pressure  $p_2 < 200$  bar)  
 $\beta_{10\ 75} \geq$  (for pressure  $p_2 > 200$  bar)

### Liquid contamination class according to ISO 4406

21/18/15 (for pressure  $p_2 < 200$  bar)  
20/17/14 (for pressure  $p_2 > 200$  bar)

### Liquid contamination class according to NAS 1638

10 (for pressure  $p_2 < 200$  bar)  
8 (for pressure  $p_2 > 200$  bar)

## PRESSURE LOAD

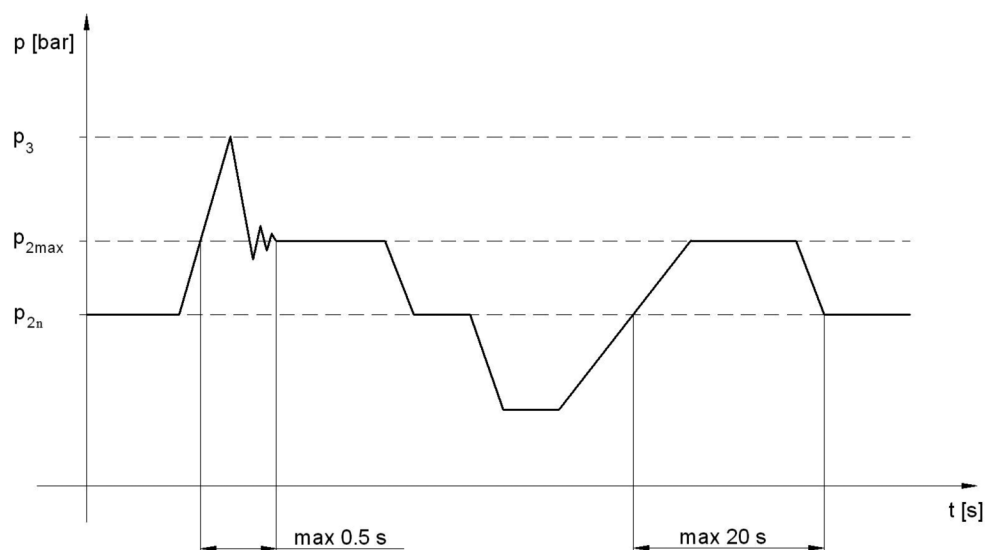

- $p_{2n}$  **max. contin. pressure** Max. working pressure, at which the pump can be operated without time limitation.
- $p_{2max}$  **max. pressure** Maximum pressure permissible for a short time, max. 20s.
- $p_3$  **peak pressure** Short-time pressure (fractions of a second) arising in case of a sudden change of the operating mode; any excess of this pressure during operation is impermissible.

## DIRECTION OF ROTATION

- Determine direction of rotation by looking at the drive shaft. The pump can only be used in the specified direction of rotation.

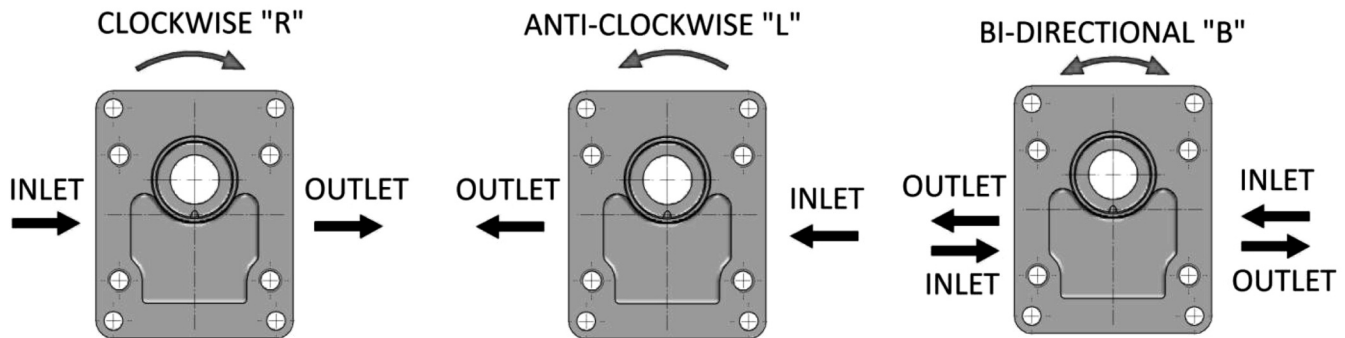

## OTHER REQUIREMENTS

- Technical requirements for multiple pumps are the same as for single version pumps.
  - In case of multiple pumps the maximum torque, which transfer clutch between each sections, is 110 Nm. Therefore, caution should be used while burdening more sections at once (see allowable torques on the output shaft and the clutch).
  - Section 1 should be burdened by the product of pressure and flow more than section 2

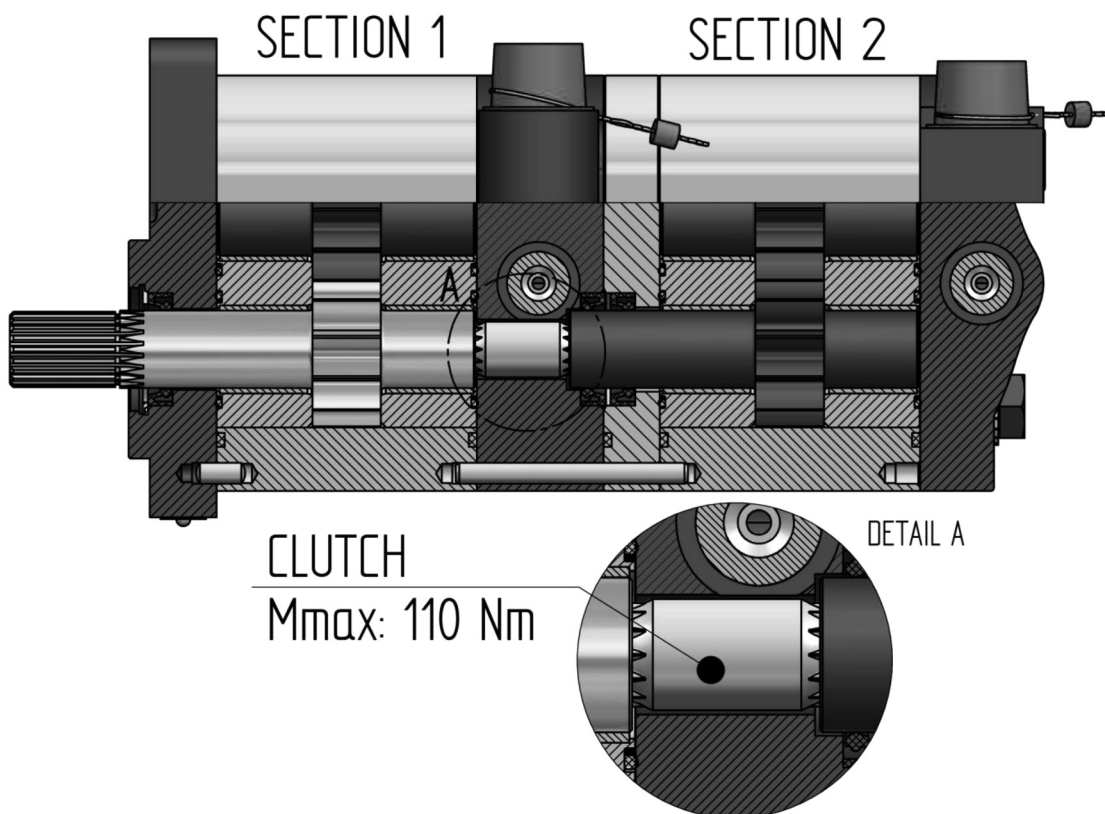

# ALLOWABLE TORQUE ON THE OUTPUT SHAFT DEPENDENT ON PRESSURE

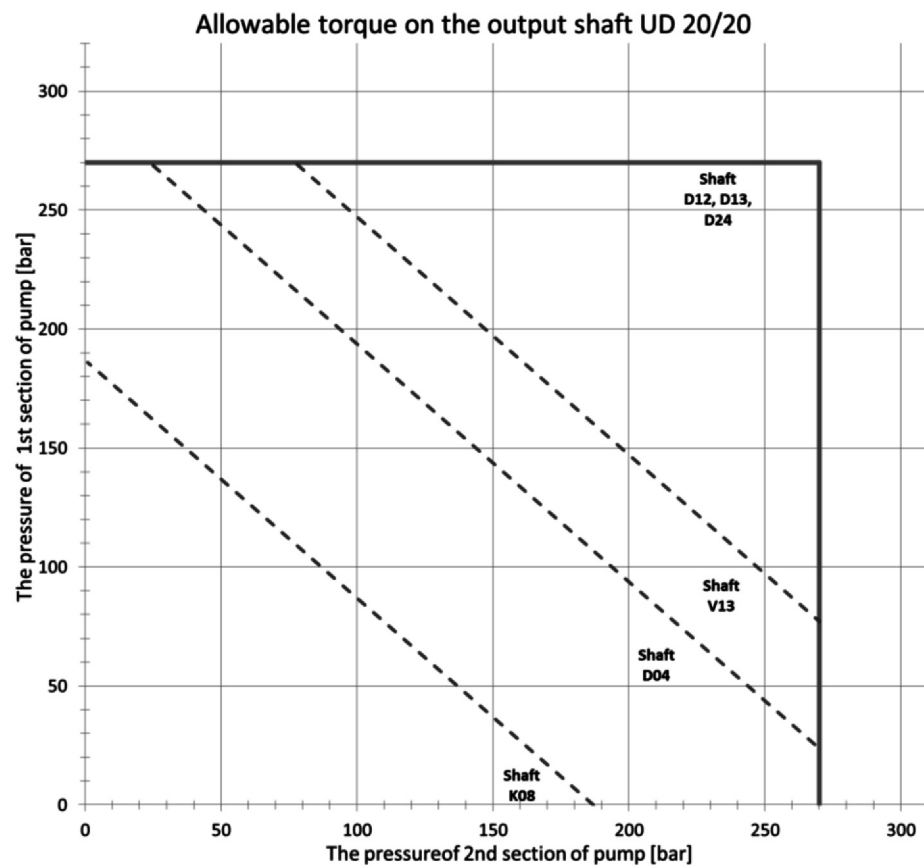
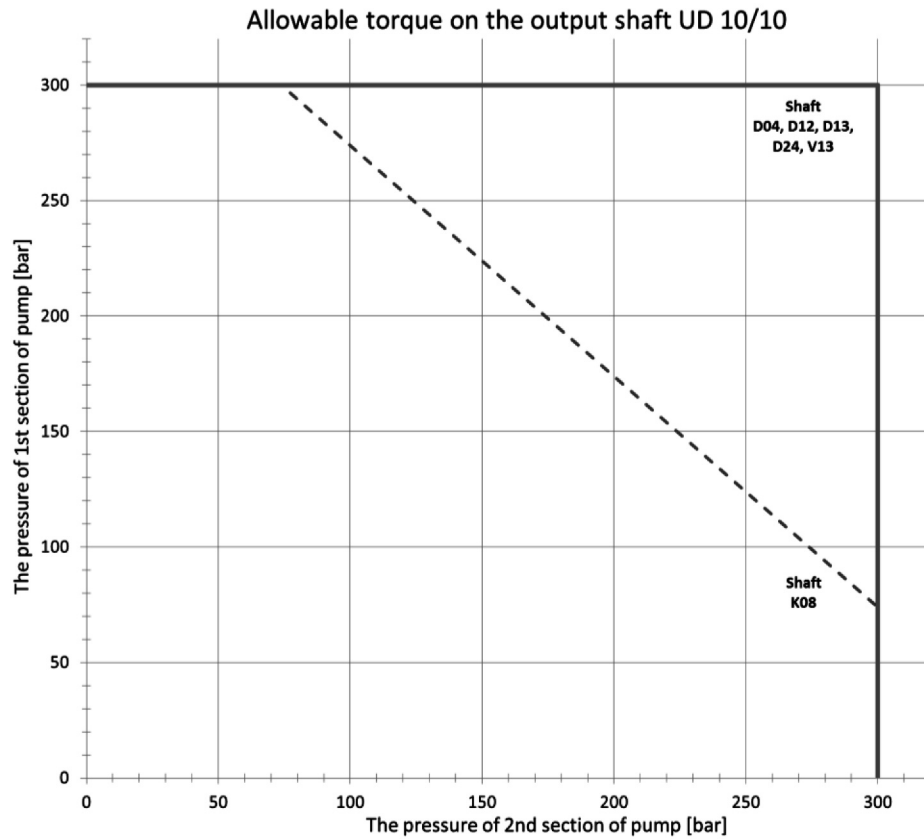

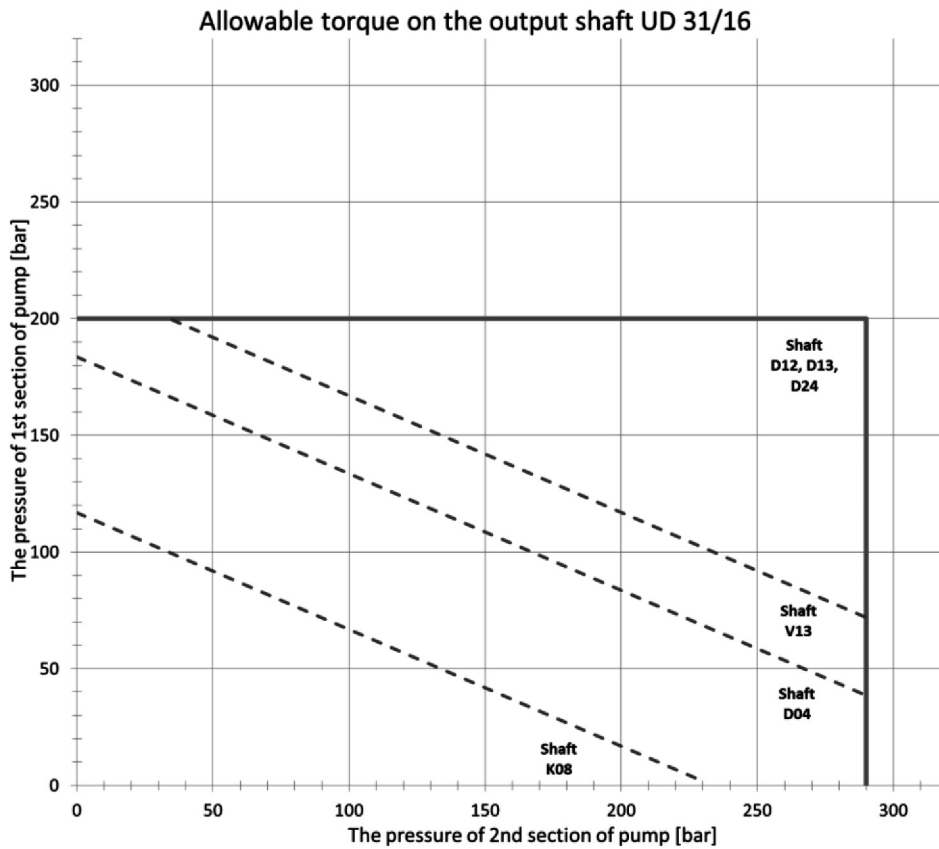

## REVERSIBLE DESIGN

- Pumps with the possibility of bidirectional rotation have a different internal arrangement requiring drainage. Two types of drain are used - internal and external. The internal drainage is always interconnected with the outlet by means of valves. The external drainage is solved by an orifice located in the cover opposite the driven gear. (see fig.). Maximum pressure in the drainage of the serial version (standard seal shaft) is 0.5 bar.

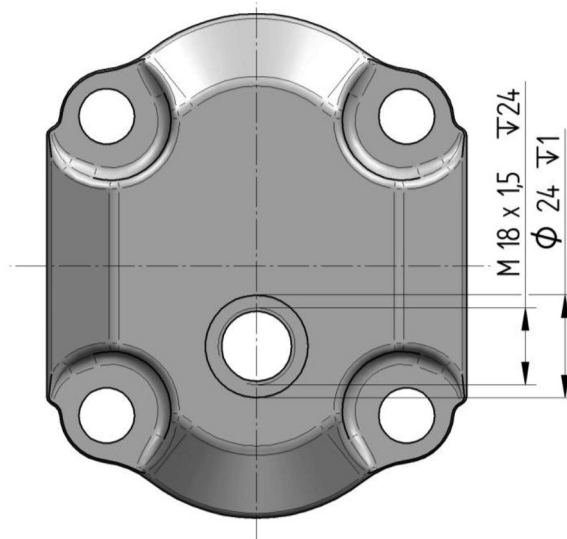

## PUMP WITH FRONT-END BEARING

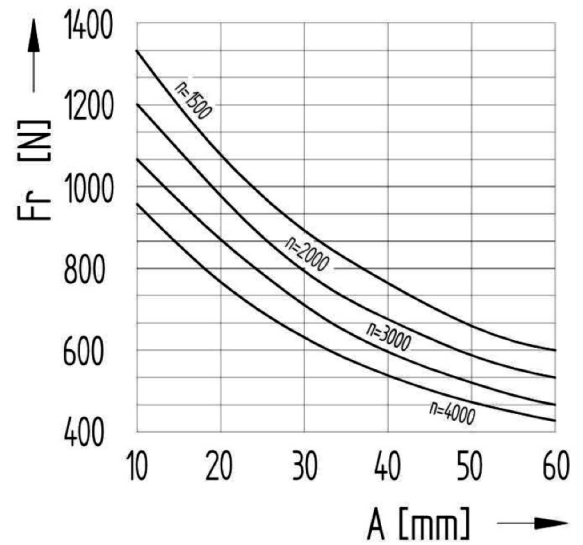
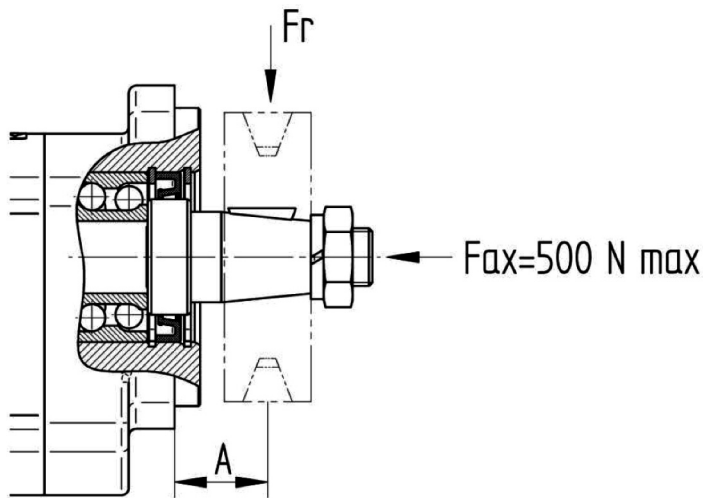

Without front-end bearing the driven unit must not impart axial or radial load of the driven shaft once the engine has been connected to it!

## FLOW REGULATOR FOR UNIDIRECTIONAL PUMP

- The pump may be equipped with liquid flow regulator, which is designed to maintain constant flow rate regardless of the pump RPM. This principle can be used everywhere, where there is a requirement for motion control at constant speed regardless of RPM. The value of flow rate is determined by type of aperture (see the following figures).

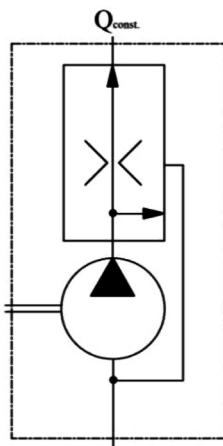

Three way flow control valve

Excess flow returned to suction line

$$Q_{konst} = 2-30 \text{ l/min}$$

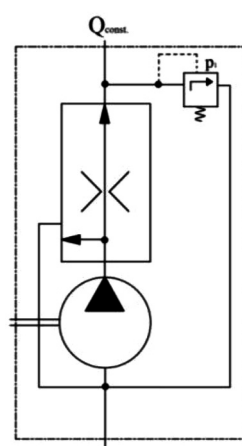

Three way flow control valve with pressure-relief valve

Excess flow returned to suction line

$$Q_{konst} = 2-30 \text{ l/min, } p_1 = 5-250 \text{ bar}$$

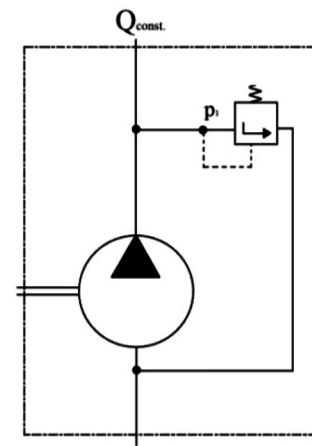

Pressure-relief valve

Discharge returned to suction line

$$p_1 = 5-250 \text{ bar}$$

Note: The setting values of the safety valve must be consulted with the producer.

## UD FLOW RATE AND POWER CURVES

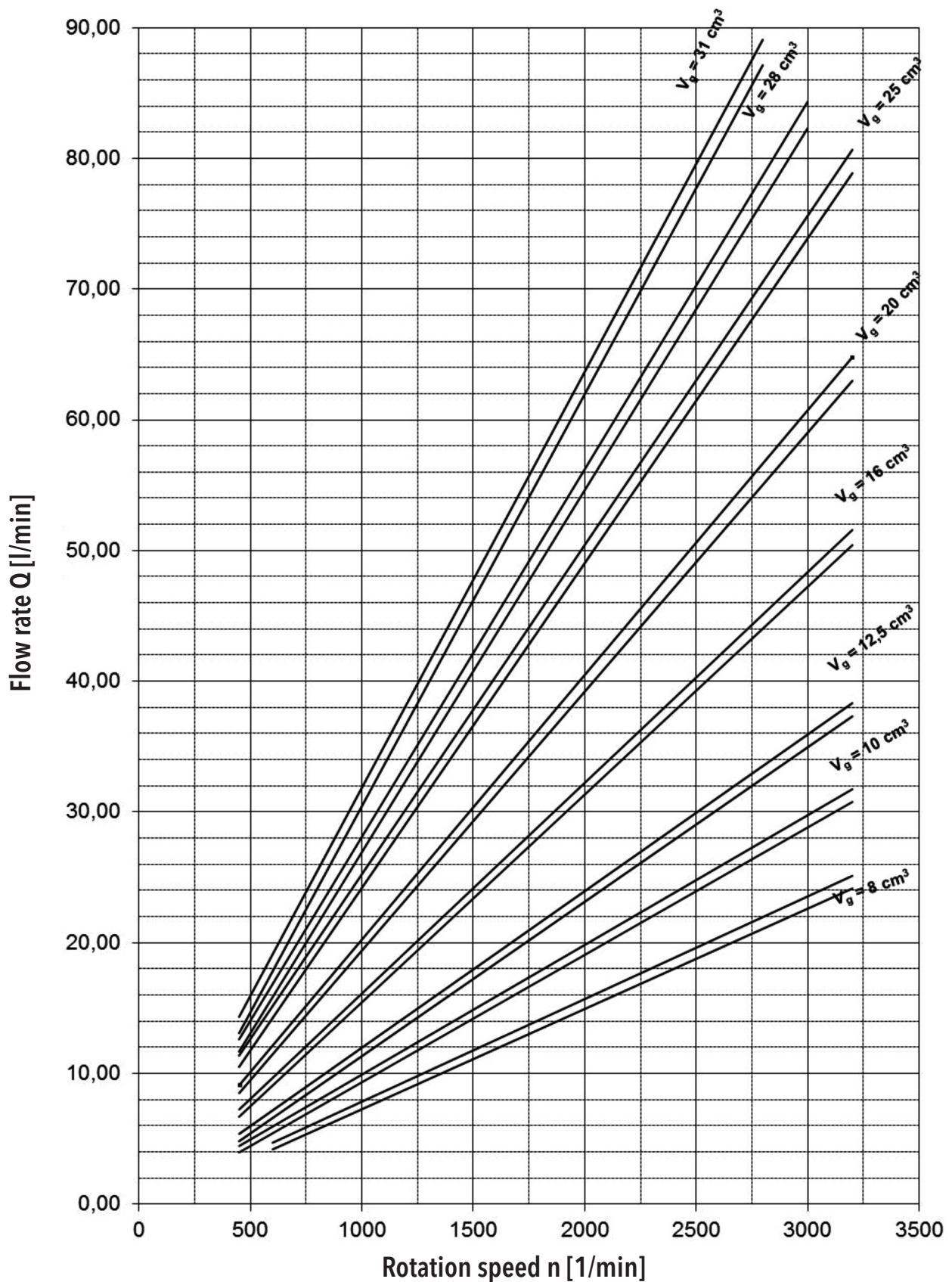

The above characteristics apply for oil ISO Vg 46 at a temperature  $t=45\text{ }^{\circ}\text{C}$ .

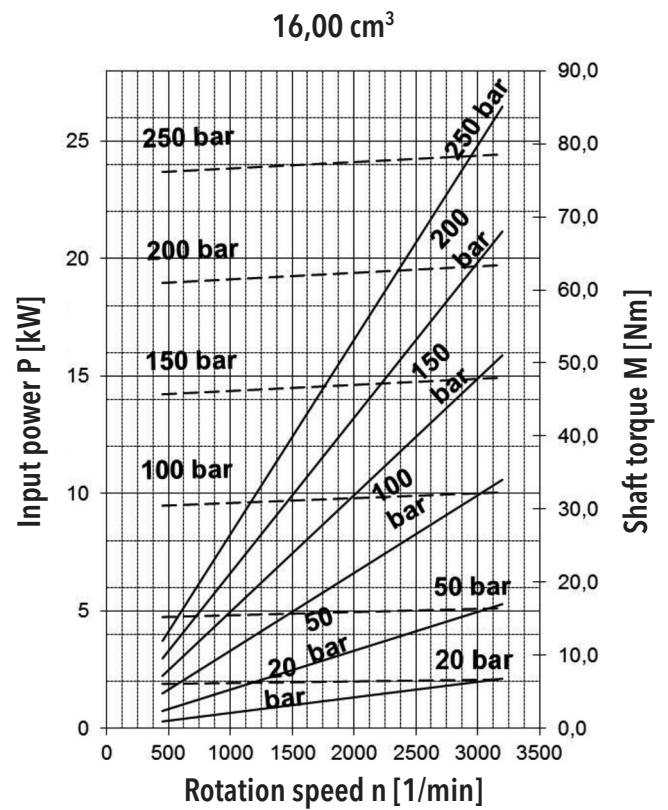
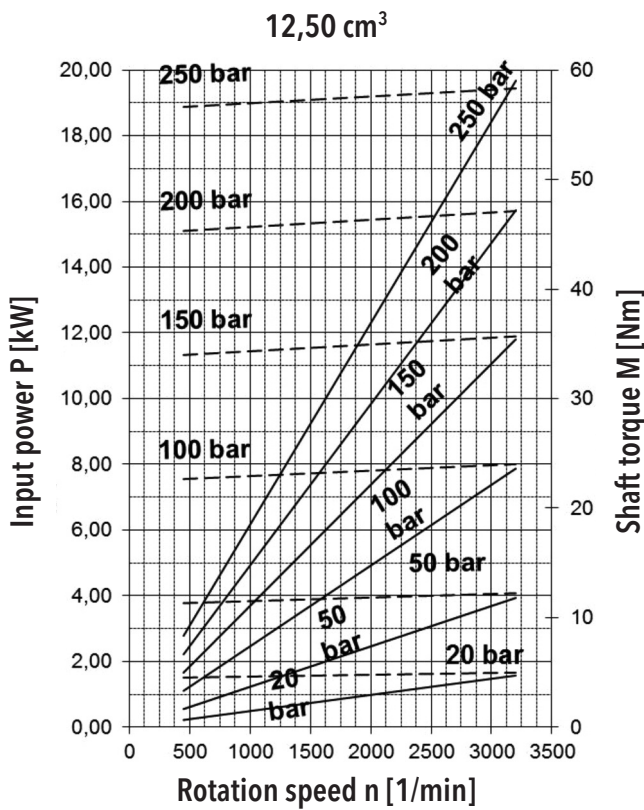
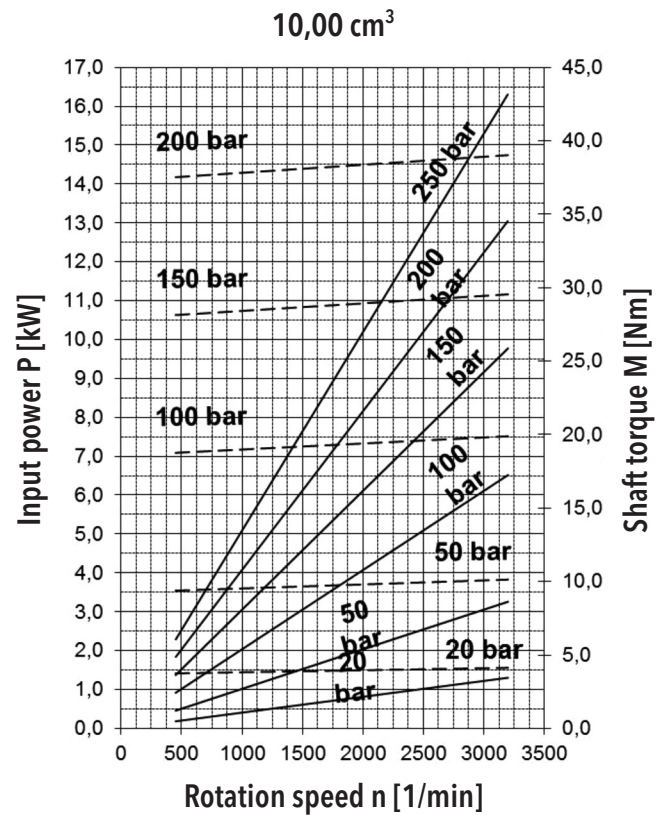
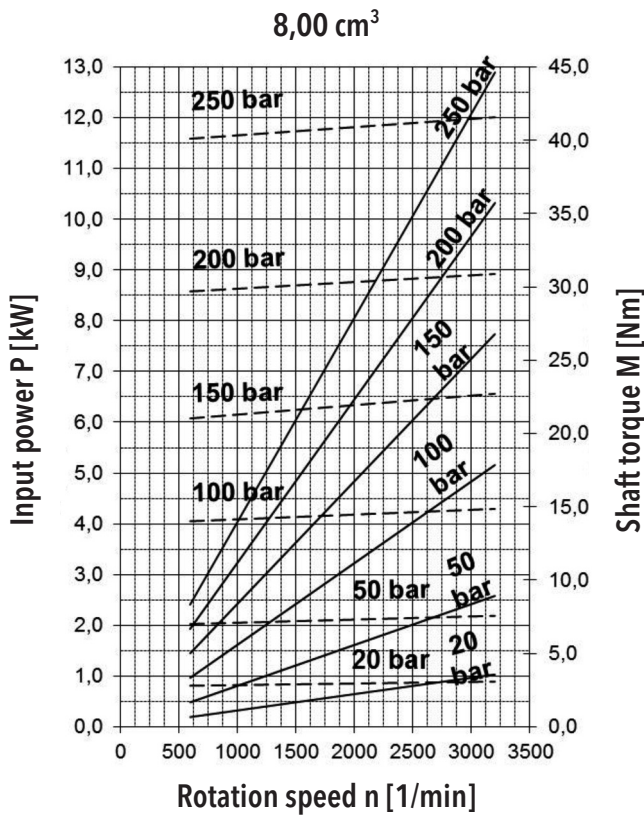

20,00 cm<sup>3</sup>

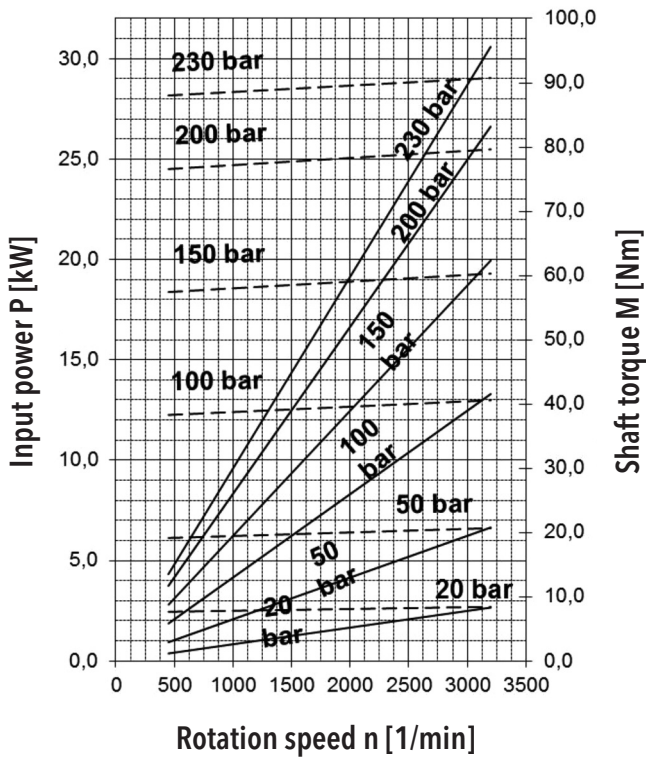

25,00 cm<sup>3</sup>

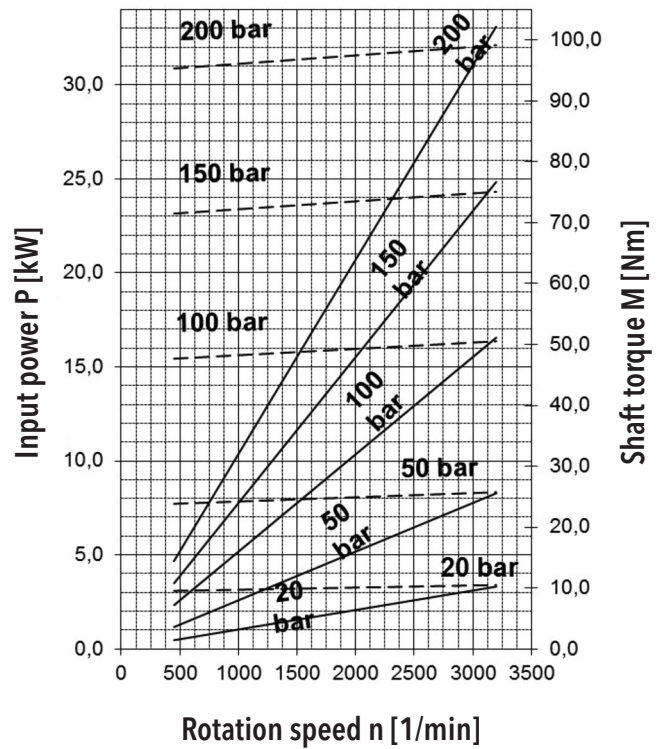

28,00 cm<sup>3</sup>

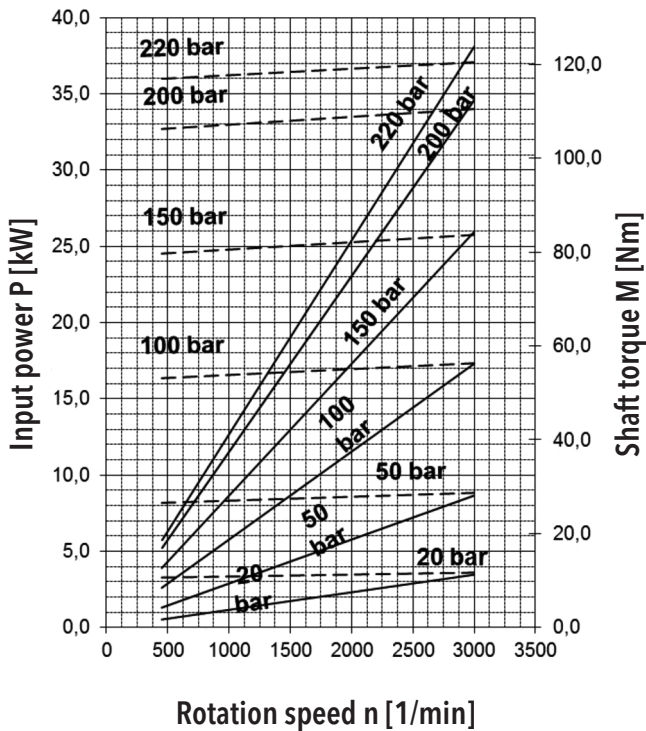

31,00 cm<sup>3</sup>

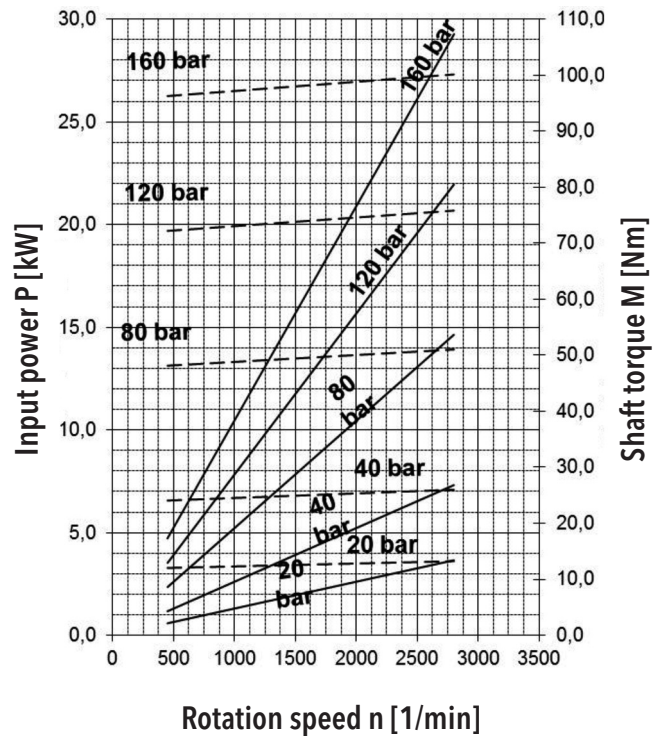







## ORDER KEY - SIMPLE VERSION







**UD - 16 R - R08 D12 - S M09 M07 - V . 000**



Code	Type
UD	UD Series Gear Pump
UDK	UD Series Gear Pump, shortened version
UDD	UD Series Gear Pump, reinforced version

Code	Displacement [cm <sup>3</sup> ]
5,0	5,01
8,0	7,93
10,0	10,02
12,5	12,10
16,0	16,28
20,0	20,45
25,0	25,46
28,0	28,38
31,0	32,14
39,0	40,07
XX	Other displacements on request

Code	Direction of rotation
R	Clockwise rotation
L	Anti-clockwise rotation
B	Reversible rotation





Code	Flange design
R08	 Rectangular flange, centre ring Ø62, spacing 86x120, with O-ring
R09	 Rectangular flange, centre ring Ø62, spacing 86x120
R10	 Rectangular flange, centre ring Ø63, spacing 76x96
S02	 SAE A, centre ring Ø82,55, 2 aperture, spacing 106,4
S03	 SAE B, centre ring Ø101,6, 2 aperture, spacing 146
K01	 Centre ring Ø62, 2 bolts, spacing 115
Z	Special desing

Code	Drive shaft desing
D04	 Spline SAE 5/8"
D12	 Spline 22x1
D13	 Spline SAE 7/8"
D24	 Spline 6x18x22
K08	 Cross coupling
V13	 Cylindric
Z	Special desing

Code	Location of inlets and outlets
S	 Side (in the body)
R	 Axial (in the cover)
C	 Combination

Code	Special arrangements
-	Without special arrangement
001	Rectangular flange, 2 holes
080	Double-edged seal FPN
200	With front-end bearing

Code	Sealing material
V	FPN (VITON)
N	NBR

Code	Liquid inlet and outlet connection shape
M03	Thread M 14x1,5
M05	Thread M 18x1,5
M06	 Thread M 20x1,5
M07	Thread M 22x1,5
M09	Thread M 27x2
M12	Thread M 33x2
G03	Thread BSP G1/2
G04	 Thread BSP G3/4
G05	Thread BSP G1
G06	Thread BSP G1 1/4
H05	Flange fitting 4xM6/Ø35; Ø15
H06	 Flange fitting 4xM6/Ø40; Ø20
H08	Flange fitting 4xM6/Ø30; Ø13,5
H11	Flange fitting 4xM10/Ø51; Ø26
K03	 Flange fitting 4xM8/Ø40; Ø18
E02	Flange fitting 3/4
E03	Flange fitting 1
E04	Flange fitting 1 1/4
Z	Special desing

An example of designation for the UD anti-clockwise pump with displacement 16 cm<sup>3</sup>, rectangular flange with center ring Ø62 without O-ring, spline 22x1, input and output in body with metric thread and standard seal NBR without special arrangements: **UD-16L-R09D12-SM09M07-N**

## ORDER KEY - MULTIPLE VERSION

**UD - 16 / 16 R - R08 D12 - S M09 M07 / M09 M07 - V . 000**

Code	Type
UD	UD Series Gear Pump
UDK	UD Series Gear Pump, shortened version
UDD	UD Series Gear Pump, reinforced version

Code	Displacement [cm <sup>3</sup> ]
5,0	5,01
8,0	7,93
10,0	10,02
12,5	12,10
16,0	16,28
20,0	20,45
25,0	25,46
28,0	28,38
31,0	32,14
39,0	40,07
XX	Other displacements on request

Code	Direction of rotation
R	Clockwise rotation
L	Anti-clockwise rotation
B	Reversible rotation

Code	Flange design	
R08		Rectangular flange, centre ring $\varnothing 62$ , spacing 86x120, with O-ring
R09		Rectangular flange, centre ring $\varnothing 62$ , spacing 86x120
R10		Rectangular flange, centre ring $\varnothing 63$ , spacing 76x96
S02		SAE A, centre ring $\varnothing 82,55$ , 2 aperture, spacing 106,4
S03		SAE B, centre ring $\varnothing 101,6$ , 2 aperture, spacing 146
K01		Centre ring $\varnothing 62$ , 2 bolts, spacing 115
Z		Special desing

Code	Location of inlets and outlets	
S		Side (in the body)
C		Combination

Code	Special arrangements
-	Without special arrangementst
001	Rectangular flange, 2 holes
080	Double-edged seal FPN
200	With front-end bearing

Code	Sealing material
V	FPN (VITON)
N	NBR

Code	Liquid inlet and outlet connection shape	
M03		Thread M 14x1,5
M05		Thread M 18x1,5
M06		Thread M 20x1,5
M07		Thread M 22x1,5
M09		Thread M 27x2
M12		Thread M 33x2
G03		Thread BSP G1/2
G04		Thread BSP G3/4
G05		Thread BSP G1
G06		Thread BSP G1 1/4
H05		Flange fitting 4xM6/ $\varnothing 35$ ; $\varnothing 15$
H06		Flange fitting 4xM6/ $\varnothing 40$ ; $\varnothing 20$
H08		Flange fitting 4xM6/ $\varnothing 30$ ; $\varnothing 13,5$
H11		Flange fitting 4xM10/ $\varnothing 51$ ; $\varnothing 26$
K03		Flange fitting 4xM8/ $\varnothing 40$ ; $\varnothing 18$
E02		Flange fitting 3/4
E03		Flange fitting 1
E04		Flange fitting 1 1/4
Z		Special desing

Code	Drive shaft desing	
D04		Spline SAE 5/8"
D12		Spline 22x1
D13		Spline SAE 7/8"
D24		Spline 6x18x22
K08		Cross coupling
V13		Cylindric
Z		Special desing

An Example of designation for the UD two-section anti-clockwise pump with displacements 20 and 16 cm<sup>3</sup>, rectangular flange with center ring  $\varnothing 62$  without O-ring, spline 22x1, input and output in body with metric thread and standard seal NBR without special arrangements: **UD-20/16L-R09D12-SM09M07/M09M07-N**

Note: In case of combination inlets, with the code „C” is respected following sequence of inlets and outlets:

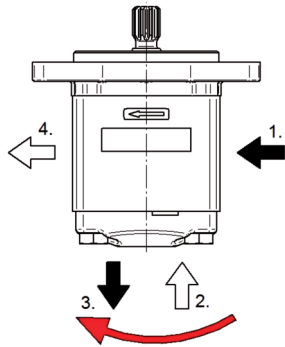

For clockwise and reverse gear pump,  
in direction clockwise

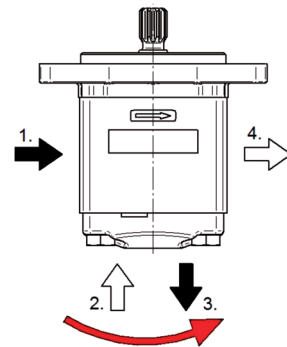

For anti-clockwise gear pump,  
in direction anti-clockwise

For ex....: UD-16R-S02D04-CG04 G04 G03 -N  
1. 2. 3. 4.

## COMBINATIONS OF FLANGES AND SHAFTS

		FLANGE DESIGN					
		R08	R09	R10	S02	S03	K01
DRIVE SHAFT	D04						
	D12	●	●		●		
	D13					●	●
	D24			●			
	K08	●	●				
	V13	●	●				

## FLANGES DESIGN

R08:

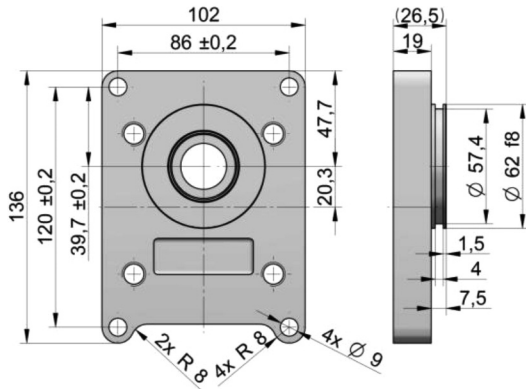

R09:

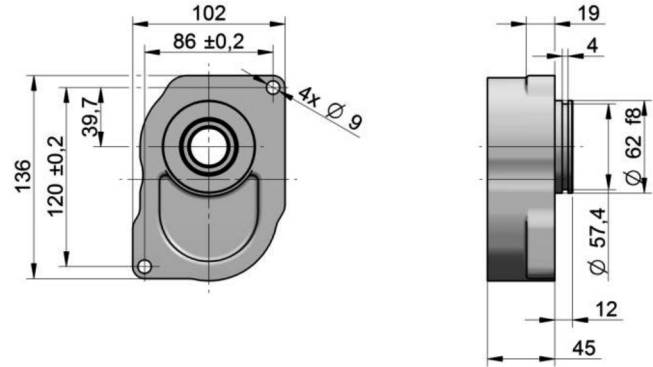

R10:

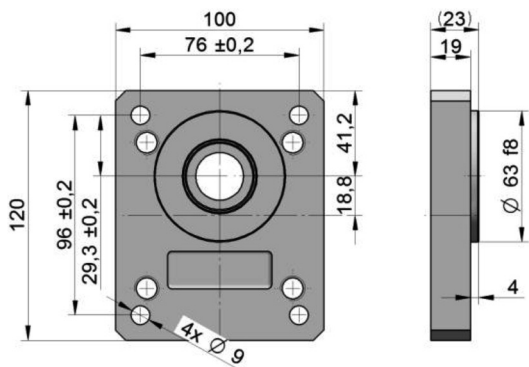

S02:

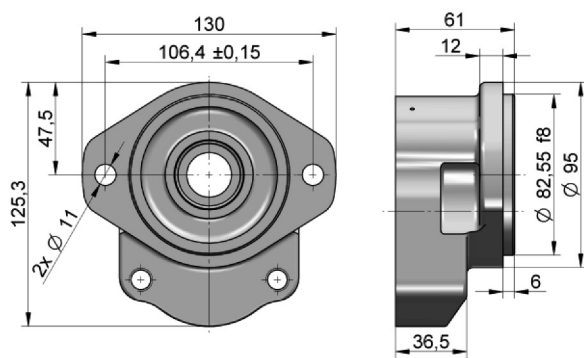

S03:

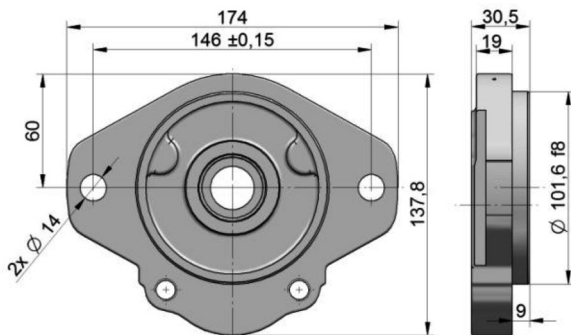

K01:

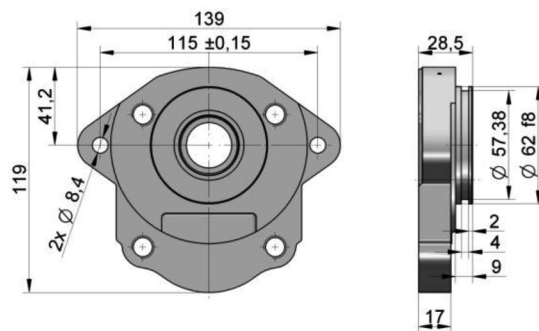

## DRIVE SHAFTS

**D04:**

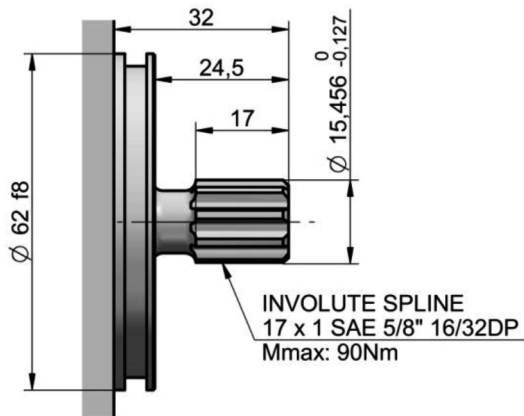

**D12:**

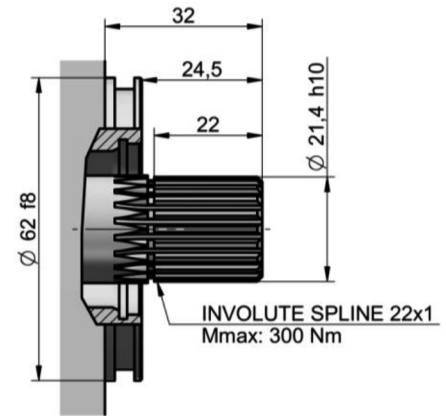

**D13:**

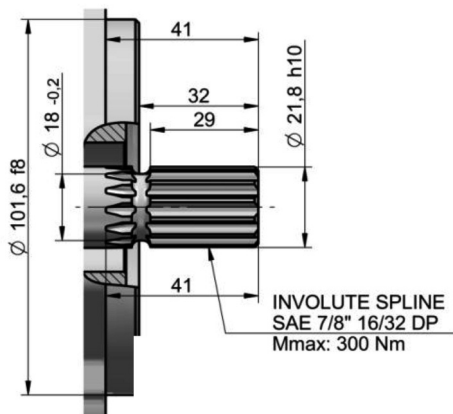

**D24:**

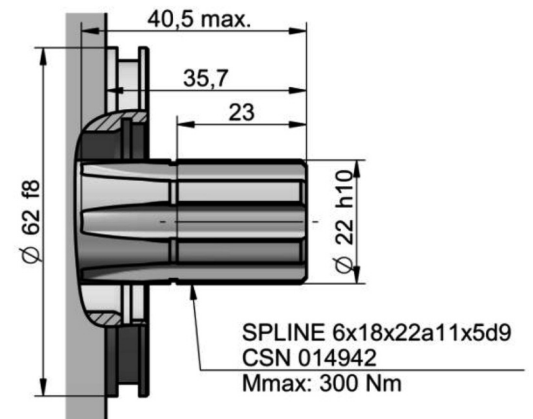

**K08:**

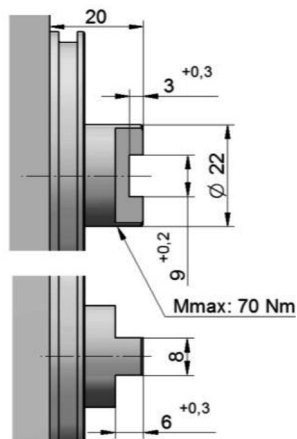

**V13:**

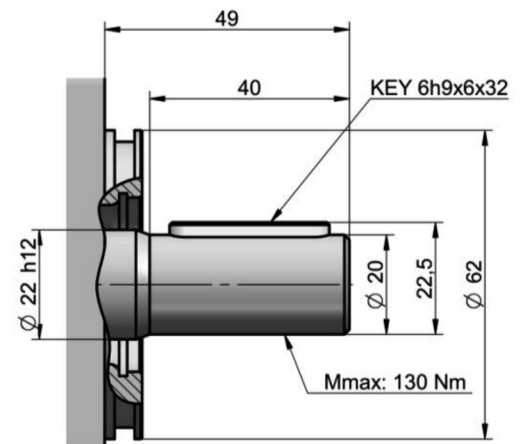

## LIQUID INLET AND OUTLET CONNECTION

Metric thread according to ISO 6149

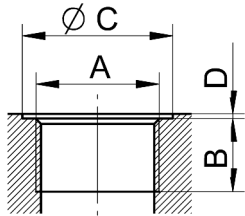

Code	A	B	C	D
M03	M 14 x 1.5	13	22	1
M05	M 18 x 1.5	14	24	1
M06	M 20 x 1.5	14	26	1
M07	M 22 x 1.5	14	28	1
M09	M 27 x 2.0	16	33	1
M12	M 33 x 2.0	18	40	1

BSPP pipe thread according to ISO 228-1:

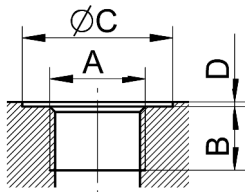

Code	A	B	C	D
G03	G 1/2"	14	33	1
G04	G 3/4"	16	39	1
G05	G 1"	18	45	1
G06	G 1 1/4"	18	57	1

Flanged fittings according to DIN 8901/8902:

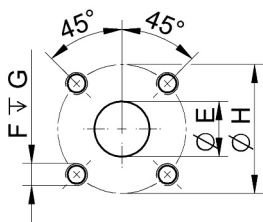

Code	E	F	G	H
H05	15.0	M6	13	35
H06	20.0	M6	13	40
H07	13.5	M6	13	30
H11	26.0	M10	16	51

Flanged fittings - „cross“:

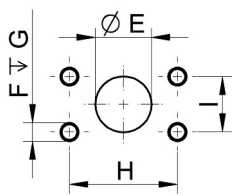

Code	E	F	G	H
K03	18	M8	16	40

Flanged fittings according to SAE, metric thread:

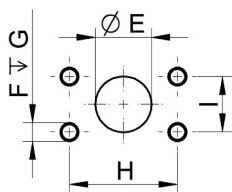

Code	E	F	G	H	I
E02	19.0	M10	18	47.6	22.2
E03	25.4	M10	18	52.4	26.2
E04	30.5	M10	18	58.7	30.2

Drains:

Code	E	F	G	H
M05	M18x1.5	14	24	1

## CATALOGUE SHETS OF UD SERIES BASIC DESIGNS

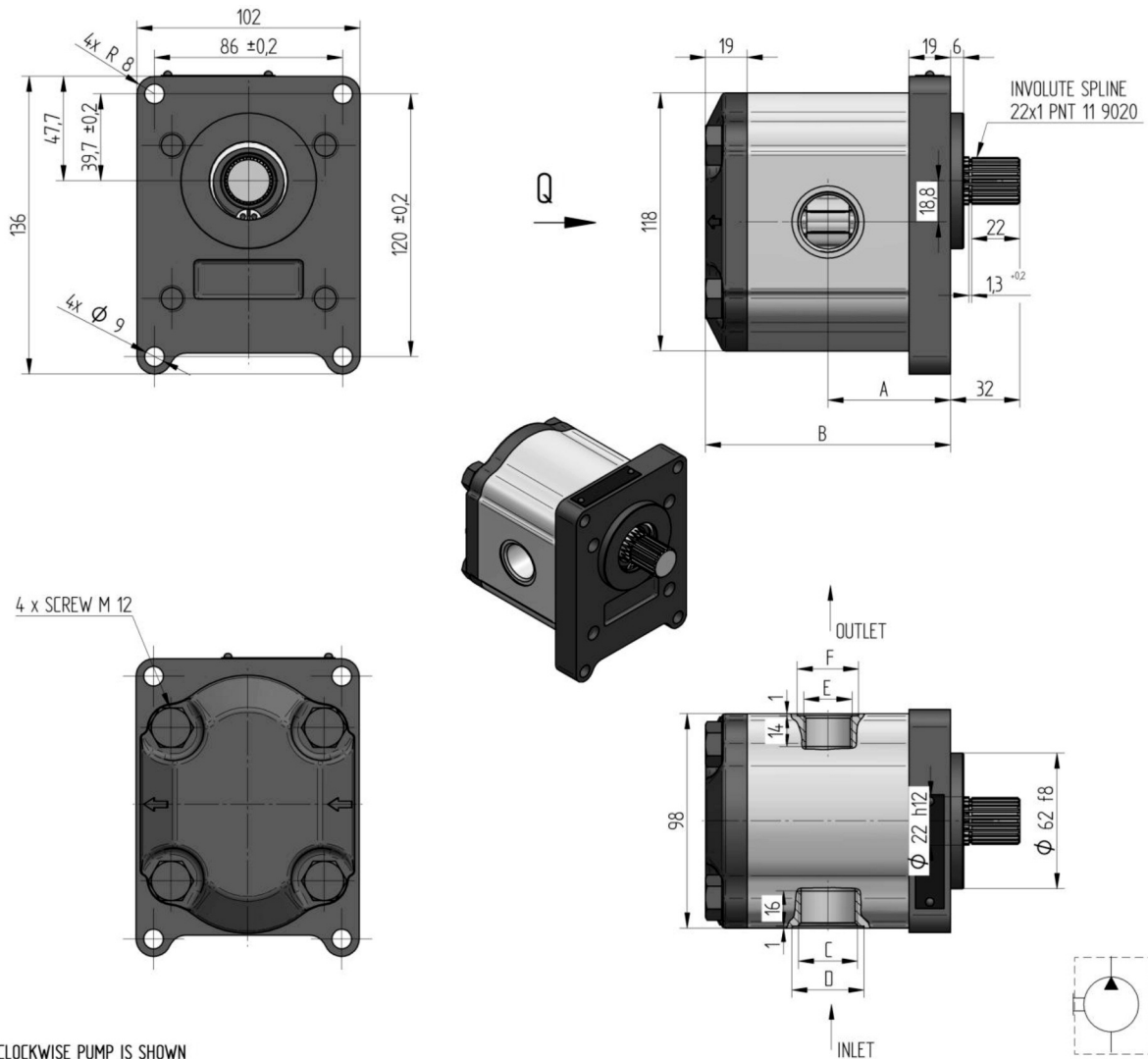

CLOCKWISE PUMP IS SHOWN

Order key	purch. code	direct. of rot.	displacement [cm <sup>3</sup> /1]	nom. press. [bar]	speed MIN. [min <sup>-1</sup> ]	speed MAX. [min <sup>-1</sup> ]	dimension					
							A [mm]	B [mm]	C [mm]	D [mm]	E [mm]	F [mm]
UD-31R-R08D12-SM09M07-N	183 9476	R	31	200	450	2800	65.50	131.0	M27x2	Ø 33	M22x1.5	Ø 28
UD-31L-R08D12-SM09M07-N	183 9047	L										
UD-28R-R08D12-SM09M07-N		R	28	230	450	3000	63.25	126.5	M27x2	Ø 33	M22x1.5	Ø 28
UD-28L-R08D12-SM09M07-N		L										
UD-25R-R08D12-SM09M07-N	183 9475	R	25	250	450	3200	61.50	123.0	M27x2	Ø 33	M22x1.5	Ø 28
UD-25L-R08D12-SM09M07-N	183 9046	L										
UD-20R-R08D12-SM09M07-N	183 9412	R	20	270	450	3200	58.50	117.0	M27x2	Ø 33	M22x1.5	Ø 28
UD-20L-R08D12-SM09M07-N	183 9413	L										
UD-16R-R08D12-SM09M07-N	183 9406	R	16	290	450	3200	56.00	112.0	M27x2	Ø 33	M22x1.5	Ø 28
UD-16L-R08D12-SM09M07-N	183 9407	L										
UD-12,5R-R08D12-SM09M07-N		R	12.5	300	450	3200	53.50	107.0	M27x2	Ø 33	M22x1.5	Ø 28
UD-12,5L-R08D12-SM09M07-N		L										
UD-10R-R08D12-SM09M07-N	183 9400	R	10	300	450	3200	52.25	104.5	M27x2	Ø 33	M22x1.5	Ø 28
UD-10L-R08D12-SM09M07-N	183 9401	L										
UD-8R-R08D12-SM09M07-N		R	8	300	600	3200	51.00	102.0	M27x2	Ø 33	M22x1.5	Ø 28
UD-8L-R08D12-SM09M07-N		L										

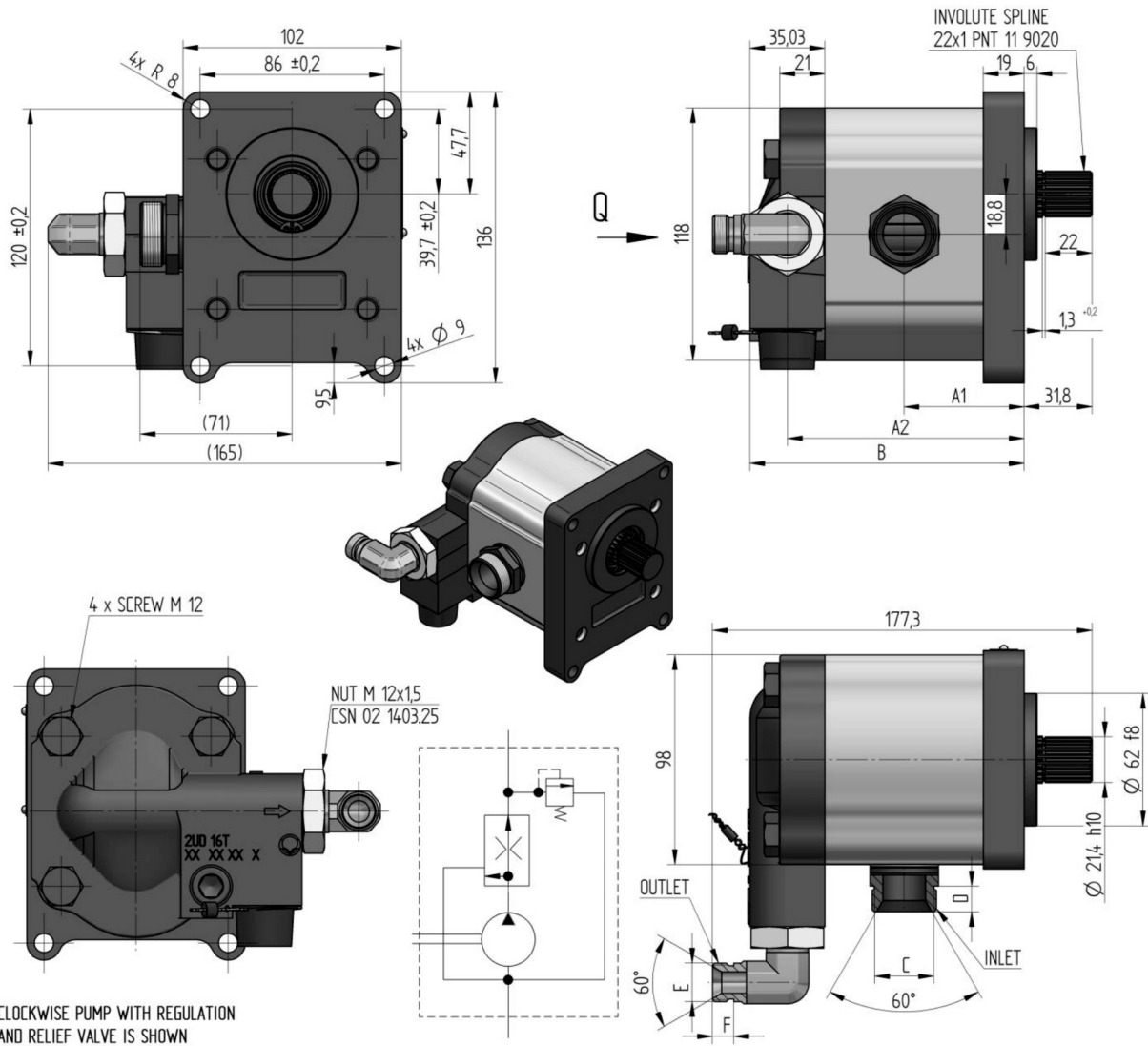

Order key	purch. code	direct. of rot.	displacement [cm <sup>3</sup> /1]	speed MIN. [min <sup>-1</sup> ]	speed MAX. [min <sup>-1</sup> ]	dimension						
						A1 [mm]	A2 [mm]	B [mm]	C [mm]	D [mm]	E [mm]	F [mm]
UD-31R-R09D12-SZZ-V		R	31	450	2800	65.50	129.5	147.0	M30x2	14	M18x1.5	10
UD-31L-R09D12-SZZ-V		L										
UD-28R-R09D12-SZZ-V		R	28	450	3000	63.25	125.0	142.5	M30x2	14	M18x1.5	10
UD-28L-R09D12-SZZ-V		L										
UD-25R-R09D12-SZZ-V		R	25	450	3200	61.50	121.5	139.0	M30x2	14	M18x1.5	10
UD-25L-R09D12-SZZ-V		L										
UD-20R-R09D12-SZZ-V		R	20	450	3200	58.50	115.5	133.0	M30x2	14	M18x1.5	10
UD-20L-R09D12-SZZ-V		L										
UD-16R-R09D12-SZZ-V	183 9633	R	16	450	3200	56.00	110.5	128.0	M30x2	14	M18x1.5	10
UD-16L-R09D12-SZZ-V		L										
UD-12.5R-R09D12-SZZ-V		R	12.5	450	3200	53.50	105.5	123.0	M30x2	14	M18x1.5	10
UD-12.5L-R09D12-SZZ-V		L										
UD-10R-R09D12-SZZ-V		R	10	450	3200	52.25	103.0	120.5	M30x2	14	M18x1.5	10
UD-10L-R09D12-SZZ-V		L										
UD-8R-R09D12-SZZ-V		R	8	600	3200	51.00	100.5	118.0	M30x2	14	M18x1.5	10
UD-8L-R09D12-SZZ-V		L										

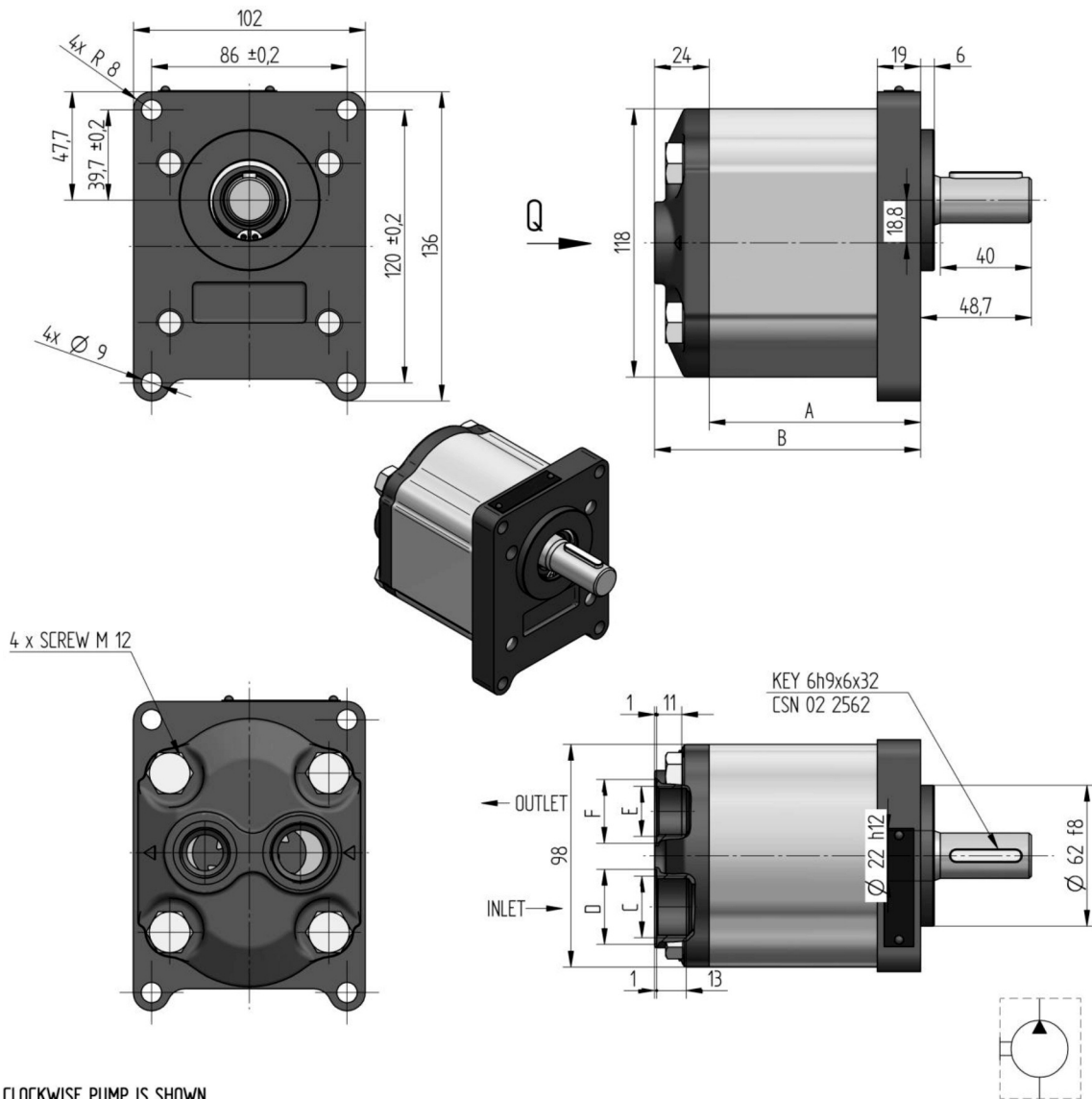

CLOCKWISE PUMP IS SHOWN

Order key	purch. code	direct. of rot.	displacement [cm <sup>3</sup> /1]	nom. press. [bar]	speed MIN. [min <sup>-1</sup> ]	speed MAX. [min <sup>-1</sup> ]	dimension					
							A [mm]	B [mm]	C [mm]	D [mm]	E [mm]	F [mm]
UD-31R-R09V13-RM09M07-N		R	31	200	450	2800	112.0	136.0	M27x2	Ø 33	M22x1.5	Ø 28
UD-31L-R09V13-R M09M07-N		L										
UD-28R-R09V13-RM09M07-N		R	28	230	450	3000	107.5	131.5	M27x2	Ø 33	M22x1.5	Ø 28
UD-28L-R09V13-RM09M07-N		L										
UD-25R-R09V13-RM09M07-N		R	25	250	450	3200	104.0	128.0	M27x2	Ø 33	M22x1.5	Ø 28
UD-25L-R09V13-RM09M07-N		L										
UD-20R-R09V13-RM09M07-N		R	20	270	450	3200	98.0	122.0	M27x2	Ø 33	M22x1.5	Ø 28
UD-20L-R09V13-RM09M07-N		L										
UD-16R-R09V13-RM09M07-N		R	16	290	450	3200	93.0	117.0	M27x2	Ø 33	M22x1.5	Ø 28
UD-16L-R09V13-RM09M07-N		L										
UD-12.5R-R09V13-RM09M07-N		R	12.5	300	450	3200	88.0	112.0	M27x2	Ø 33	M22x1.5	Ø 28
UD-12.5L-R09V13-RM09M07-N		L										
UD-10R-R09V13-RM09M07-N	183 9404	R	10	300	450	3200	85.5	109.5	M27x2	Ø 33	M22x1.5	Ø 28
UD-10L-R09V13-RM09M07-N		L										
UD-8R-R09V13-RM09M07-N		R	8	300	600	3200	83.0	107.0	M27x2	Ø 33	M22x1.5	Ø 28
UD-8L-R09V13-RM09M07-N		L										

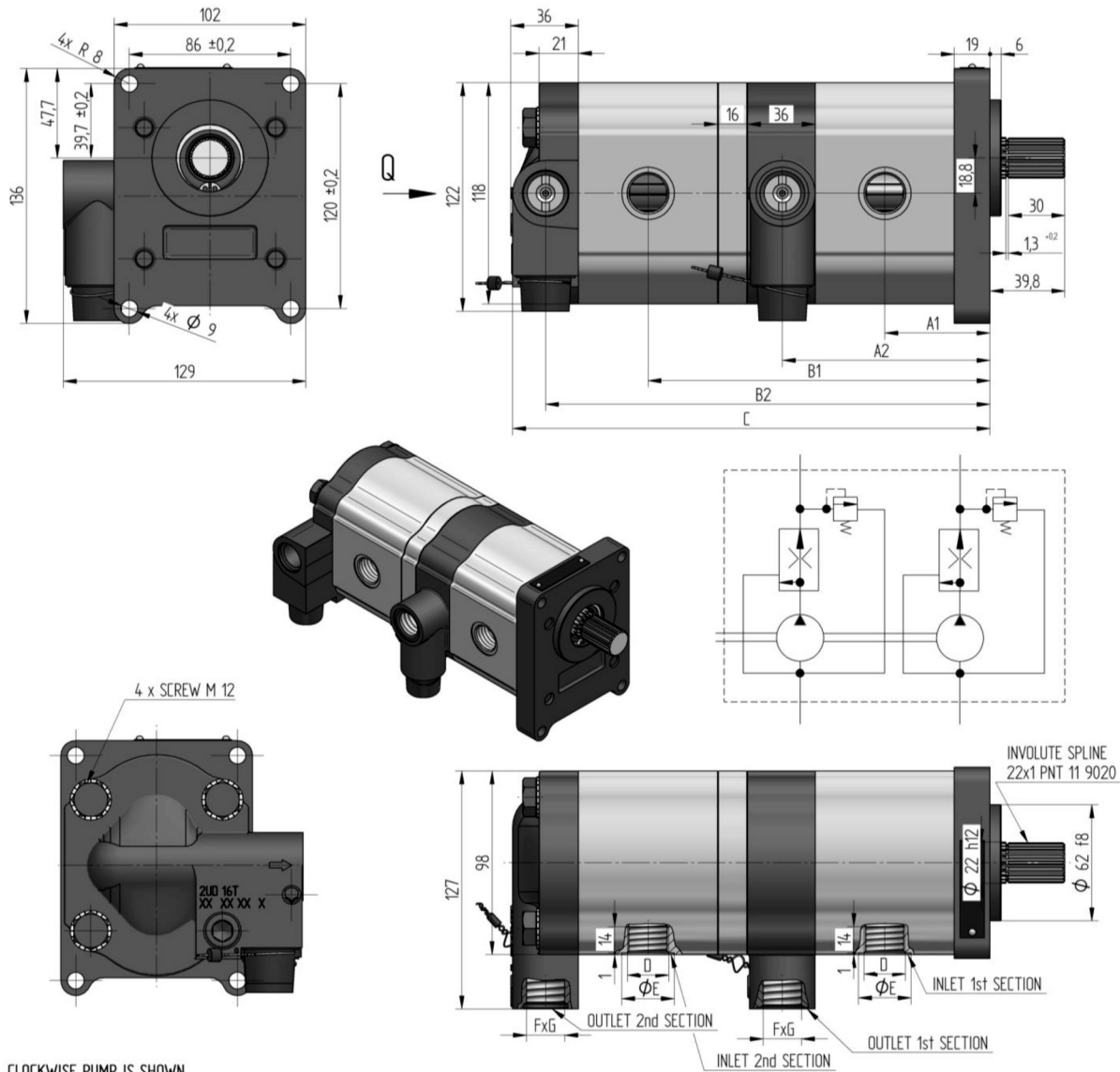

CLOCKWISE PUMP IS SHOWN

Order key	purch. code	direct. of rot.	displacement [cm <sup>3</sup> /1]	speed MIN. [min <sup>-1</sup> ]	speed MAX. [min <sup>-1</sup> ]	dimension								
						A1 [mm]	A2 [mm]	B1 [mm]	B2 [mm]	C [mm]	D [mm]	E [mm]	F [mm]	G [mm]
UD-31/31R-R09D12-SM07M07/M07M07-N		R	31	450	2800	65.50	129.5	210.50	274.5	293.0	M22x1.5	28	M22x1.5	28
UD-31/31L-R09D12-SM07M07/M07M07-N		L												
UD-28/28R-R09D12-SM07M07/M07M07-N		R	28	450	3000	63.25	125.0	203.75	265.5	284.0	M22x1.5	28	M22x1.5	28
UD-28/28L-R09D12-SM07M07/M07M07-N		L												
UD-25/25R-R09D12-SM07M07/M07M07-N		R	25	450	3200	61.50	121.5	198.50	258.5	277.0	M22x1.5	28	M22x1.5	28
UD-25/25L-R09D12-SM07M07/M07M07-N		L												
UD-20/20R-R09D12-SM07M07/M07M07-N		R	20	450	3200	58.50	115.5	189.50	246.5	265.0	M22x1.5	28	M22x1.5	28
UD-20/20L-R09D12-SM07M07/M07M07-N		L												
UD-16/16R-R09D12-SM07M07/M07M07-N	183 9645	R	16	450	3200	56.00	110.5	182.00	236.5	255.0	M22x1.5	28	M22x1.5	28
UD-16/16L-R09D12-SM07M07/M07M07-N		L												
UD-12.5/12.5R-R09D12-SM07M07/M07M07-N		R	12.5	450	3200	53.50	105.5	174.50	226.5	245.0	M22x1.5	28	M22x1.5	28
UD-12.5/12.5L-R09D12-SM07M07/M07M07-N		L												
UD-10/10R-R09D12-SM07M07/M07M07-N		R	10	450	3200	52.25	103.0	170.75	221.5	240.0	M22x1.5	28	M22x1.5	28
UD-10/10L-R09D12-SM07M07/M07M07-N		L												
UD-8/8R-R09D12-SM07M07/M07M07-N		R	8	600	3200	51.00	100.5	167.00	216.5	265.0	M22x1.5	28	M22x1.5	28
UD-8/8L-R09D12-SM07M07/M07M07-N		L												

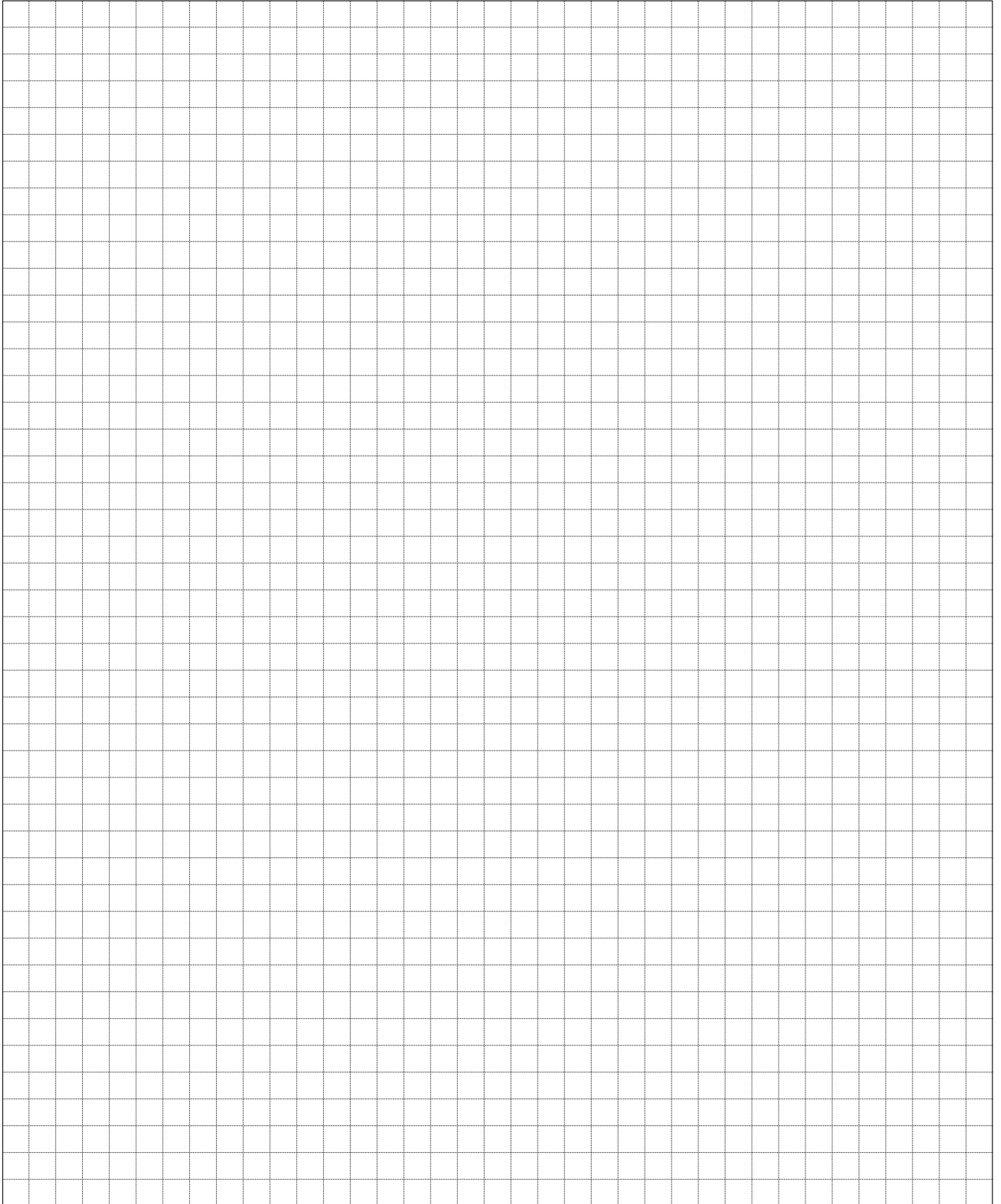

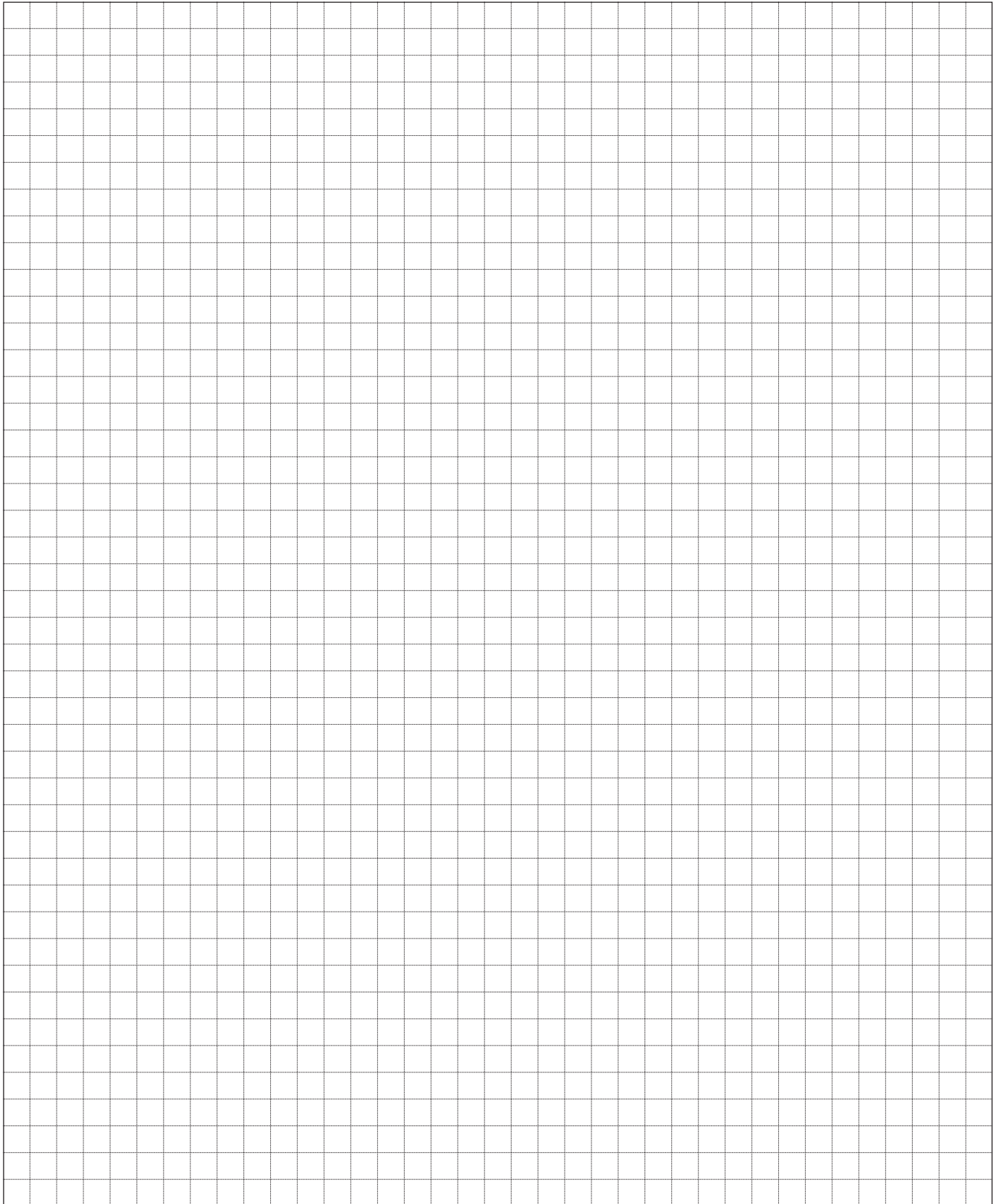

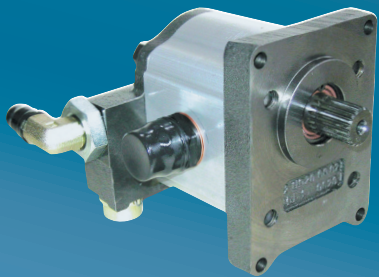
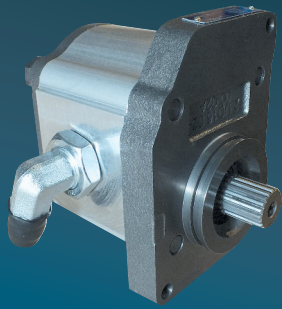

**jihostroj**  
AERO TECHNOLOGY & HYDRAULICS

**JIHOSTROJ a.s.**  
Budějovická 148  
CZ 382 32 Velešín  
Czech Republic  
tel.: +420 380 340 511  
fax: +420 380 340 612  
e-mail: mailbox@jihostroj.cz  
http: //www.jihostroj.com

GPS 48°49'51.748" N 14°27'40.770" E

