

Displacement from 4 to 31 ccm
Pressure up to 270 bar
Speed from 500 to 4000 RPM

GEAR MOTORS
TM3

TABLE OF CONTENTS

DESCRIPTION.....	2
BASIC PARTS OF MOTOR.....	2
PARAMETER TABLE.....	3
FORMULAS USED FOR CALCULATION.....	4
MOTOR EFFICIENCIES.....	4
WORKING LIQUID.....	5
PRESSURE LOAD.....	5
DIRECTION OF ROTATION.....	6
REVERSIBLE DESIGN.....	6
MOTOR WITH A FRONT-END BEARING.....	6
TM3 FLOW RATE AND POWER CURVES.....	7
ORDER KEY.....	10
COMBINATIONS OF FLANGES AND SHAFTS.....	11
FLANGE DESIGN.....	12
DRIVE SHAFTS.....	13
LIQUID INLET AND OUTLET CONNECTION.....	16
CATALOGUE SHETS OF TM3 SERIES BASIC DESIGNS.....	17
NOTES.....	25

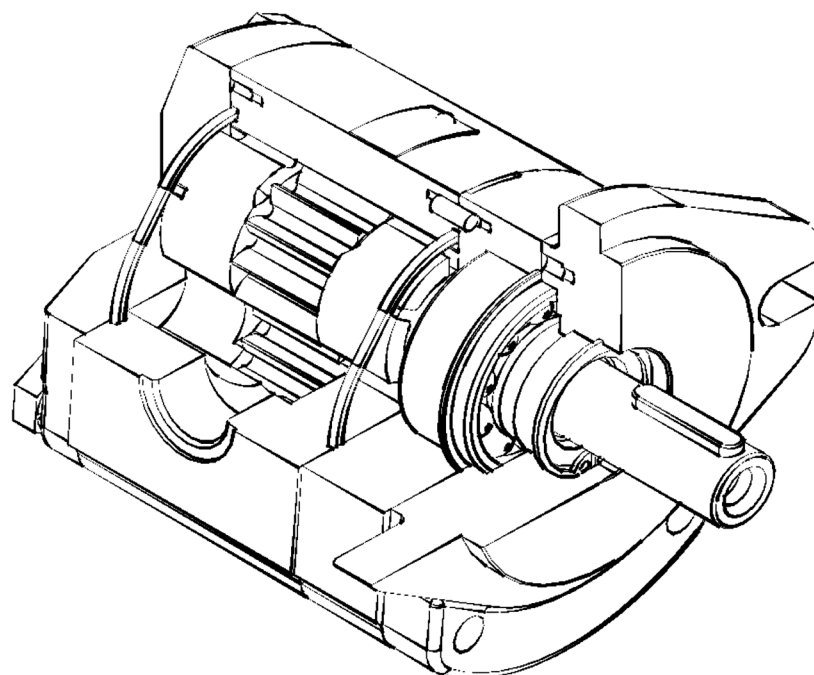

DESCRIPTION

- Gear motors are used for transformation of liquid pressure head in mechanical energy. TM3 series motors with external teeth are due to their simple construction, compact dimensions and a wide range of types applicable in modern hydraulic systems, handling equipment as well as mobile hydraulic systems. Flange types used as well as the form of working liquid inlet and outlet comply with all worldwide standards. The TM3 series covers the range of displacements from 4 to 31 cm³/rev.
- The basic version consists of several parts. The body is made of a heavy duty aluminium alloy, engine cover and flange of grey iron or eventually aluminium alloy, and gear wheels of heavy duty steel. Axle pins with a high surface duality are imbedded in sliding sleeves, continuously lubricated and cooled by a stream of working liquid. The axial pump balancing is performed using sliding aluminium alloy bearing sleeves in which a shape sealing of balancing surface is located in grooves. TM3 series motors can be delivered in one-way design as clockwise or anti-clockwise rotating engines; they are also available in reversible version.

BASIC PARTS OF MOTOR

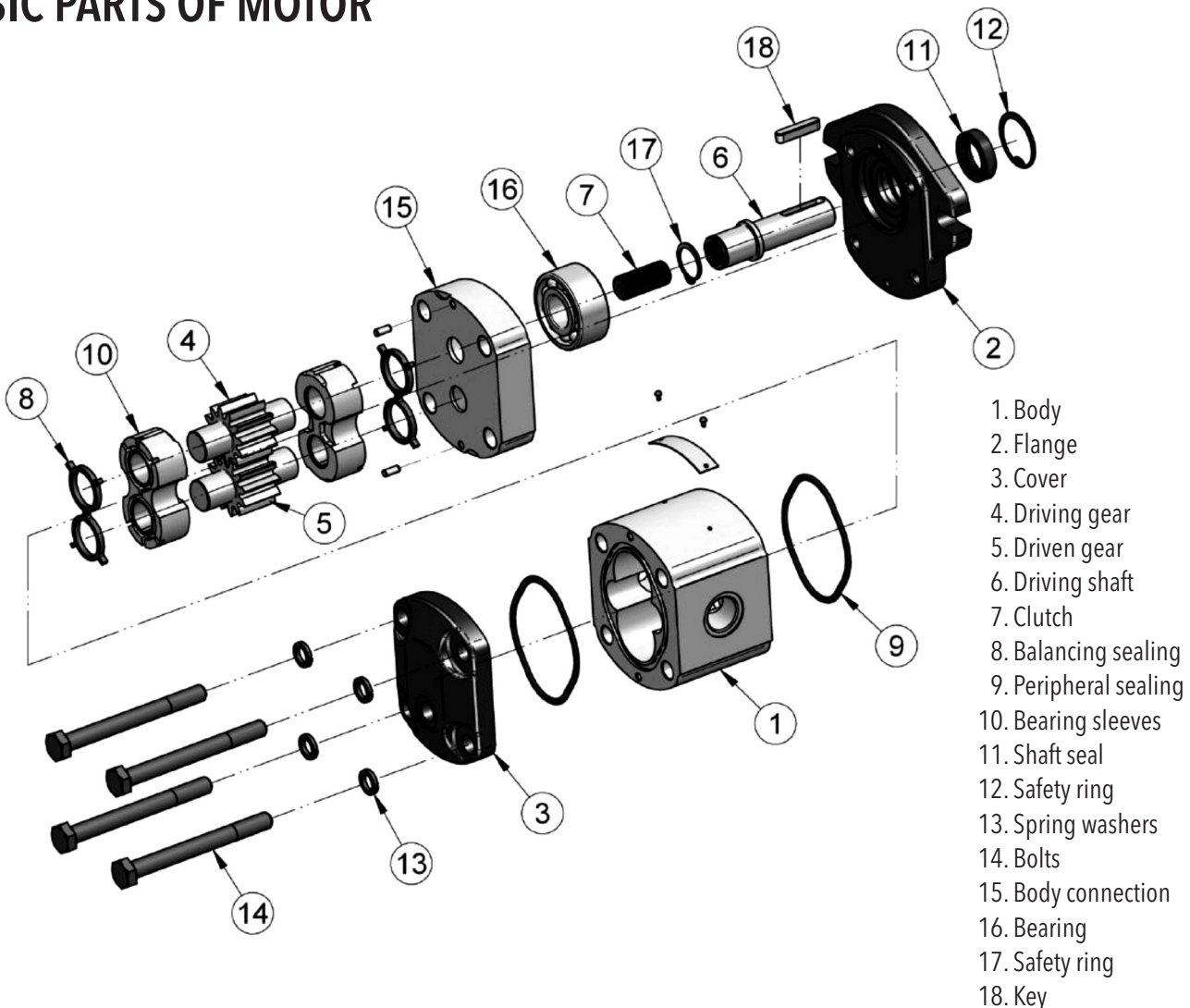

PARAMETER TABLE

One direction motors

Nominal Size Parameters		Sym.	Unit	TM3 4	TM3 6	TM3 8	TM3 12	TM3 16	TM3 20	TM3 25	TM3 31
Actual displacement		V_g	[cm ³]	4.03	6.02	8.05	12.08	16.10	20.12	25.16	31.21
Rotation speed	nominal	n_n	[min ⁻¹]	1500	1500	1500	1500	1500	1500	1500	1500
	minimum	n_{min}	[min ⁻¹]	500	500	500	500	500	500	500	500
	maximum	n_{max}	[min ⁻¹]	4000	4000	3600	3600	3200	3200	2800	2200
Pressure at outlet	minimum	p_{1min}	[bar]	-0.3	-0.3	-0.3	-0.3	-0.3	-0.3	-0.3	-0.3
	maximum	p_{1max}	[bar]	0.5	0.5	0.5	0.5	0.5	0.5	0.5	0.5
Pressure at inlet	max. continuous	p_{2n}	[bar]	270	270	270	250	250	200	180	150
	maximum	p_{2max}	[bar]	290	290	290	270	270	240	200	170
	peak	p_3	[bar]	310	310	310	290	290	260	220	190
Nominal input flow rate (max.) at n_n and p_{2n}		Q_n	[dm ³ .min ⁻¹]	7.06	10.59	13.64	20.45	26.67	33.33	41.67	51.67
Maximum input flow rate at n_{max} and p_{2max}		Q_{max}	[dm ³ .min ⁻¹]	17.02	25.53	30.64	45.96	54.47	68.09	74.47	72.55
Nominal output power (min.) at n_n and p_{2n}		P_n	[kW]	2.19	3.28	4.47	6.21	8.46	8.46	9.52	9.83
Maximum output power at n_{max} and p_{2max}		P_{max}	[kW]	6.82	10.23	12.28	17.15	20.32	22.58	20.58	17.04
Nominal Torque at n_n and p_{2n}		M	[Nm]	15.47	23.20	30.94	42.97	57.30	57.30	64.46	66.61
Weight		m	[kg]	2.60	2.65	2.75	2.95	3.10	3.35	3.50	3.80

Reversible motors

Nominal Size Parameters		Sym.	Unit	TM3 4	TM3 6	TM3 8	TM3 12	TM3 16	TM3 20	TM3 25	TM3 31
Actual displacement		V_g	[cm ³]	4.03	6.02	8.05	12.08	16.10	20.12	25.16	31.21
Rotation speed	nominal	n_n	[min ⁻¹]	1500	1500	1500	1500	1500	1500	1500	1500
	minimum	n_{min}	[min ⁻¹]	500	500	500	500	500	500	500	500
	maximum	n_{max}	[min ⁻¹]	4000	4000	3600	3600	3200	3200	2800	2200
Pressure at outlet	minimum	p_{1min}	[bar]	-0.3	-0.3	-0.3	-0.3	-0.3	-0.3	-0.3	-0.3
	maximum	p_{1max}	[bar]	210	210	210	210	200	160	140	100
Pressure at inlet	max. continuous	p_{2n}	[bar]	270	270	270	250	250	200	180	150
	maximum	p_{2max}	[bar]	290	290	290	270	270	240	200	170
	peak	p_3	[bar]	310	310	310	290	290	260	220	190
Nominal input flow rate (max.) at n_n and p_{2n}		Q_n	[dm ³ .min ⁻¹]	7.06	10.59	13.64	20.45	26.67	33.33	41.67	51.67
Maximum input flow rate at n_{max} and p_{2max}		Q_{max}	[dm ³ .min ⁻¹]	17.02	25.53	30.64	45.96	54.47	68.09	74.47	72.55
Nominal output power (min.) at n_n and p_{2n}		P_n	[kW]	2.19	3.28	4.47	6.21	8.46	8.46	9.52	9.83
Maximum output power at n_{max} and p_{2max}		P_{max}	[kW]	6.82	10.23	12.28	17.15	20.32	22.58	20.58	17.04
Nominal Torque at n_n and p_{2n}		M	[Nm]	15.47	23.20	30.94	42.97	57.30	57.30	64.46	66.61
Weight		m	[kg]	2.60	2.65	2.75	2.95	3.10	3.35	3.50	3.80

FORMULAS USED FOR CALCULATION

Flow rate
 Q

$$Q = \frac{V_g \cdot n}{1000} \cdot \eta_v \quad [\text{dm}^3 \cdot \text{min}^{-1}]$$

V_g [cm³] pump displacement
 n [min⁻¹] rotation speed
 η_v [-] volumetric efficiency

Displacement
 V_g

$$V_g = \frac{Q \cdot 1000}{n \cdot \eta_v} \quad [\text{cm}^3]$$

Torque
 M_k

$$M_k = \frac{V_g \cdot p}{20 \cdot \pi \cdot \eta_m} \quad [\text{Nm}]$$

p [bar] required pressure at outlet
 η_m [-] mechanical efficiency

Input power
 P

$$P = \frac{V_g \cdot n \cdot p}{600 \cdot 1000 \cdot \eta_t} \quad [\text{kW}]$$

η_t [-] total efficiency

PUMP EFFICIENCIES

Volumetric efficiency
It determines the amount of flow losses. Its value is $\eta_v = 0,92 \div 0,98$ (depending on rotation speed, viscosity of working liquid and outlet pressure). It can be expressed as follows:

η_v

$$\eta_v = \frac{Q_{act.}}{Q_{theor}} \quad [-]$$

$Q_{act.}$ [dm³ · min⁻¹] actual flow rate
 Q_{theor} [dm³ · min⁻¹] theoretical flow rate

Mechanical efficiency
It determines mechanical losses. Its value is about $\eta_m = 0,85$. It can be expressed as follows:

η_m

$$\eta_m = \frac{M_{theor}}{M_{act.}} \quad [-]$$

$M_{act.}$ [Nm] actual torque
 M_{theor} [Nm] theoretical torque

Total efficiency
 t is defined as product of η_n and η_m and determines difference between theoretical and actual required input power:

η_t

$$\eta_t = \eta_v \cdot \eta_m = \frac{P_{theor}}{P_{act.}} \quad [-]$$

$P_{act.}$ [kW] actual input power
 P_{theor} [kW] theoretical input power

WORKING LIQUID

- Mineral oils for hydraulic drives
- Hydraulic liquids based on plant oils suitable for hydraulic drives

Liquid temperature

- $t = -20 \div +80$ [°C]
when used with FKM (Viton) seal up to 120 [°C]

Cinematic viscosity

- Recommended (during continuous operation): $\nu = 20 \div 80 \cdot 10^{-6}$ [m² · s⁻¹]
- Maximum (cold starting, at viscosity >1000, operating pressure <10 bar is permissible, speed <1500·min⁻¹): $\nu = 1200 \cdot 10^{-6}$ [m² · s⁻¹]
- Minimum (operating mode at $10 \cdot 10^{-6}$ up $20 \cdot 10^{-6}$ should be consulted with manufacturer): $\nu = 10 \cdot 10^{-6}$ [m² · s⁻¹]

Filtration coefficient β_{α}

$\beta_{25\ 75} \geq$ (for pressure $p_2 < 200$ bar)
 $\beta_{10\ 75} \geq$ (for pressure $p_2 > 200$ bar)

Liquid contamination class according to ISO 4406

21/18/15 (for pressure $p_2 < 200$ bar)
20/17/14 (for pressure $p_2 > 200$ bar)

Liquid contamination class according to NAS 1638

10 (for pressure $p_2 < 200$ bar)
8 (for pressure $p_2 > 200$ bar)

PRESSURE LOAD

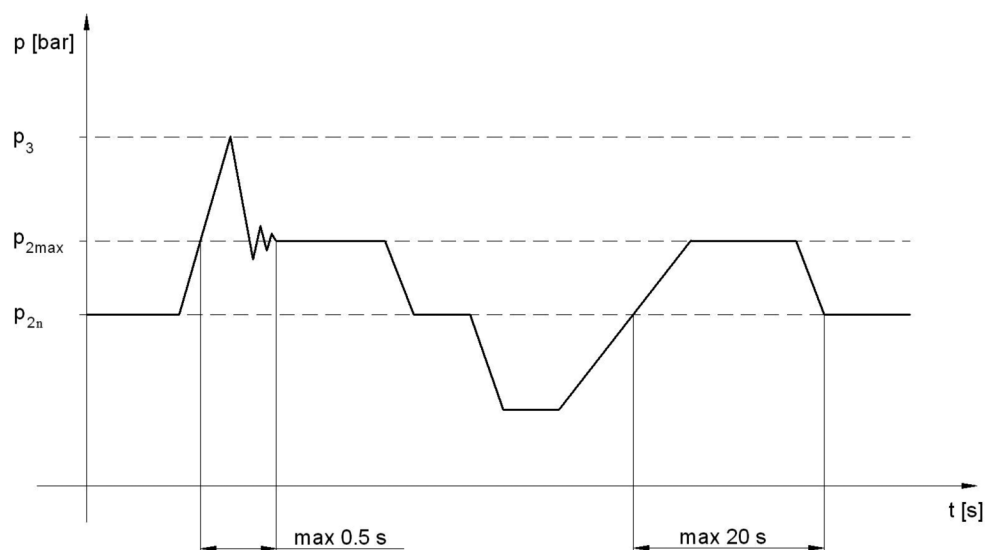

- p_{2n} max. contin. pressure** Max. working pressure, at which the pump can be operated without time limitation.
- p_{2max} max. pressure** Maximum pressure permissible for a short time, max. 20s.
- p_3 peak pressure** Short-time pressure (fractions of a second) arising in case of a sudden change of the operating mode; any excess of this pressure during operation is impermissible.

DIRECTION OF ROTATION

- Determine direction of rotation by looking at the drive shaft. The motor can only be used in the specified direction of rotation.

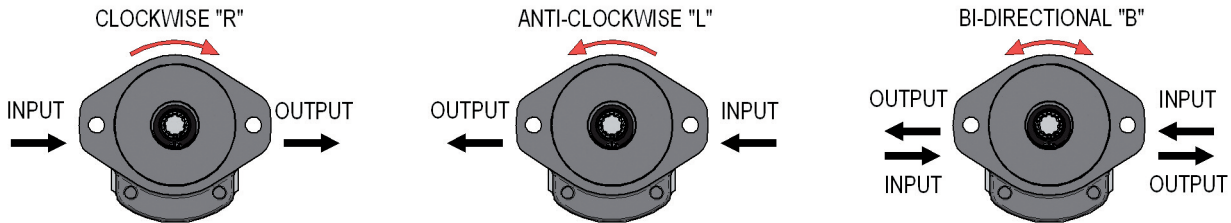

REVERSIBLE DESIGN

- The motors with the possibility of bidirectional rotation have a different internal arrangement requiring drainage. Two types are used - internal and external. The internal drainage is always interconnected with the outlet by means of valves. The external drainage is solved by an orifice located in the cover opposite the driven gear.

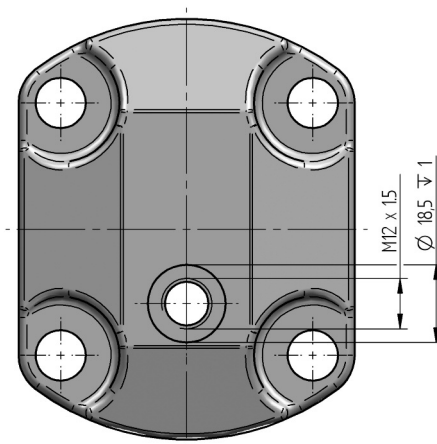

MOTOR WITH A FRONT-END BEARING

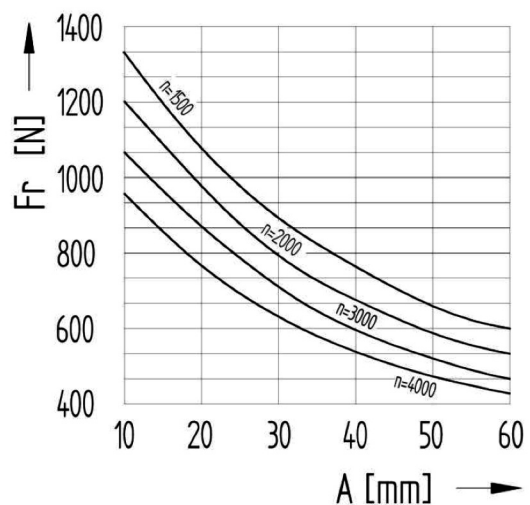
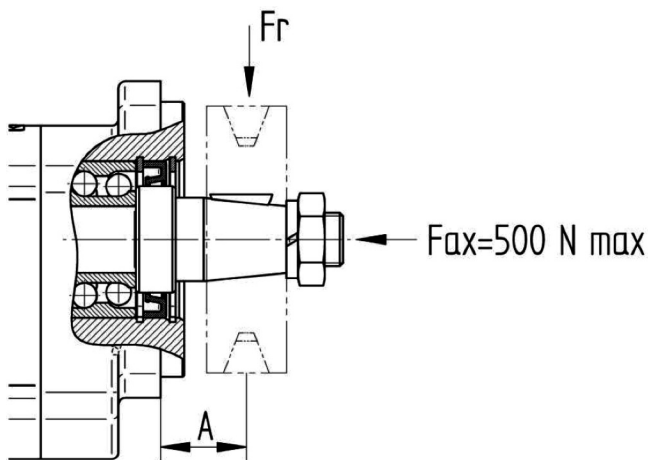

A driven device must not generate an axial or a radial load of the motor shaft, unless this is exclusively permitted for the motor with a front-end bearing.

TM3 FLOW RATE AND POWER CURVES

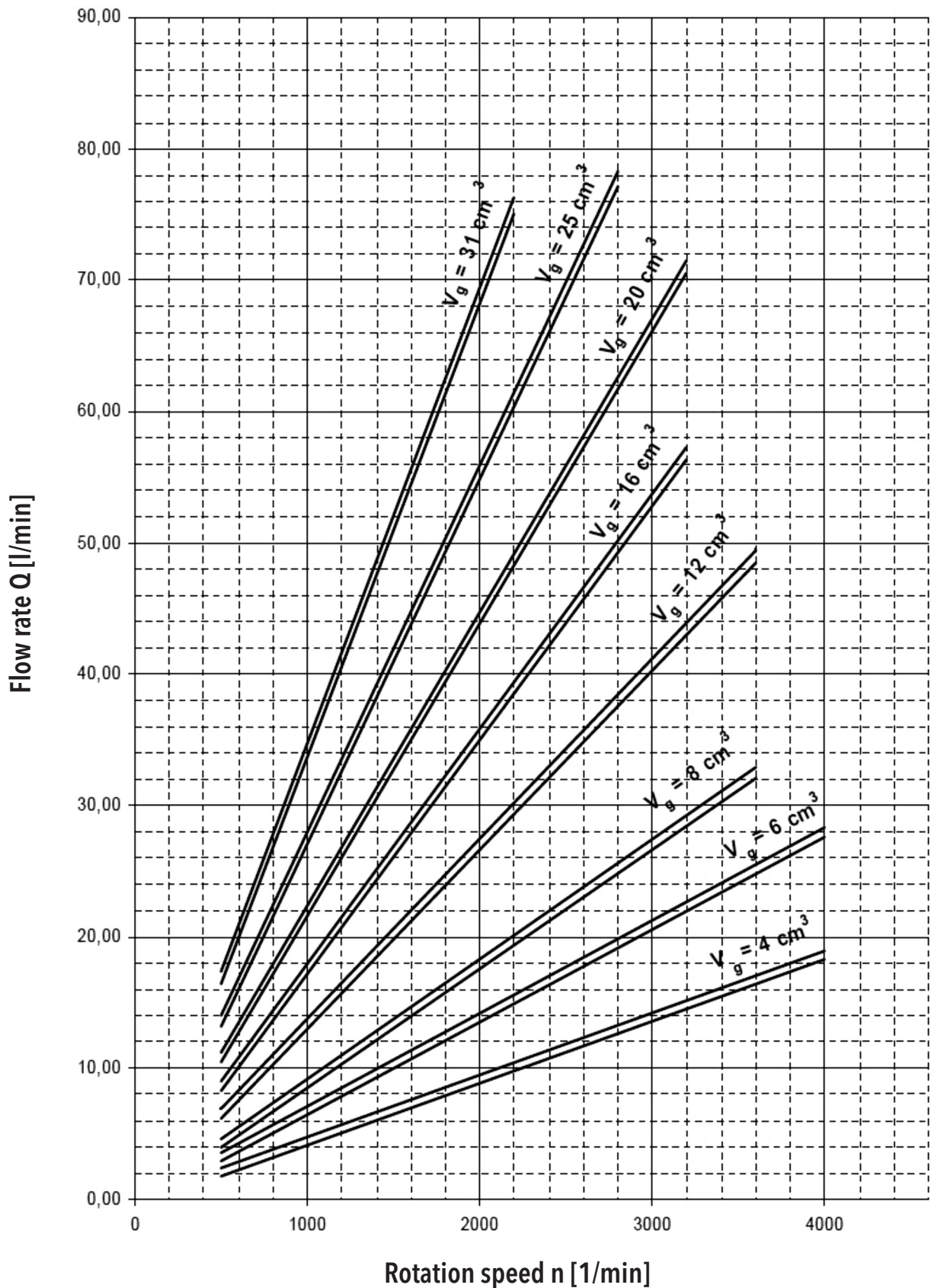

Above curves apply to ISO Vg 46 oil at temperature $t = 45^\circ C$.

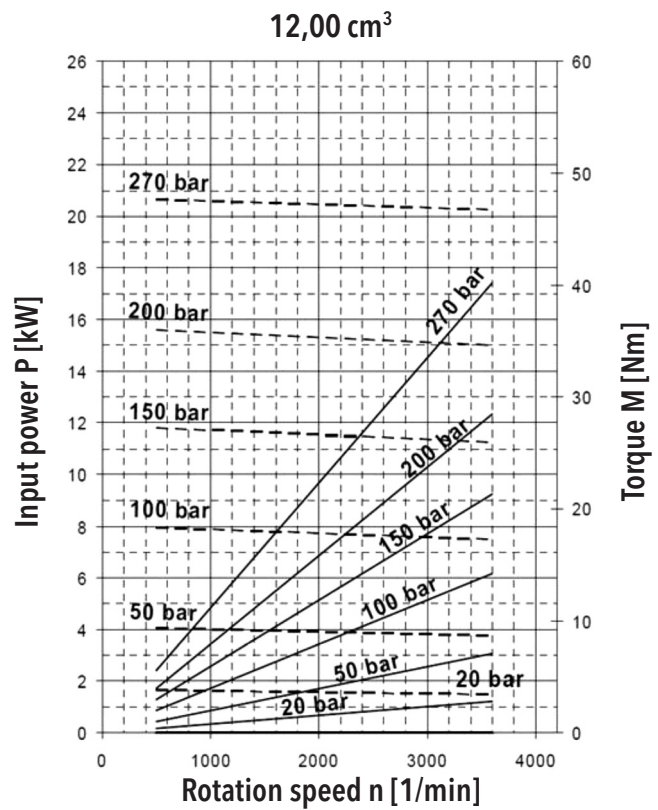
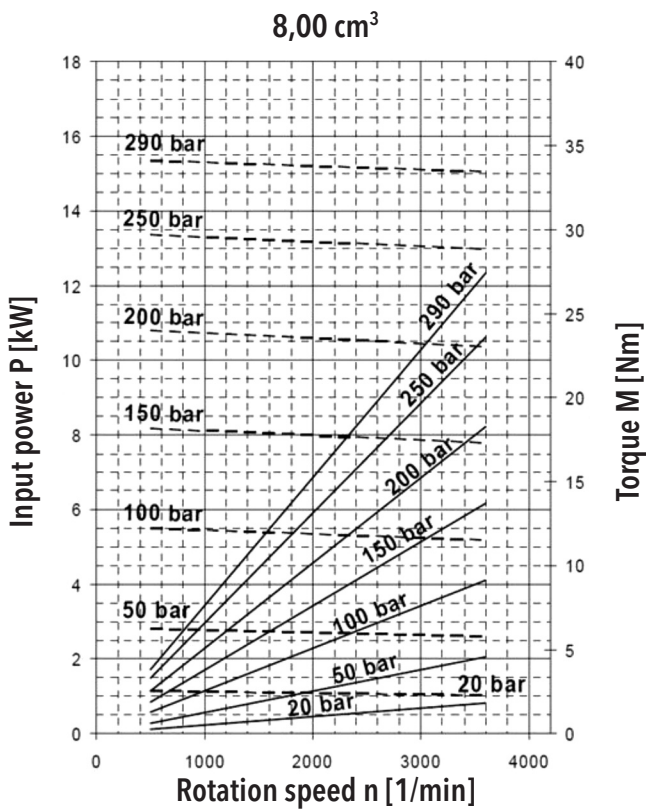
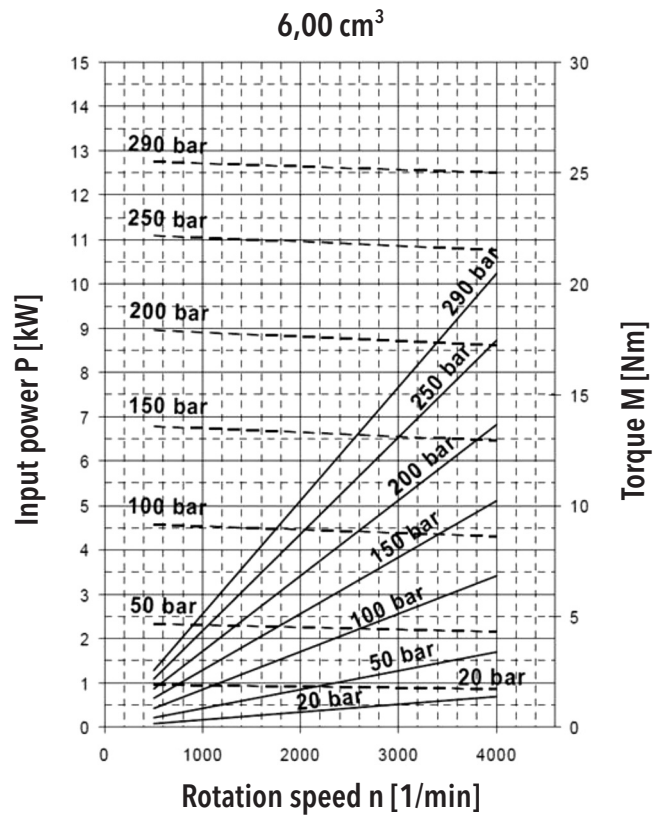
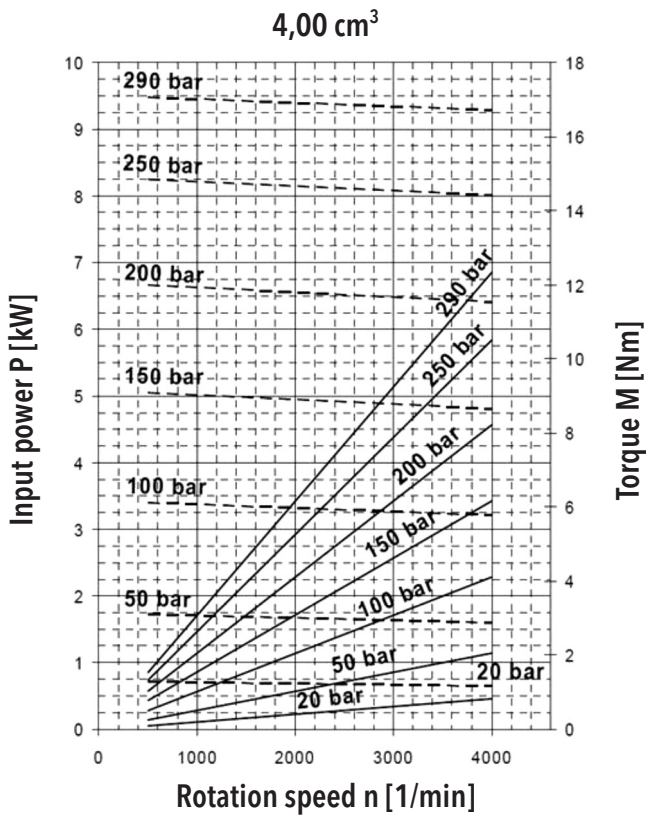

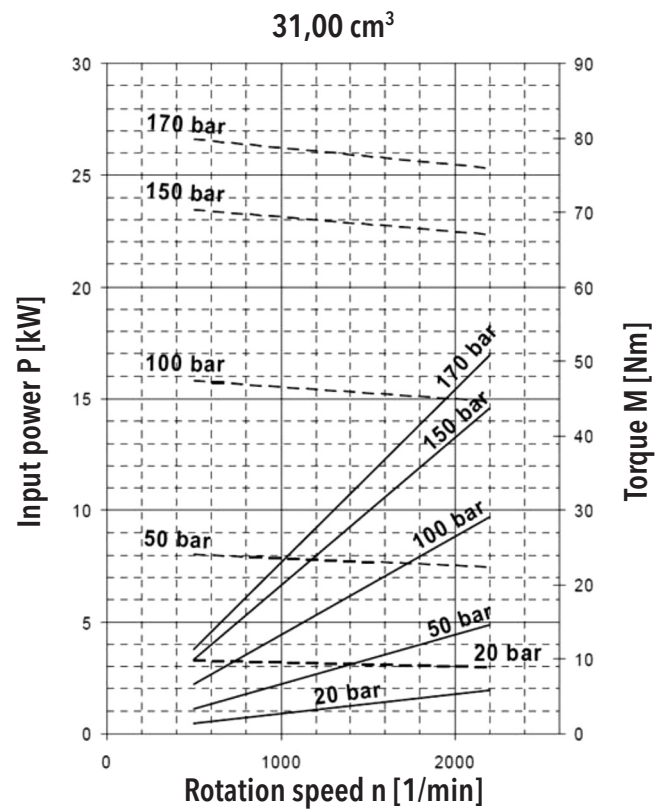
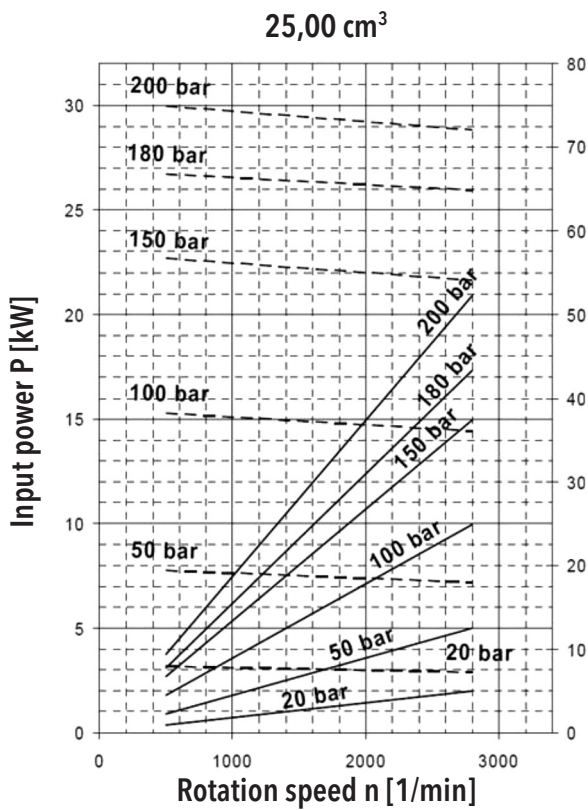
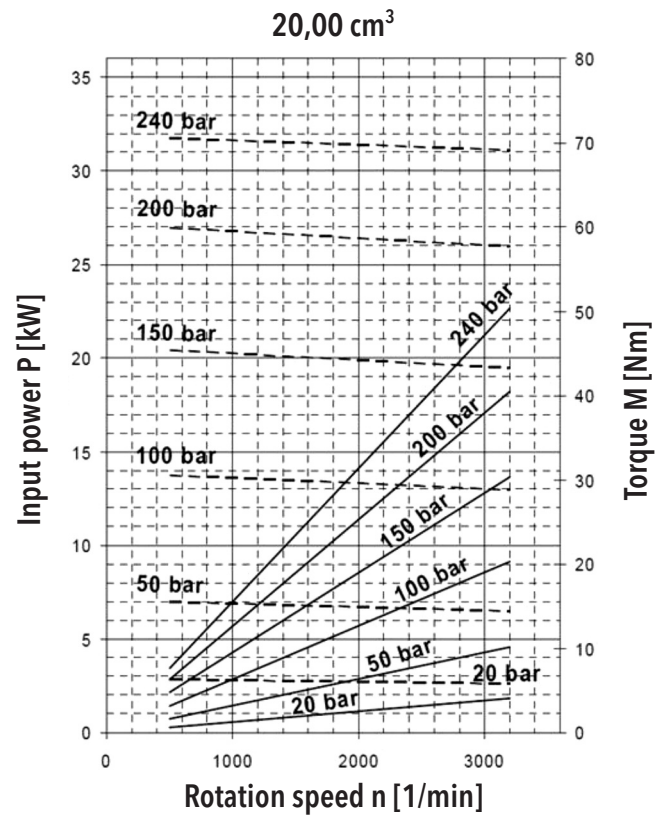
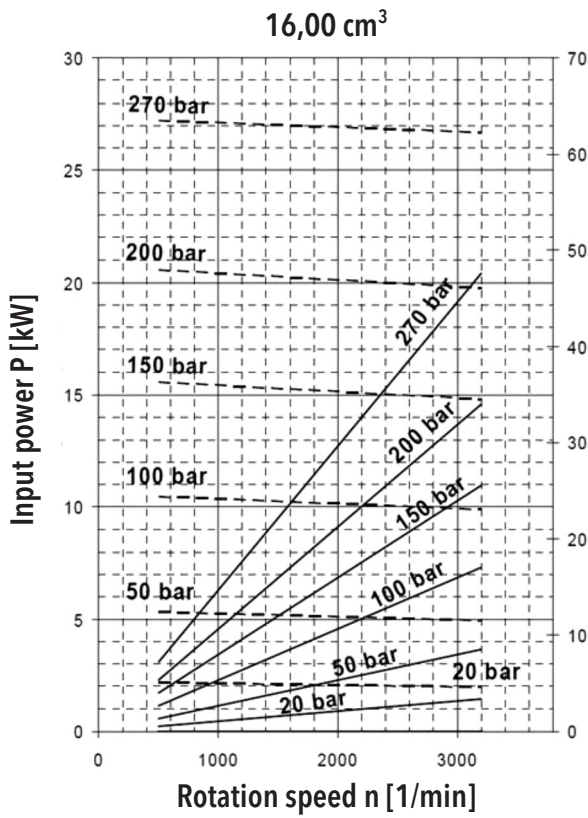

ORDER KEY

TM3 - 16 R - S02 D04 - S G04 G03 - V . 001

Code	Type
TM3	TM3 Series Gear Motor

Code	Displacement [cm ³]
4	4,03
6	6,02
8	8,05
12	12,08
16	16,10
20	20,12
25	25,16
31	31,21
XX	Other displacements on request

Code	Direction of rotation
R	Clockwise
L	Anti-clockwise
B	Bi-directional

Code	Flange design	
F02		Square flange, centre ring Ø80
R05		Square flange, centre ring Ø36,5
R06		Square flange, centre ring Ø80
R07		Square flange, centre ring Ø60
S02		SAE A
S03		SAE B
A07		Flange with trough-bolts, centre ring Ø50
A08		Flange with trough-bolts, centre ring Ø50
A09		Flange with trough-bolts, centre ring Ø52, with O-ring
A10		Flange with trough-bolts, centre ring Ø52, with O-ring
Z		Special desing

Code	Location of inlets and outlets	
S		Side (in the body)
R		Axial (in the cover)
C		Combination
S		Special desing

Code	Drive shaft desing	
C07		Taper 1:8 Key width 3
C08		Taper 1:8 Key width 3,2
C09		Taper 1:8 Key width 4
C10		Taper 1:5 Key width 3
D04		Spline SAE 9T 16/32 DP
D06		Spline SAE 11T l=32, 16/32 DP
D07		Spline SAE 11T l=38, 16/32 DP
D08		Spline ČSN 17x1,25
D09		Spline DIN 5482 B17x14
D10		Spline GOST 6033-80
D11		Spline 16x13x3,5
K07		Cross coupling
V09		Cylindric Ø5/8" Key 4x4
V11		Cylindric Ø15 Key 4x4
V12		Cylindric Ø3/4" Key 4,8x4,8
V13		Cylindric Ø20 Key 6x6
Z		Special desing

Code	Special arrangements
-	No special arrangements
001	With front-end bearing type 1
002	With front-end bearing type 2
003	Sealed section for multiple version
004	Without shaft seal
005	Inlet in body, outlet in cover
006	Inlet in cover, outlet in body
007	Inlet in body, outlet in flange
008	Inlet in flange, outlet in body
009	Drain M12x1,5 in cover
010	With from-end bearing type 3
011	Drain G 1/4 in cover
012	Internal drain
013	Variseal
014	Shaft seal - double lip

Code	Seal material	
N		NBR
V		FKM
H		HNBR

Code	Liquid inlet and outlet connection shape	
M05		Thread M 18x1,5
M09		Thread M 27x2
G03		Thread BSP G1/2
G04		Thread BSP G3/4
G05		Thread BSP G1"
U04		Thread 7/8-14 UNF-2B
U05		Thread 1-1/16-12 UN-2B
H05		Flanged fitting Ø15; Square 4xM6 Ø35
H06		Flanged fitting Ø20; Square 4xM6 Ø40
H07		Flanged fitting Ø13,5; Square 4xM6 Ø30
H08		Flanged fitting Ø20; Square 4xM8 Ø40
H10		Flanged fitting Ø26; Square 4xM8 Ø55
K01		Flanged fitting Ø13,5; Cross 4xM6 Ø30
K02		Flanged fitting Ø20; Cross 4xM8 Ø40
K07		Flanged fitting Ø14; Cross 4xM8 Ø38
K08		Flanged fitting Ø19; Cross 4xM8 Ø38
Z		Special desing

An example of designation for the TM3 clockwise motor with displacement of 16 cm³, SAE A flange; Spline SAE 9T; BSP side inlets in the body and FKM sealing, with front-end bearing: **TM3-16R-S02D04-SG04G03-V.001**

Note: In case of combination inlets, with the code „C” is respected following sequence of inlets and outlets:

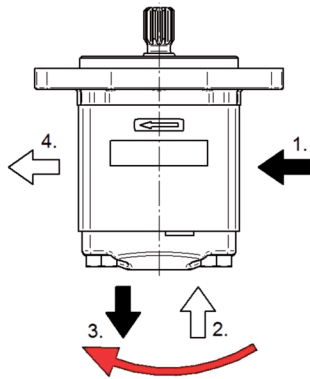

For clockwise and reverse gear motor,
in direction clockwise

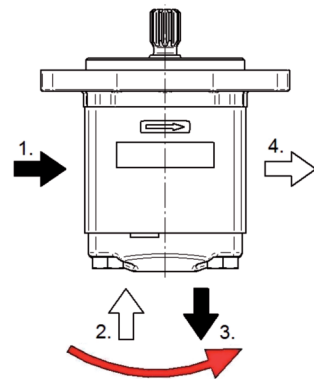

For anti-clockwise gear motor,
in direction anti-clockwise

For. ex....: TM3-12R-S02D04-CG03 G03 G04 G04 -N
1. 2. 3. 4.

COMBINATIONS OF FLANGES AND SHAFTS

		FLANGE DESIGN													
		F02	R05	R06	R07	S02	S03	A07	A08	A09	A10				
DRIVE SHAFT	C07		●												
	C08		●												
	C09		●												
	C10				●			●	●						
	D04						●	●							
	D06						●	●							
	D07						●	●							
	D08			●											
	D09				●				●	●					
	D10		●												
	D11					●									
	K05										●	●			
	V09						●	●							
	V11			●											
	V12						●	●							
V13		●													

FLANGES DESIGN

F02:

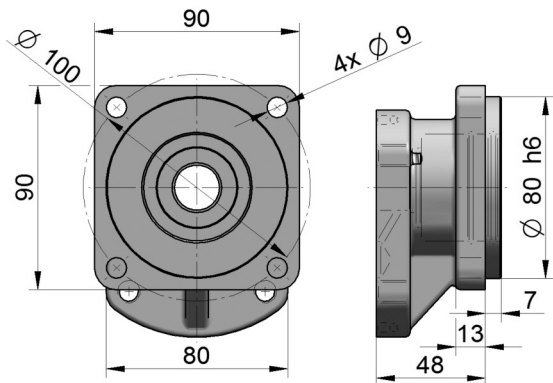

R05:

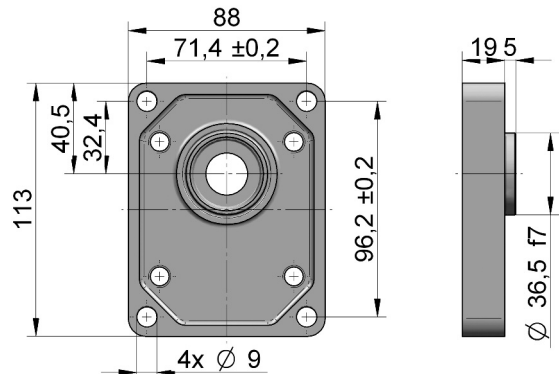

R06:

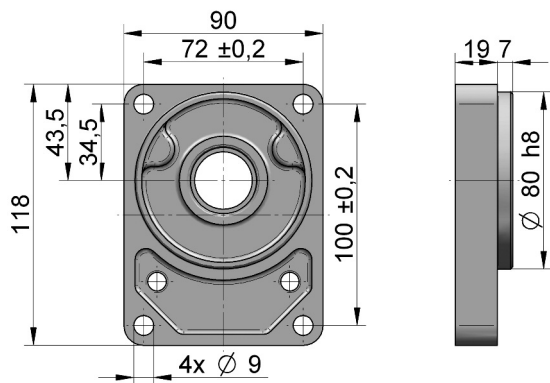

R07:

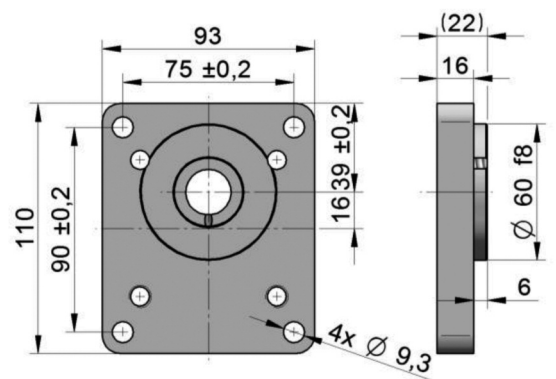

S02:

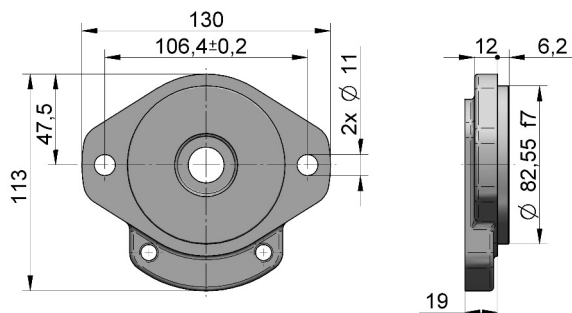

S03:

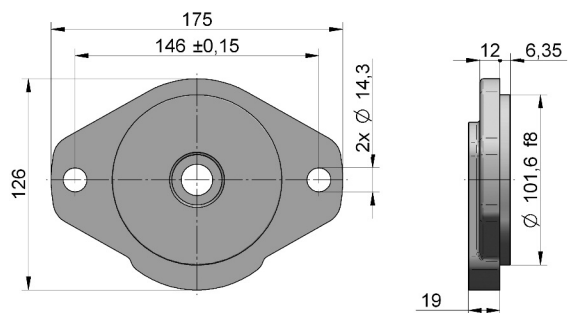

A07:

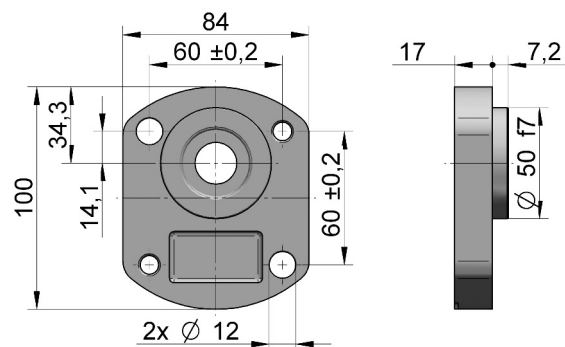

A08:

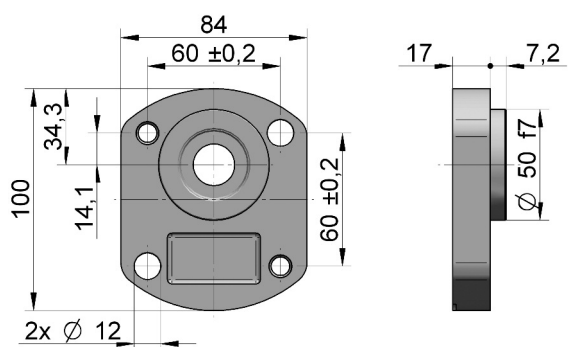

A09:

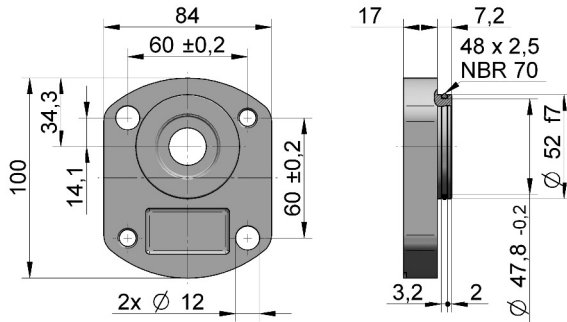

A10:

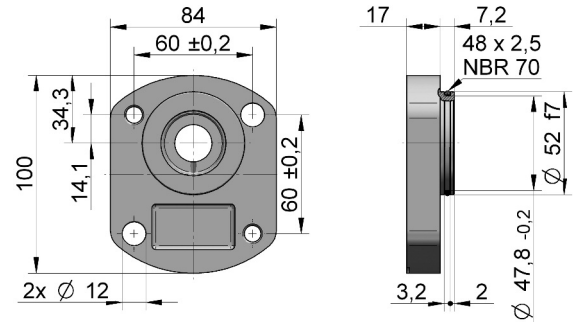

DRIVE SHAFT

Note: maximum allowed torque on a drive shaft is 100 Nm.

C07:

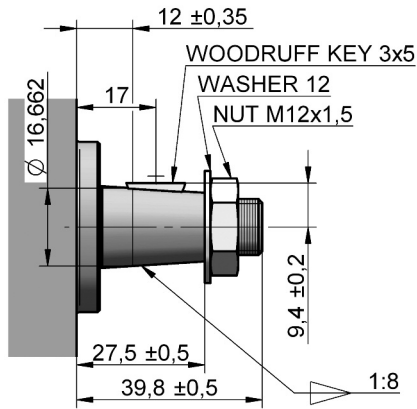

C08:

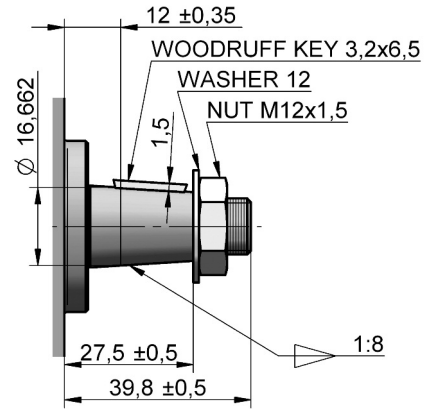

C09:

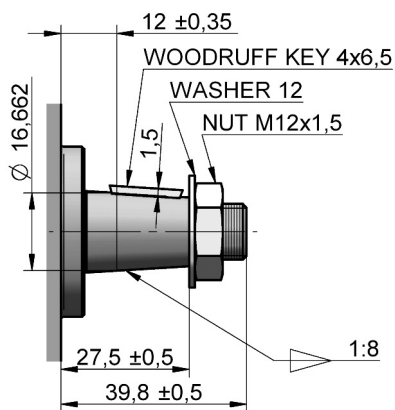

C10:

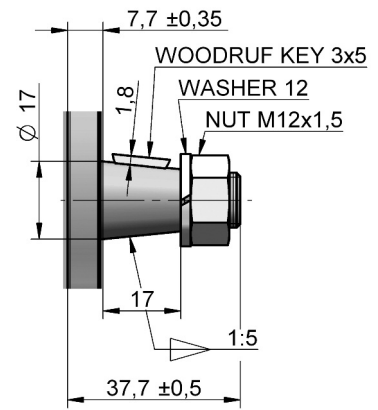

D04:

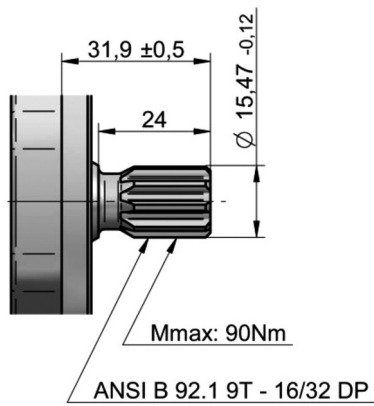

D06:

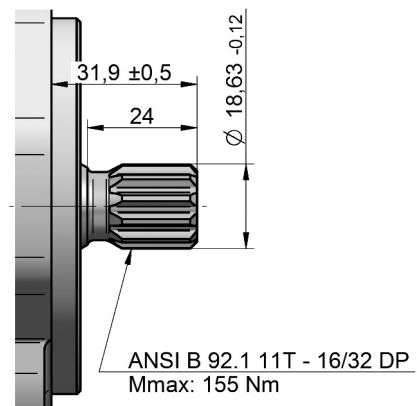

D07:

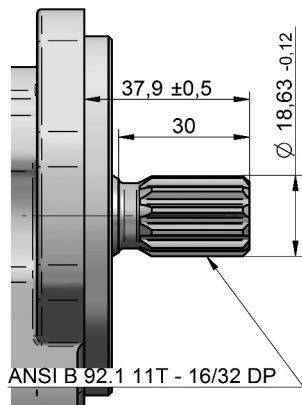

D08:

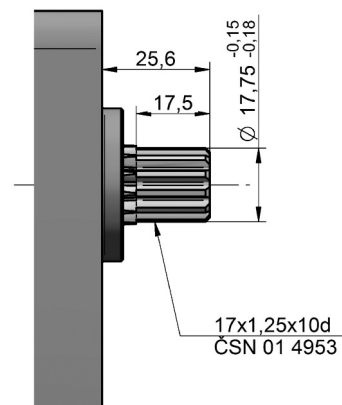

D09:

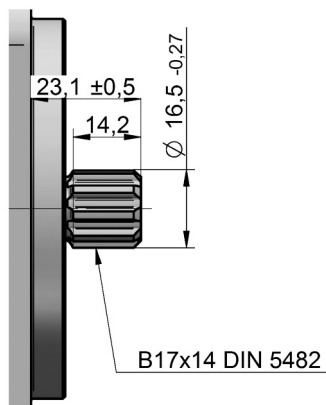

D10:

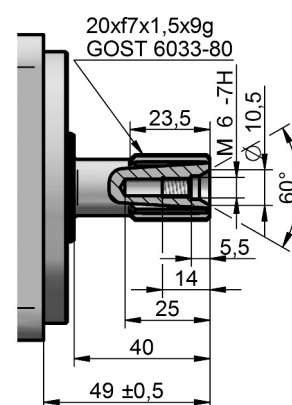

D11:

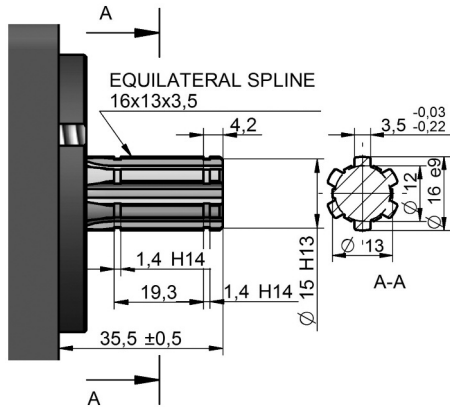

K07:

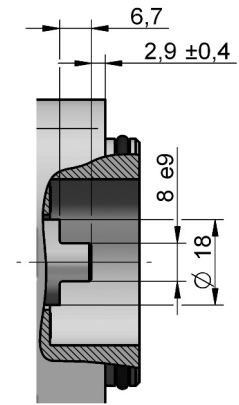

V09:

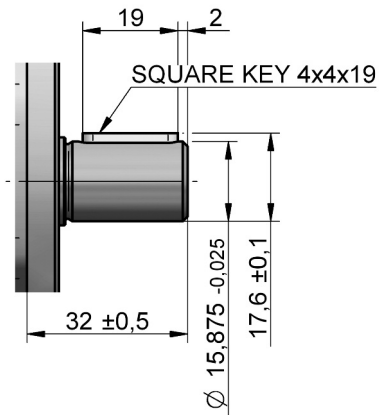

V11:

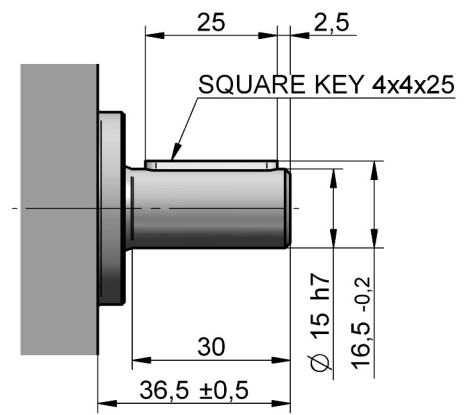

V12:

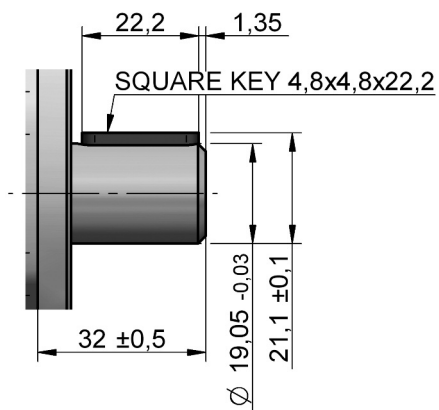

V13:

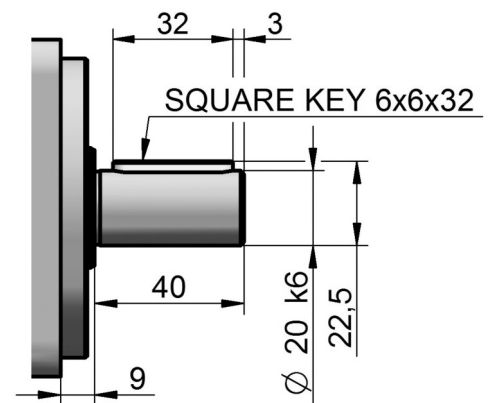

LIQUID INLET AND OUTLET CONNECTION

Metric thread according to ISO 6149

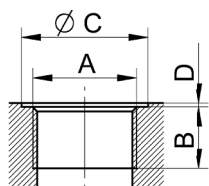

Displacement [cm ³]	kód	Inlet				kód	Outlet			
		A	B	C	D		A	B	C	D
all	M09	M 27x2	16	33	1	M05	M 18x1,5	14	24	1

BSPP pipe thread according to ISO 228 - 1

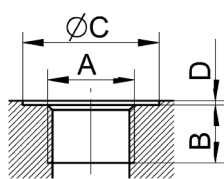

Displacement [cm ³]	Code	Inlet				Code	Outlet			
		A	B	C	D		A	B	C	D
to 10	G03	G 1/2"	14	33	1	G03	G 1/2"	14	33	1
10 - 25	G04	G 3/4"	16	39	1	G03	G 1/2"	14	33	1
above 25	G05	G 1"	18	45	1	G04	G 3/4"	16	39	1

UNF thread according to SAE

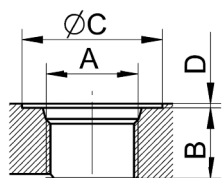

Displacement [cm ³]	Code	Inlet				Code	Outlet			
		A	B	C	D		A	B	C	D
to 10	U04	7/8-14 UNF-2B	17	34	1	U04	7/8-14 UNF-2B	17	34	1
11 - 31	U05	1-1/16-12 UNF-2B	19	41	1	U04	7/8-14 UNF-2B	17	34	1

Flanged fittings according to DIN 8901/8902

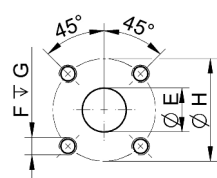

Displacement [cm ³]	Code	Inlet				Code	Outlet			
		E	F	G	H		E	F	G	H
all	H06	20	M6	13	40	H05	15	M6	13	35
all	H10	25	M8	13	55	H05	15	M6	13	35

Flanged fittings - „square”

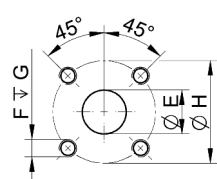

Displacement [cm ³]	Code	Inlet				Code	Outlet			
		E	F	G	H		E	F	G	H
all	H08	20	M8	13	40	H07	13.5	M6	13	30

Flanged fittings - „cross”

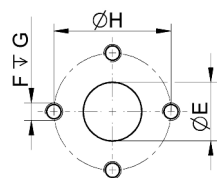

Displacement [cm ³]	Code	Inlet				Code	Outlet			
		E	F	G	H		E	F	G	H
all	K02	20	M8	13	40	K01	13.5	M6	13	30
to 10	K07	14	M8	13	38	K07	14.0	M8	13	38
above 10	K08	19	M8	13	38	K07	14.0	M8	13	38

Drain

Displacement [cm ³]	Code	Outlet			
		A	B	C	D
all	M02	M 12x1,5	12	20	1
	G01	G 1/4	12	45	1
	U01	7/16-20 UNF-2B	13	21	1
	U02	9/16-18 UNF-2B	14	25	1

CATALOGUE SHETS OF TM3 SERIES BASIC DESIGNS

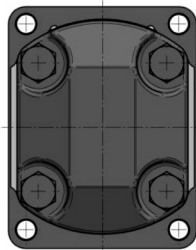
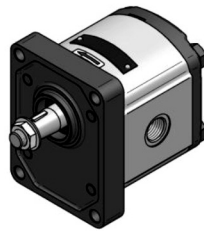
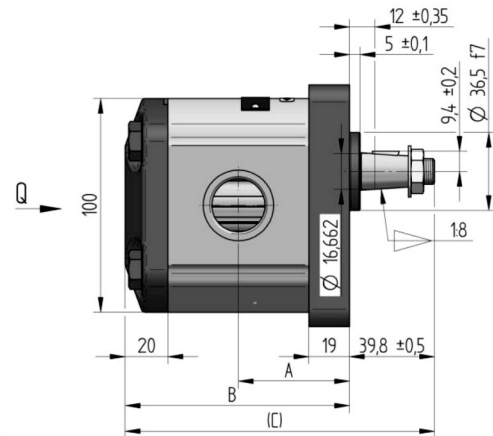
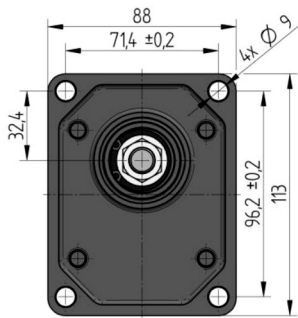

Q

THE ANTI-CLOCKWISE MOTOR IS DRAWN

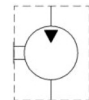
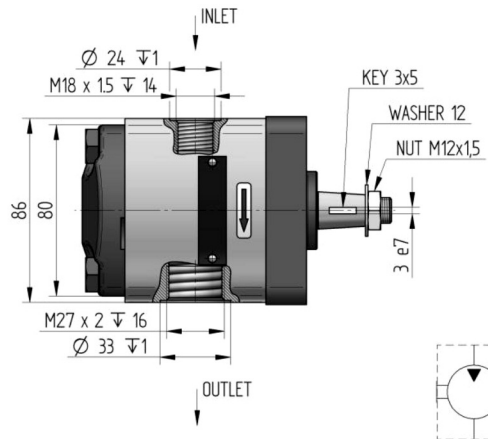

Order key	purch. code	direct. of rot.	displacement [cm ³ /1]	nom. press. [bar]	speed MIN. [min ⁻¹]	speed MAX. [min ⁻¹]	A [mm]	dimension B [mm]	C [mm]
TM3-31L- R05C07-SM09M05-N		L	31	150	500	2 200	63.7	128.5	168.3
TM3-31R- R05C07-SM09M05-N		R							
TM3-25L- R05C07-SM09M05-N		L	25	200	500	2 800	59.0	119.1	158.9
TM3-25R- R05C07-SM09M05-N		R							
TM3-20L- R05C07-SM09M05-N		L	20	240	500	3 200	55.0	111.2	151.0
TM3-20R- R05C07-SM09M05-N		R							
TM3-16L- R05C07-SM09M05-N		L	16	260	500	3 200	51.9	104.9	144.7
TM3-16R- R05C07-SM09M05-N		R							
TM3-12L- R05C07-SM09M05-N		L	12	260	500	3 600	48.8	98.6	138.4
TM3-12R- R05C07-SM09M05-N		R							
TM3-8L- R05C07-SM09M05-N		L	8	280	500	3 600	45.6	92.3	132.1
TM3-8R- R05C07-SM09M05-N		R							
TM3-6L- R05C07-SM09M05-N		L	6	280	500	4 000	44.0	89.2	129.0
TM3-6R- R05C07-SM09M05-N		R							
TM3-4L- R05C07-SM09M05-N		L	4	280	500	4 000	42.5	86.0	125.8
TM3-4R- R05C07-SM09M05-N		R							

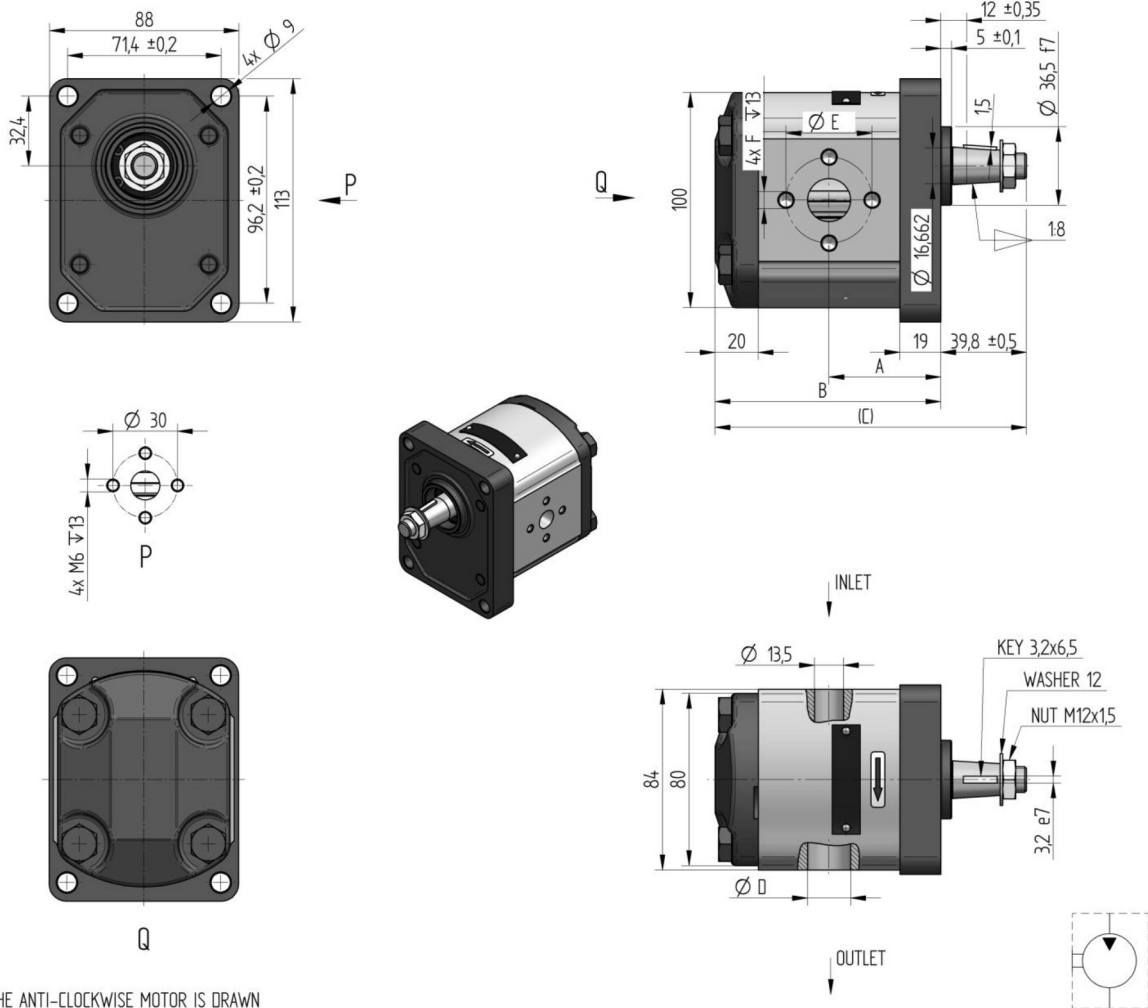

THE ANTI-CLOCKWISE MOTOR IS DRAWN

Order key	purch. code	direct. of rot.	displacement [cm ³ /1]	nom. press. [bar]	speed MIN. [min ⁻¹]	speed MAX. [min ⁻¹]	dimension					
							A [mm]	B [mm]	C [mm]	D [mm]	E [mm]	F [mm]
TM3-31L- R05C08-SK02K01-N		L	31	150	500	2 200	63.7	128.5	168.3	Ø 20	Ø 40	M8
TM3-31R- R05C08-SK02K01-N		R										
TM3-25L- R05C08-SK02K01-N		L	25	200	500	2 800	59.0	119.1	158.9	Ø 20	Ø 40	M8
TM3-25R- R05C08-SK02K01-N		R										
TM3-20L- R05C08-SK02K01-N		L	20	240	500	3 200	55.0	111.2	151.0	Ø 20	Ø 40	M8
TM3-20R- R05C08-SK02K01-N		R										
TM3-16L- R05C08-SK02K01-N		L	16	260	500	3 200	51.9	104.9	144.7	Ø 20	Ø 40	M8
TM3-16R- R05C08-SK02K01-N		R										
TM3-12L- R05C08-SK02K01-N		L	12	260	500	3 600	48.8	98.6	138.4	Ø 20	Ø 40	M8
TM3-12R- R05C08-SK02K01-N		R										
TM3-8L- R05C08-SK01K01-N		L	8	280	500	3 600	45.6	92.3	132.1	Ø 13.5	Ø 30	M6
TM3-8R- R05C08-SK01K01-N		R										
TM3-6L- R05C08-SK01K01-N		L	6	280	500	4 000	44.0	89.2	129.0	Ø 13.5	Ø 30	M6
TM3-6R- R05C08-SK01K01-N		R										
TM3-4L- R05C08-SK01K01-N		L	4	280	500	4 000	42.5	86.0	125.8	Ø 13.5	Ø 30	M6
TM3-4R- R05C08-SK01K01-N		R										

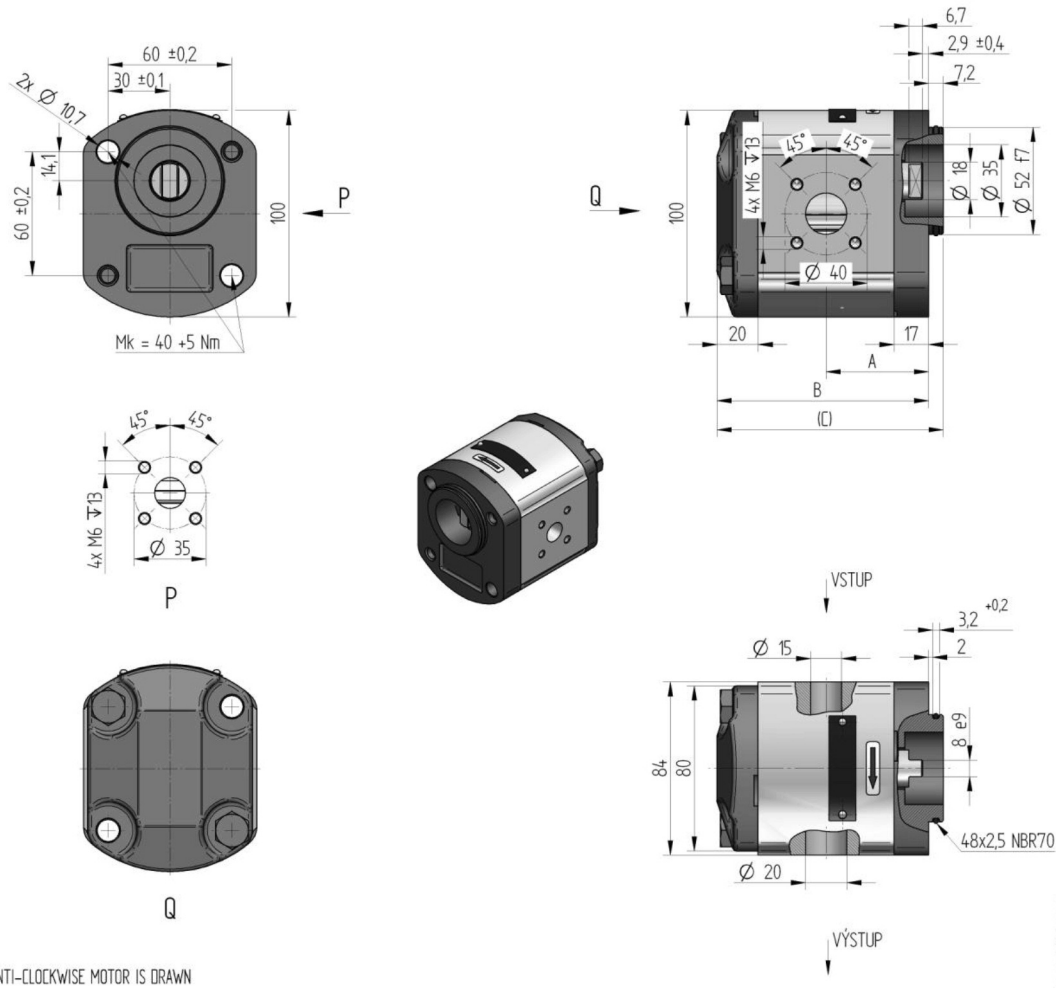

THE ANTI-CLOCKWISE MOTOR IS DRAWN

Order key	purch. code	direct. of rot.	displacement [cm ³ /1]	nom. press. [bar]	speed MIN. [min ⁻¹]	speed MAX. [min ⁻¹]	A [mm]	dimension B [mm]	C [mm]
TM3-31L-A09K07-SH06H05-N.004		L	31	150	500	2 200	61.7	126.5	133.7
TM3-31R-A09K07-SH06H05-N.004		R							
TM3-25L-A09K07-SH06H05-N.004		L	25	200	500	2 800	57.0	117.1	124.3
TM3-25R-A09K07-SH06H05-N.004		R							
TM3-20L-A09K07-SH06H05-N.004		L	20	240	500	3 200	53.0	109.2	116.4
TM3-20R-A09K07-SH06H05-N.004		R							
TM3-16L-A09K07-SH06H05-N.004		L	16	260	500	3 200	49.9	102.9	110.1
TM3-16R-A09K07-SH06H05-N.004		R							
TM3-12L-A09K07-SH06H05-N.004		L	12	260	500	3 600	46.8	96.6	103.8
TM3-12R-A09K07-SH06H05-N.004		R							
TM3-8L-A09K07-SH06H05-N.004		L	8	280	500	3 600	43.6	90.3	97.5
TM3-8R-A09K07-SH06H05-N.004		R							
TM3-6L-A09K07-SH06H05-N.004		L	6	280	500	4 000	42.0	87.2	94.4
TM3-6R-A09K07-SH06H05-N.004		R							
TM3-4L-A09K07-SH06H05-N.004		L	4	280	500	4 000	40.5	84.0	91.2
TM3-4R-A09K07-SH06H05-N.004		R							

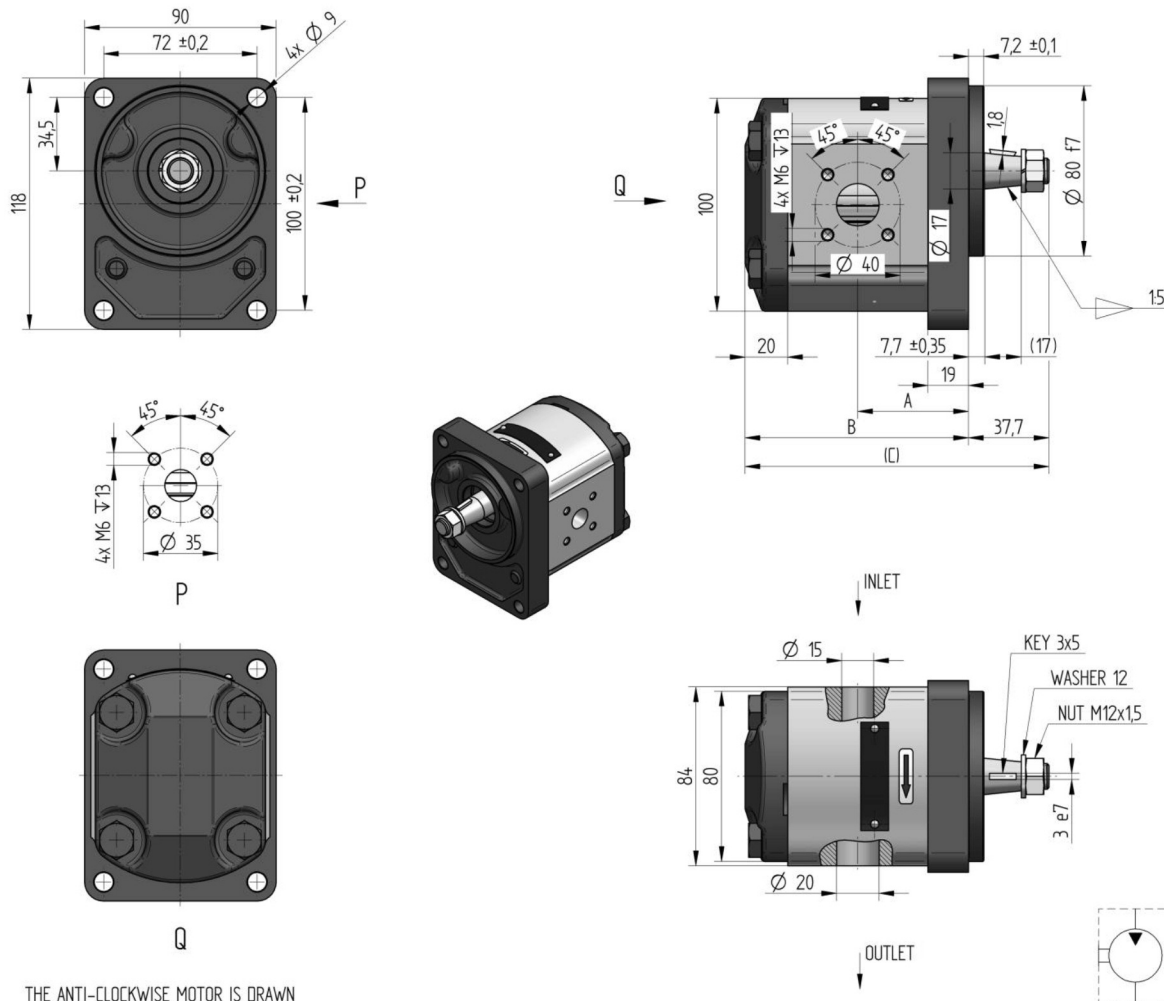

THE ANTI-CLOCKWISE MOTOR IS DRAWN

Order key	purchase code	direct. of rot.	displacement [cm ³ /1]	nom. press. [bar]	speed MIN. [min ⁻¹]	speed MAX. [min ⁻¹]	A [mm]	dimension B [mm]	C [mm]
TM3-31L-R06C10-SH06H05-N		L	31	150	500	2 200	63.7	128.5	168.3
TM3-31R-R06C10-SH06H05-N		R							
TM3-25L-R06C10-SH06H05-N		L	25	200	500	2 800	59.0	119.1	158.9
TM3-25R-R06C10-SH06H05-N		R							
TM3-20L-R06C10-SH06H05-N		L	20	240	500	3 200	55.0	111.2	151.0
TM3-20R-R06C10-SH06H05-N		R							
TM3-16L-R06C10-SH06H05-N		L	16	260	500	3 200	51.9	104.9	144.7
TM3-16R-R06C10-SH06H05-N		R							
TM3-12L-R06C10-SH06H05-N		L	12	260	500	3 600	48.8	98.6	138.4
TM3-12R-R06C10-SH06H05-N		R							
TM3-8L-R06C10-SH06H05-N		L	8	280	500	3 600	45.6	92.3	132.1
TM3-8R-R06C10-SH06H05-N		R							
TM3-6L-R06C10-SH06H05-N		L	6	280	500	4 000	44.0	89.2	129.0
TM3-6R-R06C10-SH06H05-N		R							
TM3-4L-R06C10-SH06H05-N		L	4	280	500	4 000	42.5	86.0	125.8
TM3-4R-R06C10-SH06H05-N		R							

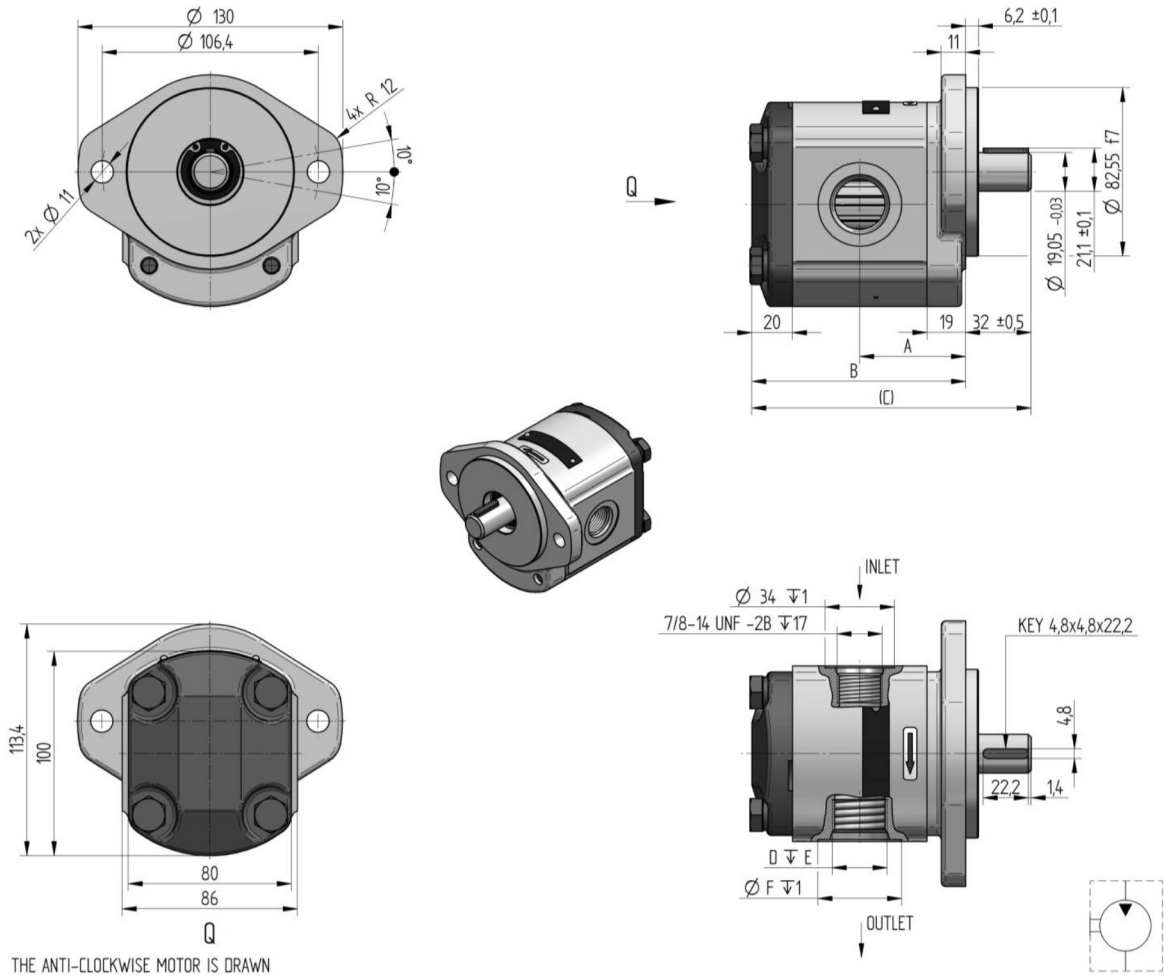

Order key	purch. code	direct. of rot.	displacement [cm ³ /1]	nom. press. [bar]	speed MIN. [min ⁻¹]	speed MAX. [min ⁻¹]	dimension					
							A [mm]	B [mm]	C [mm]	D [mm]	E [mm]	F [mm]
TM3-31L- S02V12-SU05U04-N		L	31	150	500	2 200	63.7	128.5	160.5	1-1/16-12 UN-2B	19	41
TM3-31R- S02V12-SU05U04-N		R										
TM3-25L- S02V12-SU05U04-N		L	25	200	500	2 800	59.0	119.1	151.1	1-1/16-12 UN-2B	19	41
TM3-25R- S02V12-SU05U04-N		R										
TM3-20L- S02V12-SU05U04-N		L	20	240	500	3 200	55.0	111.2	143.2	1-1/16-12 UN-2B	19	41
TM3-20R- S02V12-SU05U04-N		R										
TM3-16L- S02V12-SU05U04-N		L	16	260	500	3 200	51.9	104.9	136.9	1-1/16-12 UN-2B	19	41
TM3-16R- S02V12-SU05U04-N		R										
TM3-12L- S02V12-SU05U04-N		L	12	260	500	3 600	48.8	98.6	130.6	1-1/16-12 UN-2B	19	41
TM3-12R- S02V12-SU05U04-N		R										
TM3-8L- S02V12-SU04U04-N		L	8	280	500	3 600	45.6	92.3	124.3	7/8-14 UNF-2B	17	34
TM3-8R- S02V12-SU04U04-N		R										
TM3-6L- S02V12-SU04U04-N		L	6	280	500	4 000	44.0	89.2	121.2	7/8-14 UNF-2B	17	34
TM3-6R- S02V12-SU04U04-N		R										
TM3-4L- S02V12-SU04U04-N		L	4	280	500	4 000	42.5	86.0	118.0	7/8-14 UNF-2B	17	34
TM3-4R- S02V12-SU04U04-N		R										

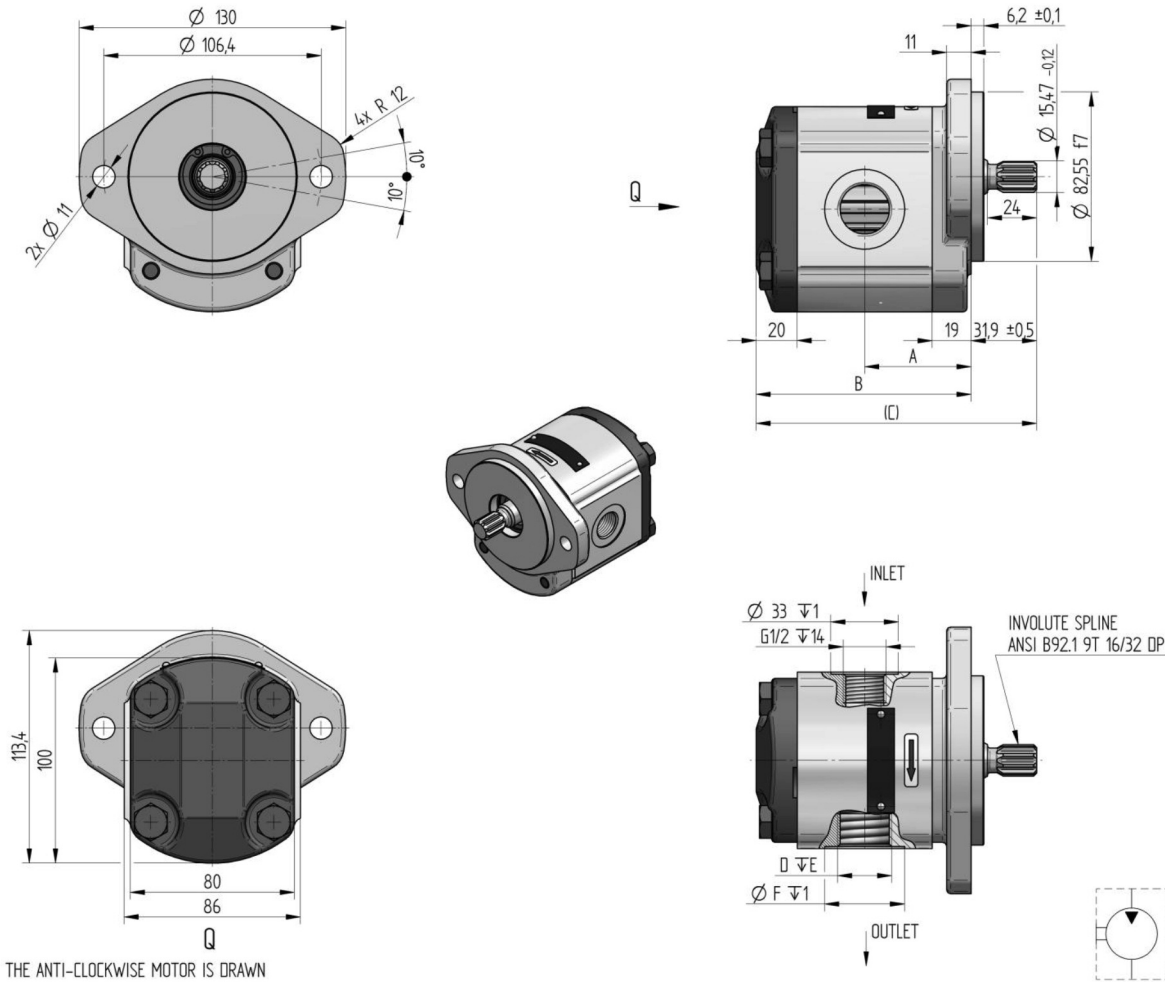

THE ANTI-CLOCKWISE MOTOR IS DRAWN

Order key	purch. code	direct. of rot.	displacement [cm ³ /1]	nom. press. [bar]	speed MIN. [min ⁻¹]	speed MAX. [min ⁻¹]	dimension					
							A [mm]	B [mm]	C [mm]	D [mm]	E [mm]	F [mm]
TM3-31L-S02D04-SG04G03-N		L	31	150	500	2 200	63.7	128.5	160.6	G 3/4	16	39
TM3-31R-S02D04-SG04G03-N		R										
TM3-25L-S02D04-SG04G03-N		L	25	200	500	2 800	59.0	119.1	151.2	G 3/4	16	39
TM3-25R-S02D04-SG04G03-N		R										
TM3-20L-S02D04-SG04G03-N		L	20	240	500	3 200	55.0	111.2	143.3	G 3/4	16	39
TM3-20R-S02D04-SG04G03-N		R										
TM3-16L-S02D04-SG04G03-N		L	16	260	500	3 200	51.9	104.9	137.0	G 3/4	16	39
TM3-16R-S02D04-SG04G03-N		R										
TM3-12L-S02D04-SG04G03-N		L	12	260	500	3 600	48.8	98.6	130.7	G 3/4	16	39
TM3-12R-S02D04-SG04G03-N		R										
TM3-8L-S02D04-SG03G03-N		L	8	280	500	3 600	45.6	92.3	124.4	G 1/2	14	33
TM3-8R-S02D04-SG03G03-N		R										
TM3-6L-S02D04-SG03G03-N		L	6	280	500	4 000	44.0	89.2	121.3	G 1/2	14	33
TM3-6R-S02D04-SG03G03-N		R										
TM3-4L-S02D04-SG03G03-N		L	4	280	500	4 000	42.5	86.0	118.1	G 1/2	14	33
TM3-4R-S02D04-SG03G03-N		R										

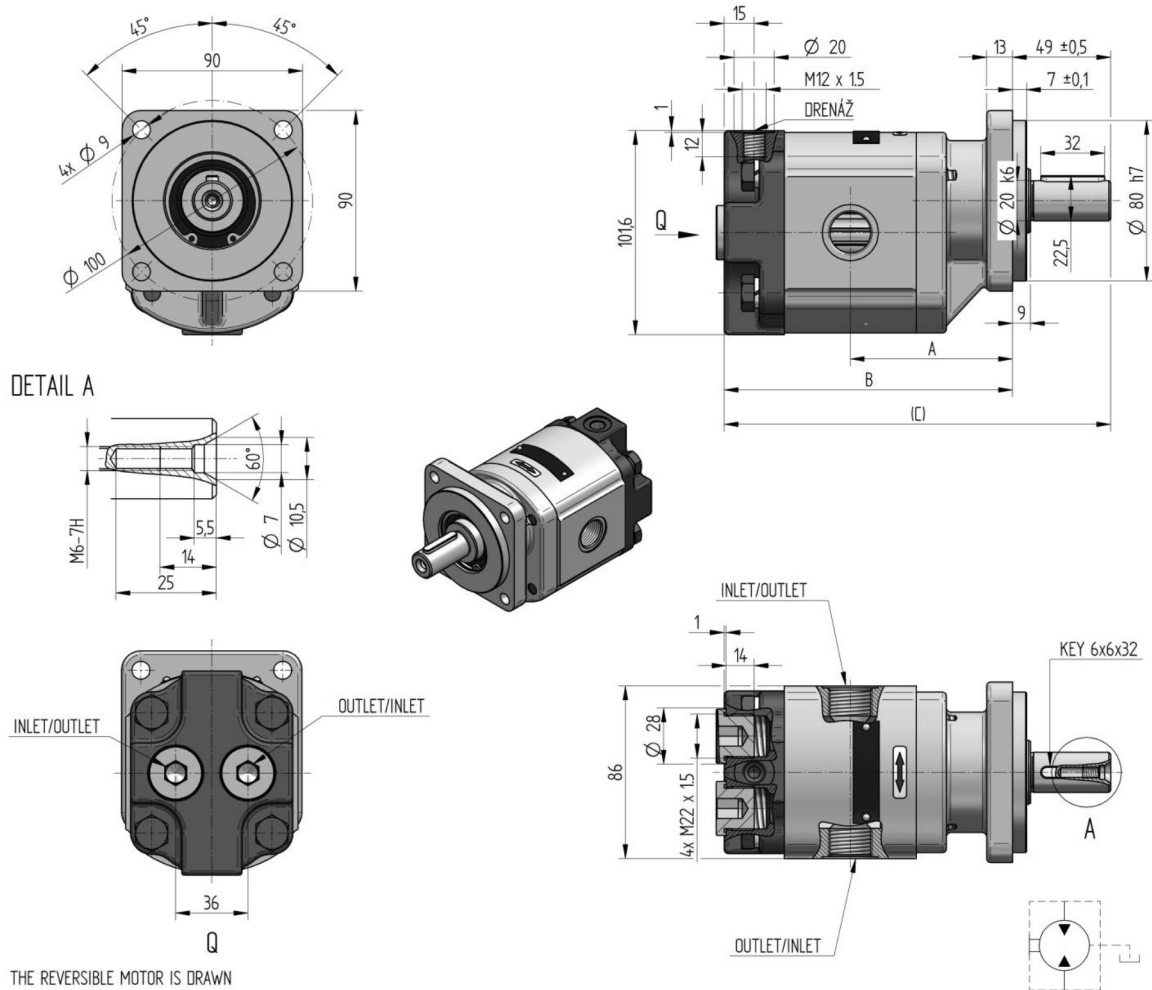

THE REVERSIBLE MOTOR IS DRAWN

Order key	purch. code	direct. of rot.	displacement [cm ³ /1]	nom. press. [bar]	speed MIN. [min ⁻¹]	speed MAX. [min ⁻¹]	dimension		
							A [mm]	B [mm]	C [mm]
TM3-13B-F02D10-CM07M07-N.027	184 9217	B	13	260	300	3500	78.6	139.1	188.1

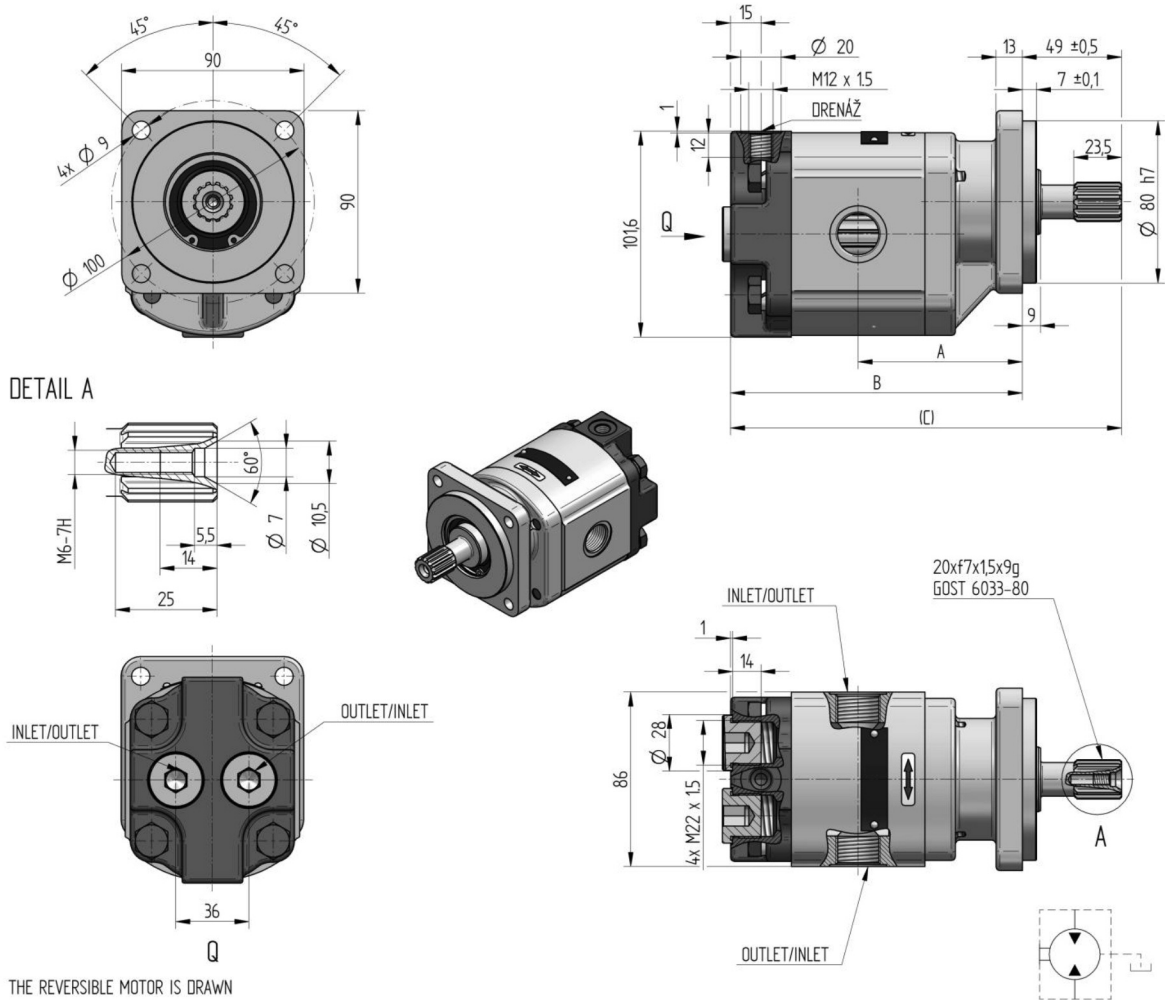

Order key	purch. code	direct. of rot.	displacement [cm ³ /1]	nom. press. [bar]	speed MIN. [min ⁻¹]	speed MAX. [min ⁻¹]	dimension		
							A [mm]	B [mm]	C [mm]
TM3-13B-F02V13-CM07M07-N.027	184 9215	B	13	260	300	3500	78.6	139.1	188.1

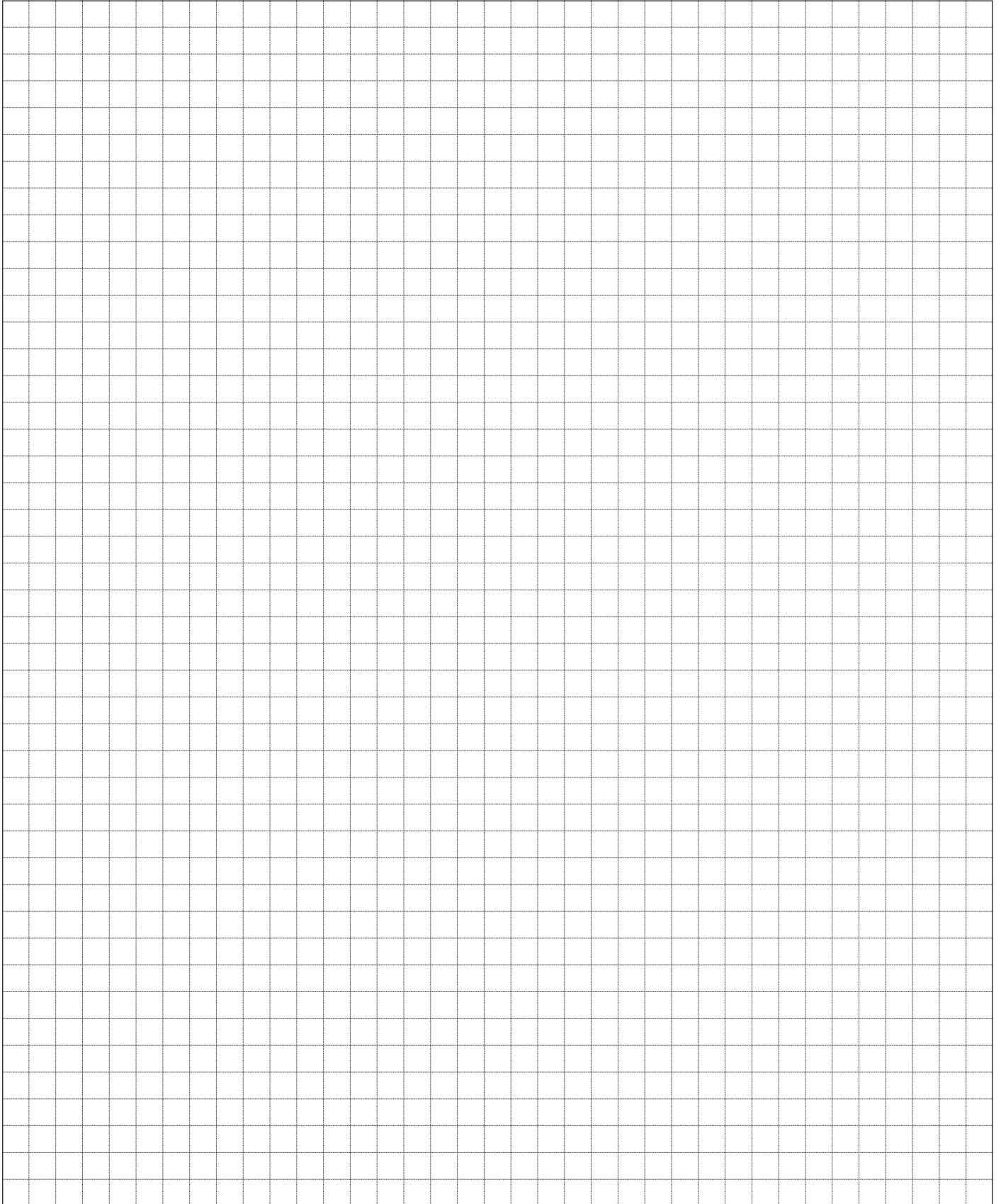

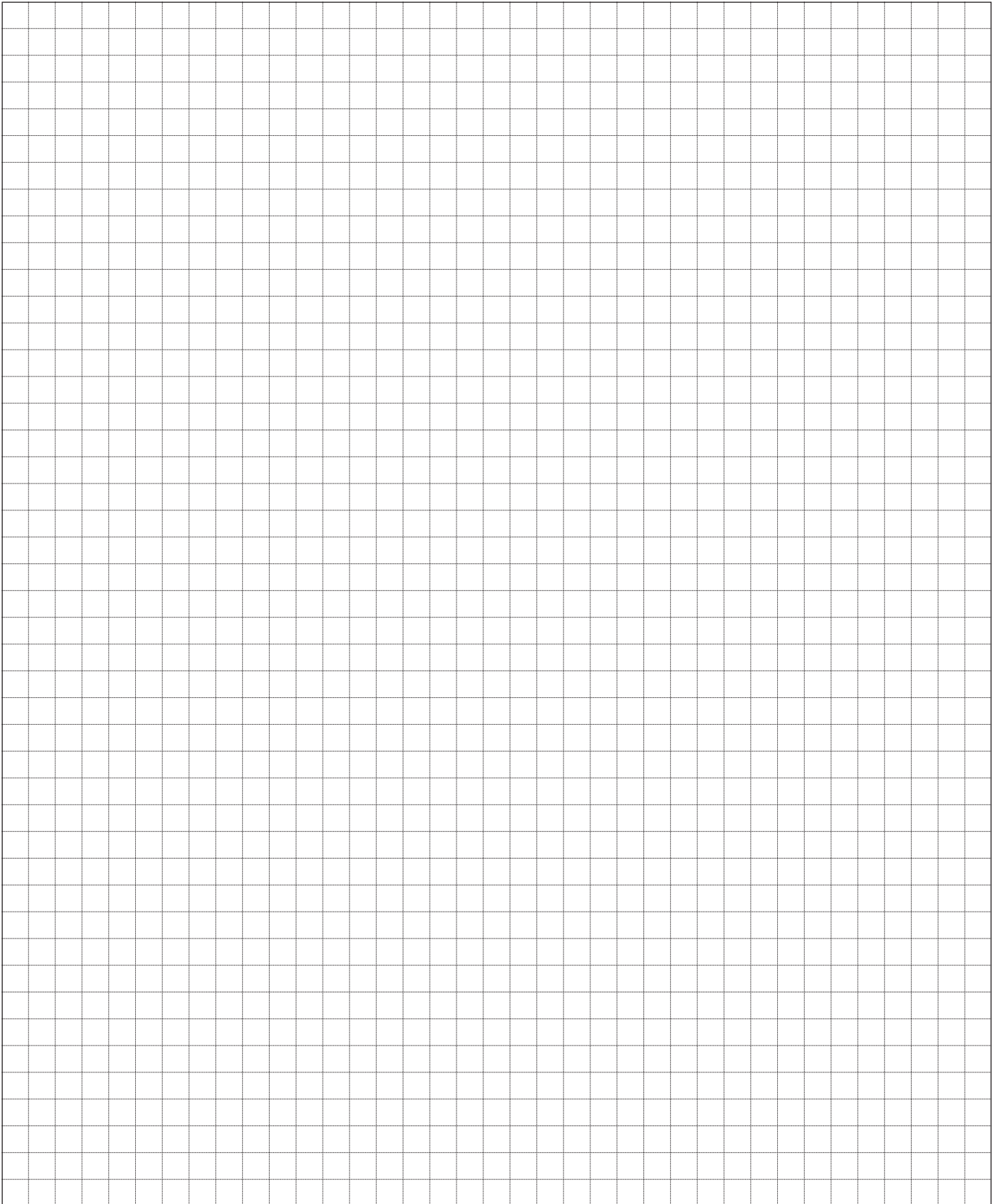

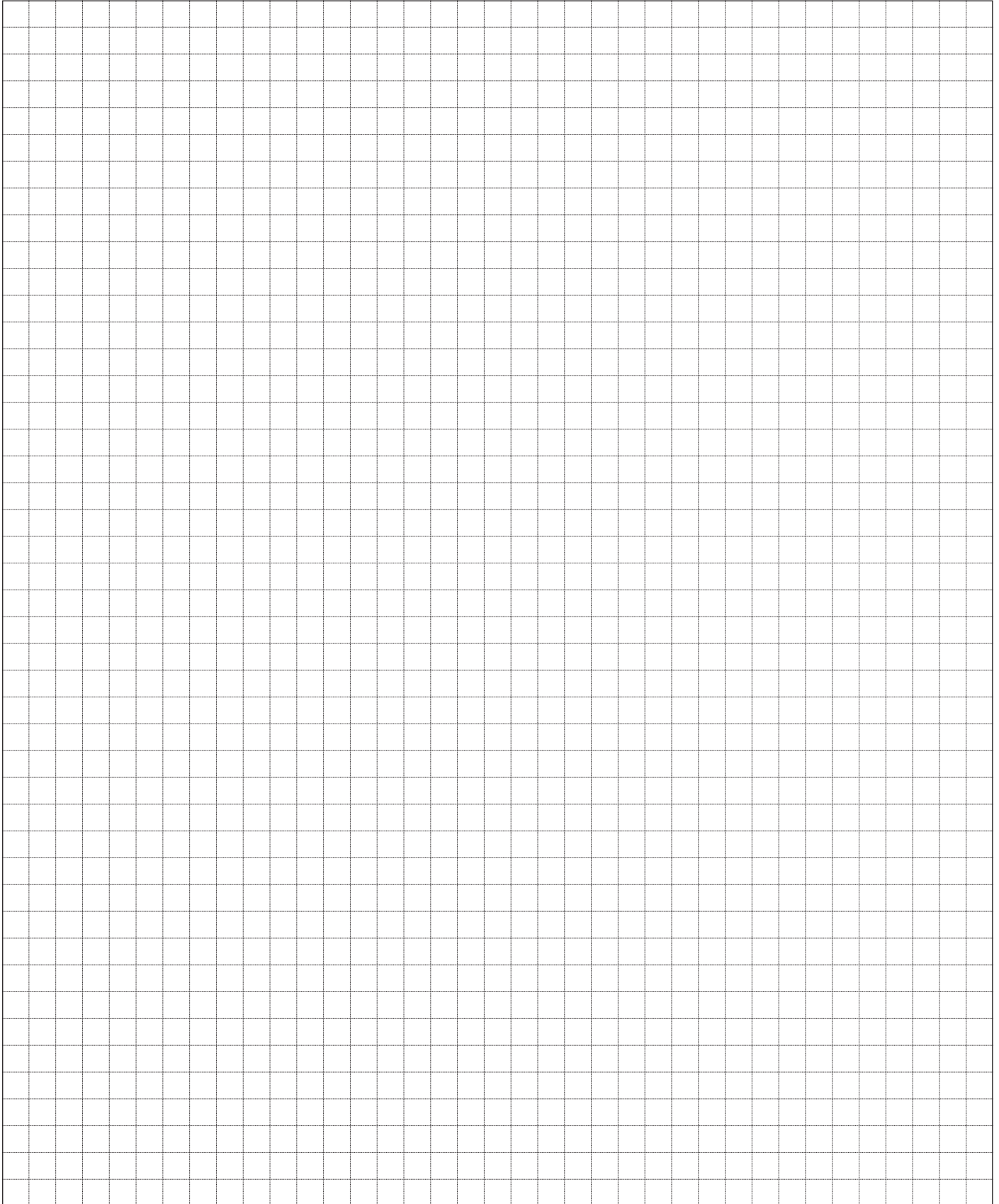

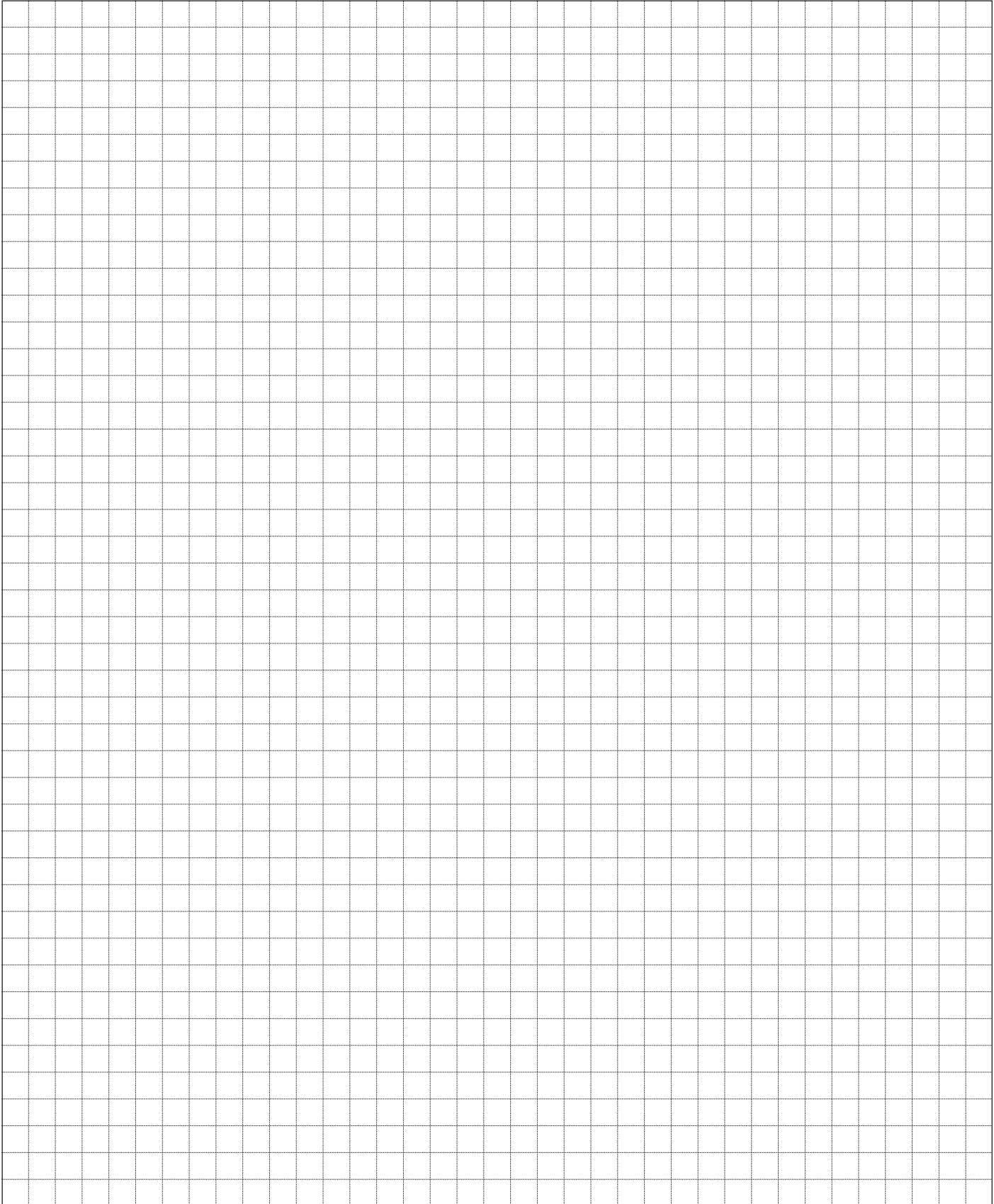



jihostroj
AERO TECHNOLOGY & HYDRAULICS

JIHOSTROJ a.s.
Budějovická 148
CZ 382 32 Velešín
Czech Republic
tel.: +420 380 340 511
fax: +420 380 340 612
e-mail: mailbox@jihostroj.cz
http: //www.jihostroj.com

GPS 48°49'51.748" N 14°27'40.770" E

