

Displacement from 10 to 100 ccm
Pressure up to 300 bar
Speed from 300 to 3200 RPM

GEAR PUMPS
QHD1

TABLE OF CONTENTS

DESCRIPTION.....	2
BASIC PARTS OF PUMP.....	2
PARAMETER TABLE.....	3
FORMULAS USED FOR CALCULATION.....	4
PUMP EFFICIENCIES.....	4
WORKING LIQUID.....	5
PRESSURE LOAD.....	5
OTHER REQUIREMENTS.....	6
DIRECTION OF ROTATION.....	6
REVERSIBLE DESIGN.....	6
QHD1 FLOW RATE AND POWER CURVES.....	7
ORDER KEY.....	11
COMBINATION OF FLANGES AND SHAFTS.....	12
FLANGE DESIGN.....	13
DRIVE SHAFTS.....	13
COMBINATION OF LIQUID INLETS AND OUTLETS.....	15
CATALOGUE SHEETS OF QHD1 SERIES.....	17
NOTES.....	21

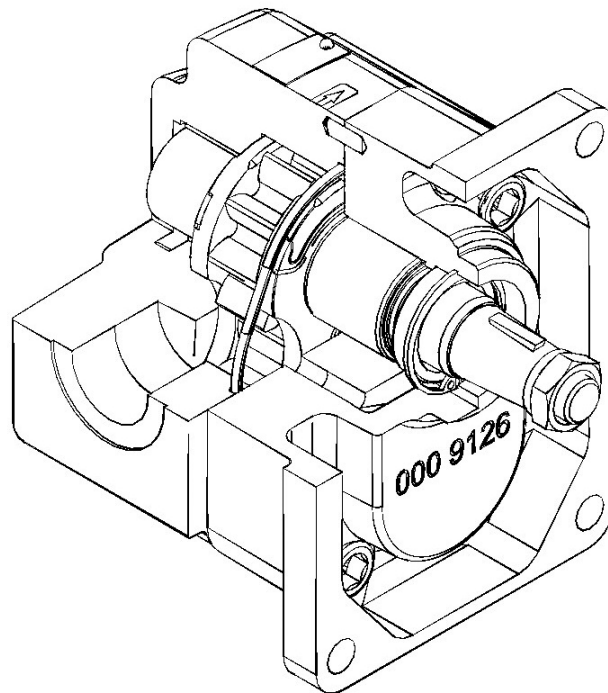

DESCRIPTION

- QHD1 series are particularly designed to be used in mobile hydraulic systems of agricultural, heavy construction and road building machines as well as in advanced hydraulic systems of material handling devices. The QHD1 series covers the range of displacements from 10 to 100 cm³/rev.
- The pumps are characterized by simple construction with hydraulic pressure balance, compact dimensions and a wide range of connection types. QHD1 pumps have a two-piece all-cast-iron construction. The basis consists of a supporting body with a blind chamber for gear wheels and a fastening flange. The body as well as the flange are made of a high-quality grey cast iron. In the body and the flange, sliding sleeves for gear wheels are molded. Gear wheels with 12 teeth made of ultra high-strength steel, which are optimised to achieve a low noise level. The axial pump balancing is performed using sliding aluminium alloy pressure plates in which a shape sealing of balancing surface is located in grooves. For heavy duty with a weight-bearing drive shaft, the pumps can be equipped with front-end roller bearings. QHD1 construction enables the pumps to be used already at low revolutions at high pressure.
- QHD1 pumps are produced in various designs of divers clamping flanges as well as liquid inlets and outlets. These pumps comply with the standards ISO, SAE, UNI and other world-recognised standards and can be delivered in simple or multiple designs. They can also be delivered in a reversible design, with external or internal drainage.

BASIC PARTS OF PUMP

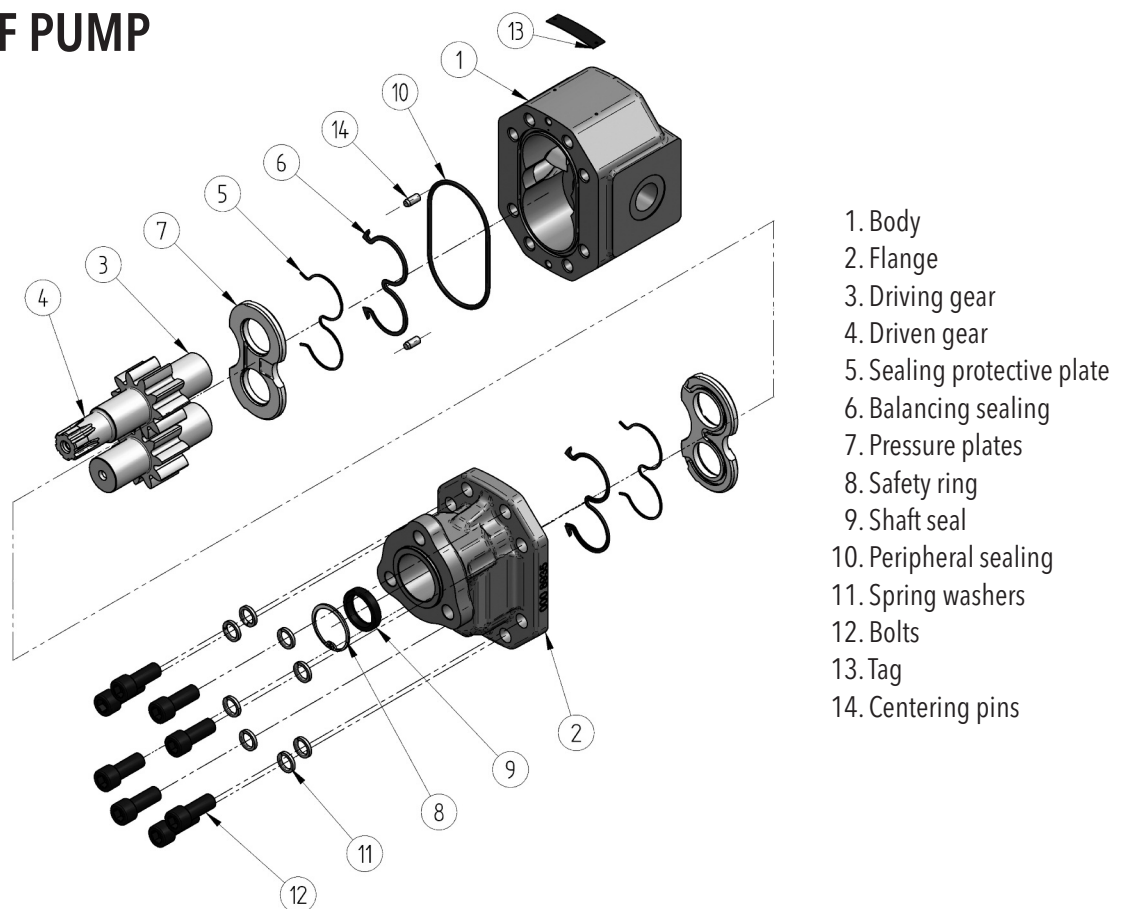

1. Body
2. Flange
3. Driving gear
4. Driven gear
5. Sealing protective plate
6. Balancing sealing
7. Pressure plates
8. Safety ring
9. Shaft seal
10. Peripheral sealing
11. Spring washers
12. Bolts
13. Tag
14. Centering pins

PARAMETER TABLE

Nominal Size Parameters		Sym.	Unit	QHD1 10	QHD1 17	QHD1 27	QHD1 34	QHD1 43
Actual displacement		V_g	[cm ³]	10.11	17.24	27.35	34.05	43.47
Rotation speed	nominal	n_n	[min ⁻¹]	1500	1500	1500	1500	1500
	minimum	n_{min}	[min ⁻¹]	350	350	350	350	350
	maximum	n_{max}	[min ⁻¹]	3200	3200	3200	3000	2800
Pressure at inlet*	minimum	p_{1min}	[bar]	-0.3	-0.3	-0.3	-0.3	-0.3
	maximum	p_{1max}	[bar]	0.5	0.5	0.5	0.5	0.5
Pressure at outlet**	max. continuous	p_{2n}	[bar]	290	290	290	300	280
	maximum	p_{2max}	[bar]	310	310	310	320	300
	peak	p_3	[bar]	320	320	320	330	310
Nominal flow rate (min.) at n_n and p_{2n}		Q_n	[dm ³ .min ⁻¹]	13.7	23.2	37.0	47.5	60.6
Maximum flow rate at n_{max} a p_{2max}		Q_{max}	[dm ³ .min ⁻¹]	31.80	54.30	86.20	100.60	119.93
Nominal input power (max.) at n_n and p_{2n}		P_n	[kW]	8.7	14.8	23.4	30.0	35.8
Maximum input power at n_{max} a p_{2max}		P_{max}	[kW]	19.7	33.6	53.2	64.1	71.6
Weight		m	[kg]	10.4	10.9	11.7	12.1	13.0

Nominal Size Parameters		Sym.	Unit	QHD1 51	QHD1 61	QHD1 71	QHD1 82	QHD1 100
Actual displacement		V_g	[cm ³]	51.44	61.59	71.01	81.87	99.98
Rotation speed	nominal	n_n	[min ⁻¹]	1500	1500	1500	1500	1500
	minimum	n_{min}	[min ⁻¹]	350	350	300	300	300
	maximum	n_{max}	[min ⁻¹]	2600	2400	2200	2000	1800
Pressure at inlet*	minimum	p_{1min}	[bar]	-0.3	-0.3	-0.3	-0.3	-0.3
	maximum	p_{1max}	[bar]	0.5	0.5	0.5	0.5	0.5
Pressure at outlet**	max. continuous	p_{2n}	[bar]	260	260	230	200	180
	maximum	p_{2max}	[bar]	280	280	250	220	200
	peak	p_3	[bar]	290	290	260	230	210
Nominal flow rate (min.) at n_n and p_{2n}		Q_n	[dm ³ .min ⁻¹]	71.8	85.9	99.0	114.2	139.5
Maximum flow rate at n_{max} a p_{2max}		Q_{max}	[dm ³ .min ⁻¹]	131.7	145.6	153.9	161.3	177.3
Nominal input power (max.) at n_n and p_{2n}		P_n	[kW]	40.8	45.3	48.0	48.2	52.9
Maximum input power at n_{max} a p_{2max}		P_{max}	[kW]	76.0	78.2	76.6	70.6	70.6
Weight		m	[kg]	13.5	14.0	14.8	15.7	17.8

* Inlet pressure in the reversible design can be up to $p_1 = p_{2n}$ -70 bar max. External drainage must be used in case of the reversible design.

** Outlet pressure in the reversible design is **10% lower** than shown in the table (depending on operating conditions - it is necessary to consult with the manufacturer).

FORMULAS USED FOR CALCULATION

Flow rate
 Q

$$Q = \frac{V_g \cdot n}{1000} \cdot \eta_v \quad [\text{dm}^3 \cdot \text{min}^{-1}]$$

V_g [cm³] pump displacement
 n [min⁻¹] rotation speed
 η_v [-] volumetric efficiency

Displacement
 V_g

$$V_g = \frac{Q \cdot 1000}{n \cdot \eta_v} \quad [\text{cm}^3]$$

Torque
 M_k

$$M_k = \frac{V_g \cdot p}{20 \cdot \pi \cdot \eta_m} \quad [\text{Nm}]$$

p [bar] required pressure at outlet
 η_m [-] mechanical efficiency

Input power
 P

$$P = \frac{V_g \cdot n \cdot p}{600 \cdot 1000 \cdot \eta_t} \quad [\text{kW}]$$

η_t [-] total efficiency

PUMP EFFICIENCIES

Volumetric efficiency
It determines the amount of flow losses. Its value is $\eta_v = 0,92 \div 0,98$ (depending on rotation speed, viscosity of working liquid and outlet pressure). It can be expressed as follows:

η_v

$$\eta_v = \frac{Q_{act.}}{Q_{theor}} \quad [-]$$

$Q_{act.}$ [dm³ · min⁻¹] actual flow rate
 Q_{theor} [dm³ · min⁻¹] theoretical flow rate

Mechanical efficiency
It determines mechanical losses. Its value is about $\eta_m = 0,85$.
It can be expressed as follows:

η_m

$$\eta_m = \frac{M_{theor}}{M_{act.}} \quad [-]$$

$M_{act.}$ [Nm] actual torque
 M_{theor} [Nm] theoretical torque

Total efficiency
 η_t is defined as product of η_n and η_m and determines difference between theoretical and actual required input power:

η_t

$$\eta_t = \eta_v \cdot \eta_m = \frac{P_{theor}}{P_{act.}} \quad [-]$$

$P_{act.}$ [kW] actual input power
 P_{theor} [kW] theoretical input power

WORKING LIQUID

- Mineral oils for hydraulic drives
- Hydraulic liquids based on plant oils suitable for hydraulic drives

Liquid temperature

- $t = -20 \div +80$ [°C]
when used with FKM (Viton) seal up to 120 [°C]

Cinematic viscosity

- Recommended (during continuous operation): $\nu = 20 \div 80 \cdot 10^{-6}$ [m² · s⁻¹]
- Maximum (cold starting, at viscosity >1000, operating pressure <10 bar is permissible, speed <1500·min⁻¹): $\nu = 1200 \cdot 10^{-6}$ [m² · s⁻¹]
- Minimum (operating mode at $10 \cdot 10^{-6}$ up $20 \cdot 10^{-6}$ should be consulted with manufacturer): $\nu = 10 \cdot 10^{-6}$ [m² · s⁻¹]

Filtration coefficient β_{α}

$\beta_{25\ 75} \geq$ (for pressure $p_2 < 200$ bar)
 $\beta_{10\ 75} \geq$ (for pressure $p_2 > 200$ bar)

Liquid contamination class according to ISO 4406

21/18/15 (for pressure $p_2 < 200$ bar)
20/17/14 (for pressure $p_2 > 200$ bar)

Liquid contamination class according to NAS 1638

10 (for pressure $p_2 < 200$ bar)
8 (for pressure $p_2 > 200$ bar)

PRESSURE LOAD

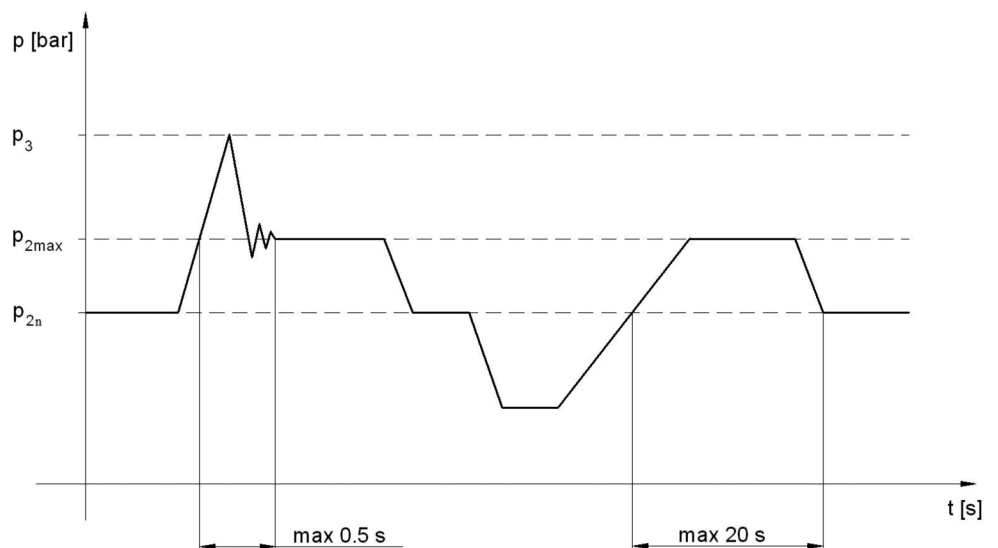

- p_{2n} max. contin. pressure** Max. working pressure, at which the pump can be operated without time limitation.
- p_{2max} max. pressure** Maximum pressure permissible for a short time, max. 20s.
- p_3 peak pressure** Short-time pressure (fractions of a second) arising in case of a sudden change of the operating mode; any excess of this pressure during operation is impermissible.

OTHER REQUIREMENTS

- A driving device must not generate an axial or a radial load of the pump shaft, unless this is exclusively permitted for the pump with a front-end bearing.
- All the matters affecting technical parameters and properties of the pump are given in respective operating manuals, technical specifications and test specifications of the manufacturer.

DIRECTION OF ROTATION

- Determine direction of rotation by looking at the drive shaft. The pump can only be used in the specified direction of rotation.

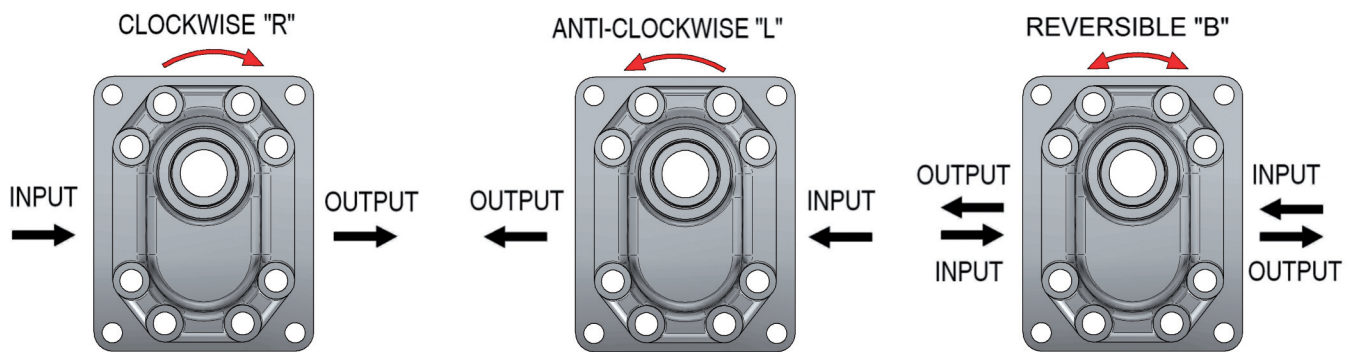

REVERSIBLE DESIGN

- The pumps with the possibility of bidirectional rotation have a different internal arrangement requiring drainage. Two types are used - internal and external. The internal drainage is always interconnected with the outlet by means of valves. The external drainage is solved by an orifice located in the body opposite the driven gear.

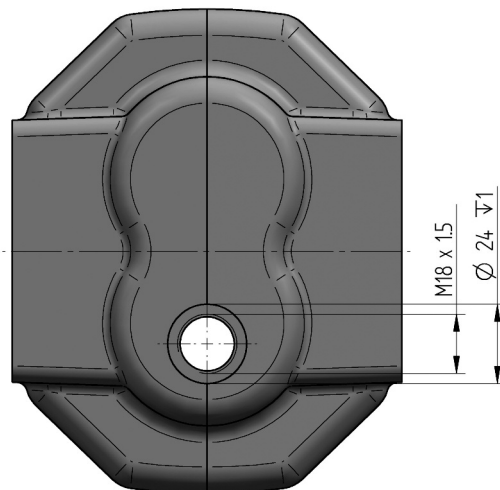

QHD1 FLOW RATE AND POWER CURVES

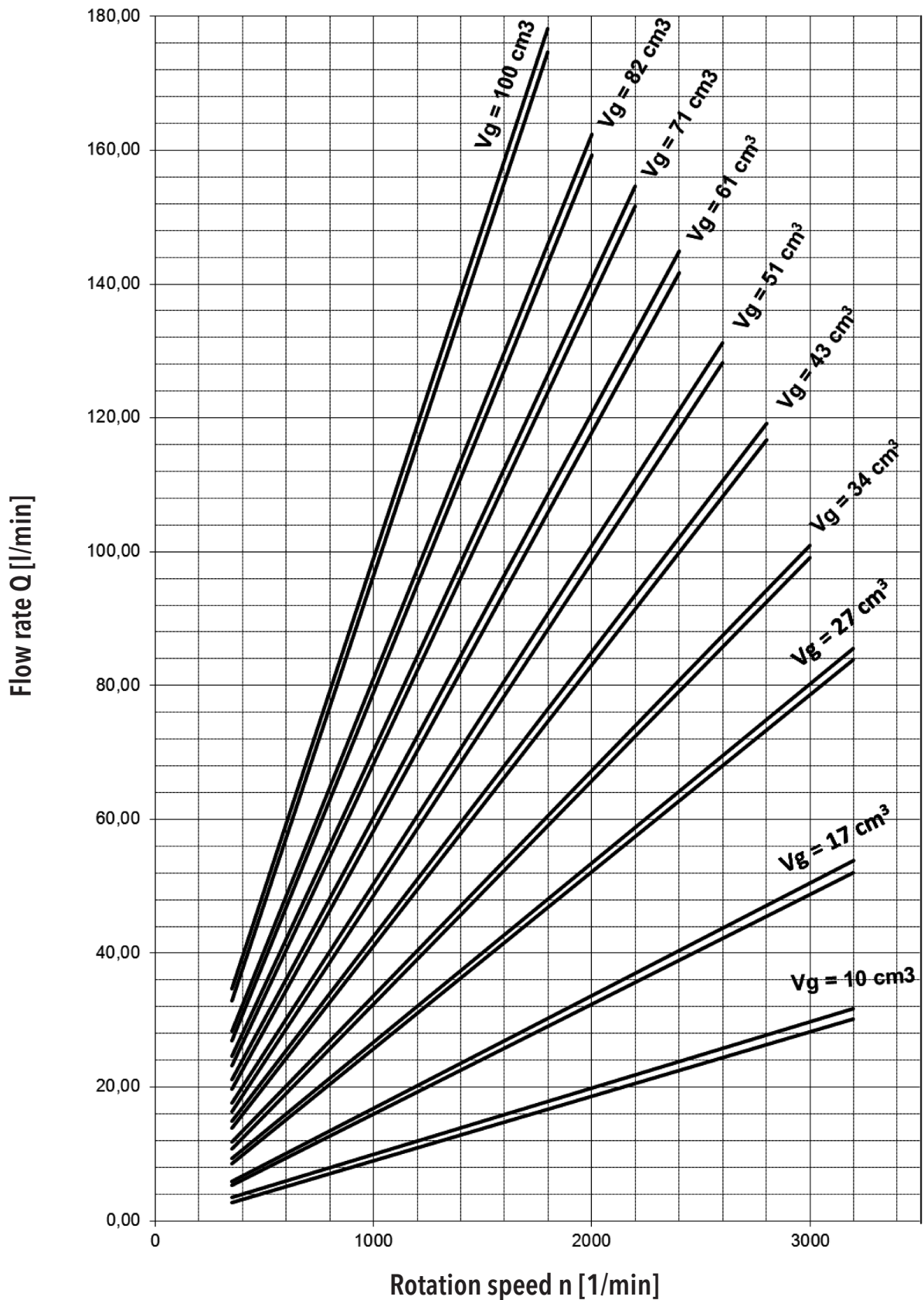

Above curves apply to ISO Vg 46 oil at temperature $t = 45^{\circ}\text{C}$.

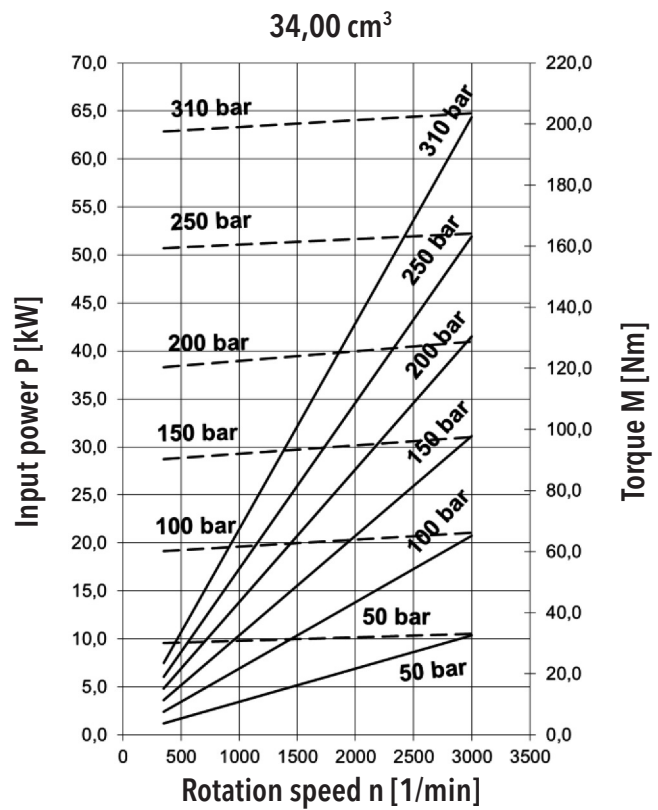
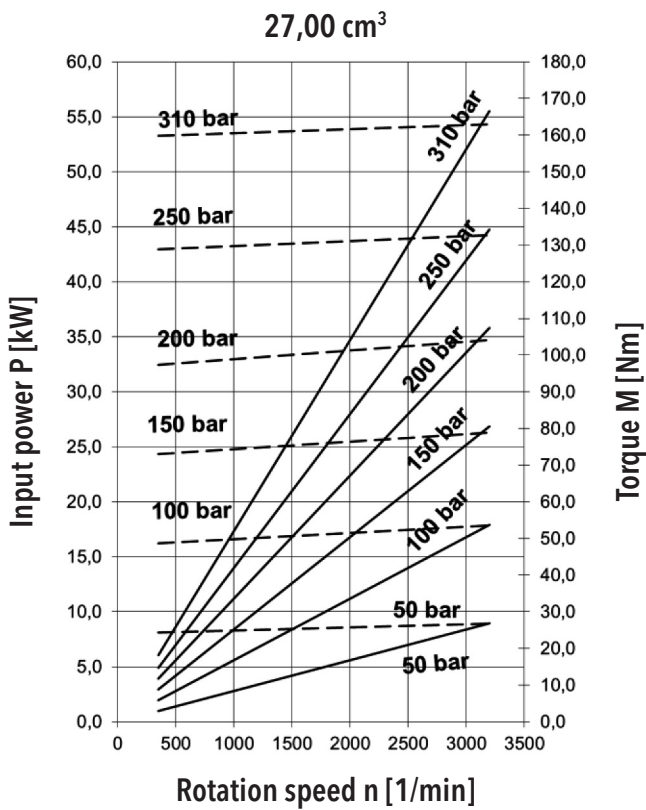
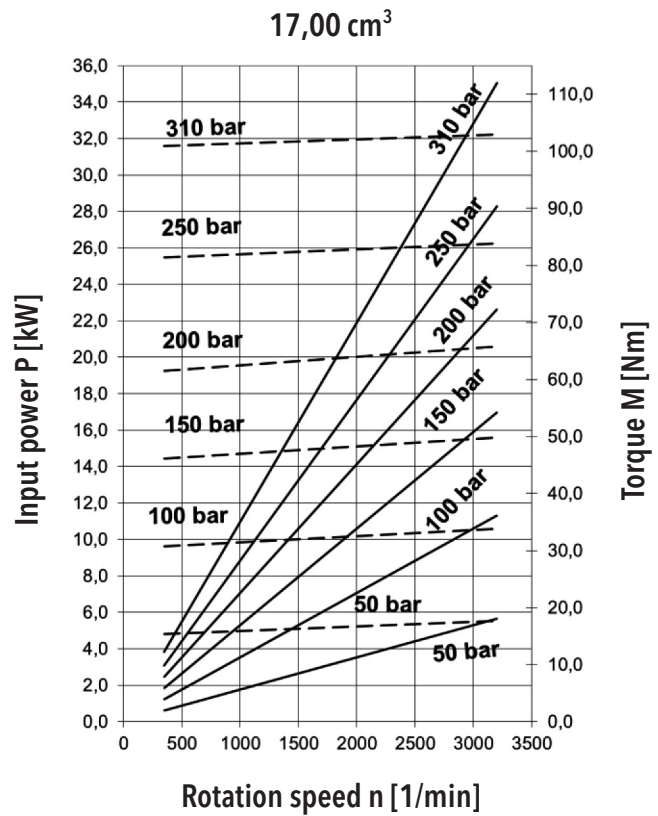
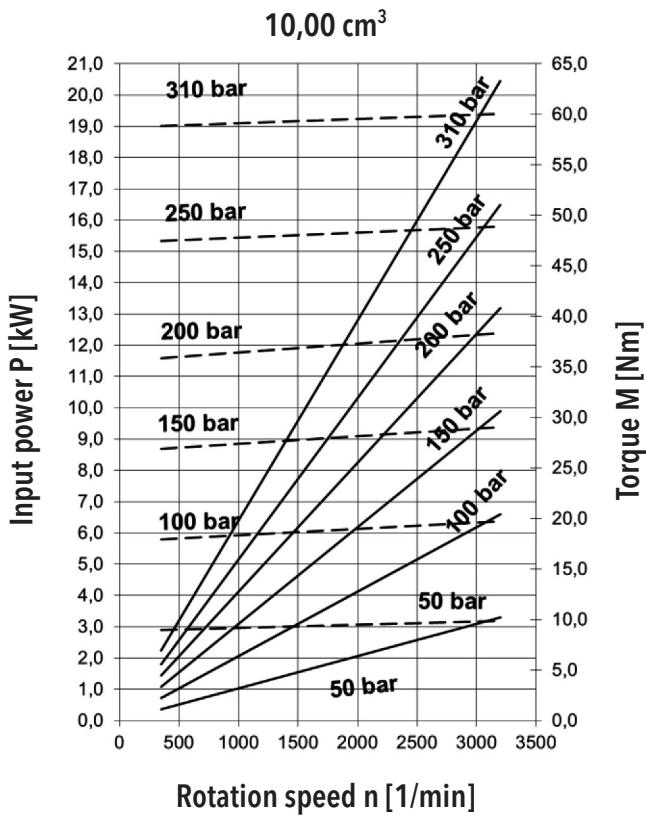

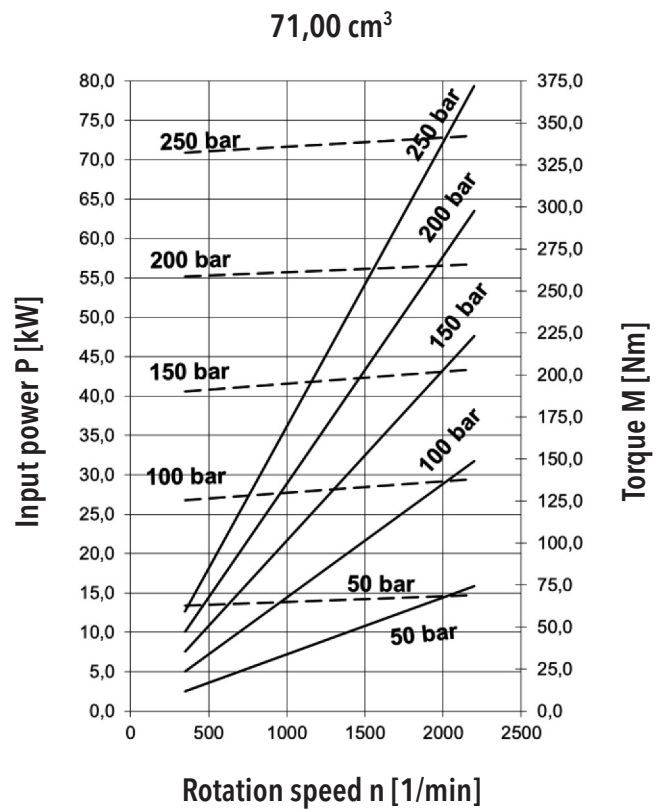
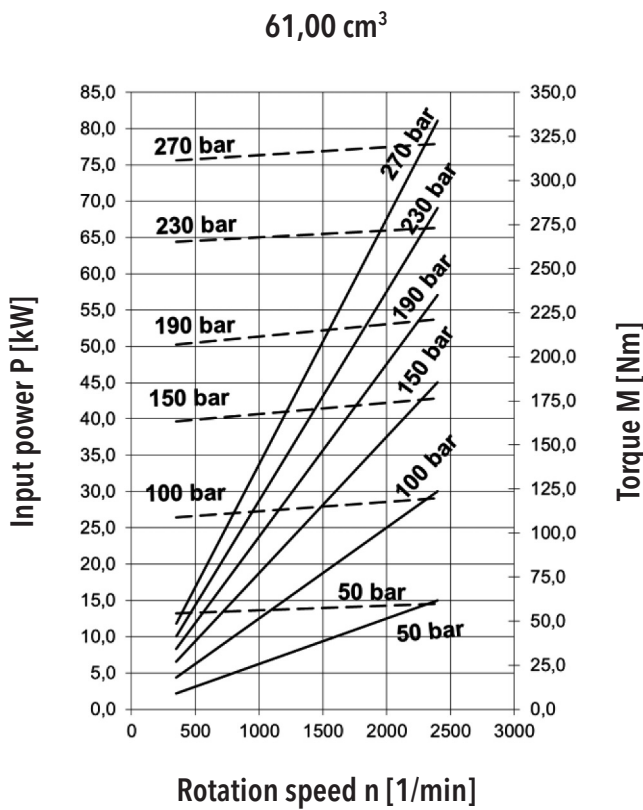
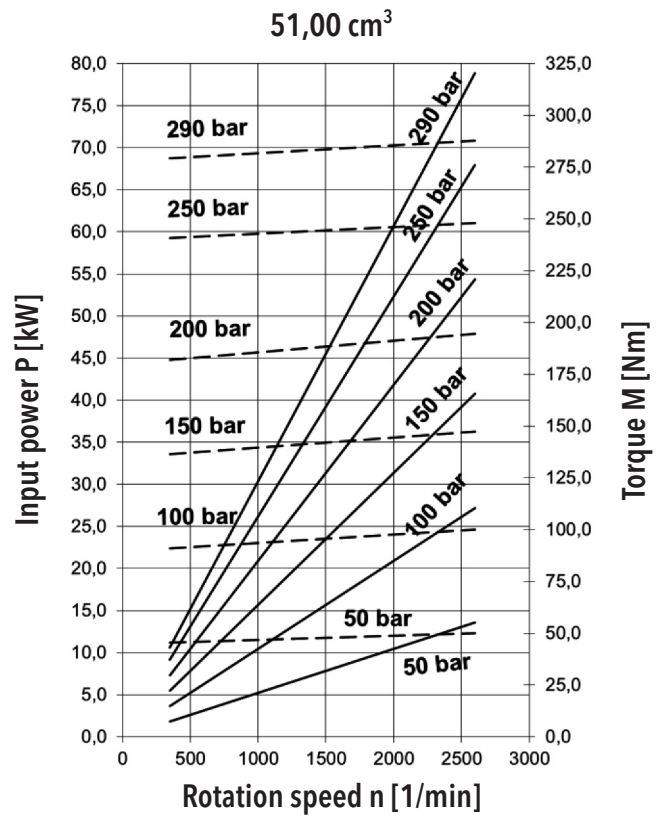
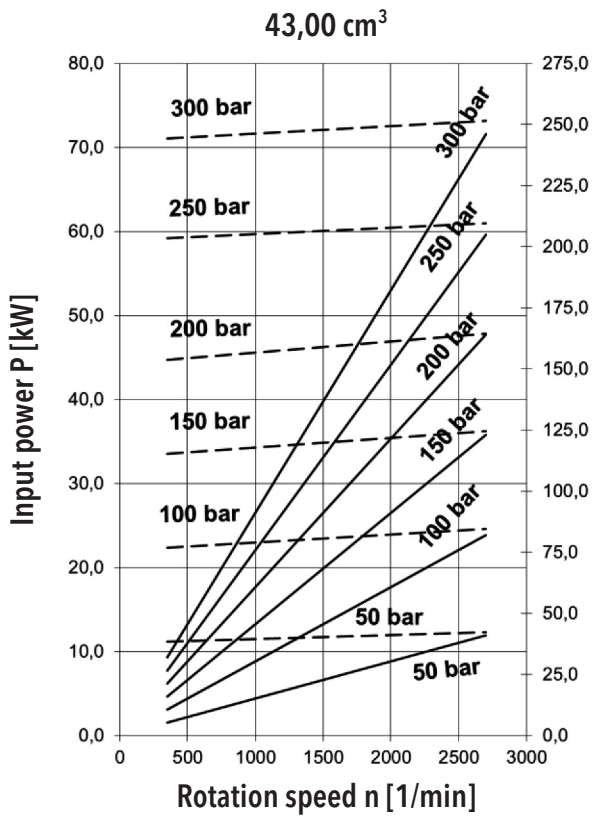

82,00 cm³

100,00 cm³

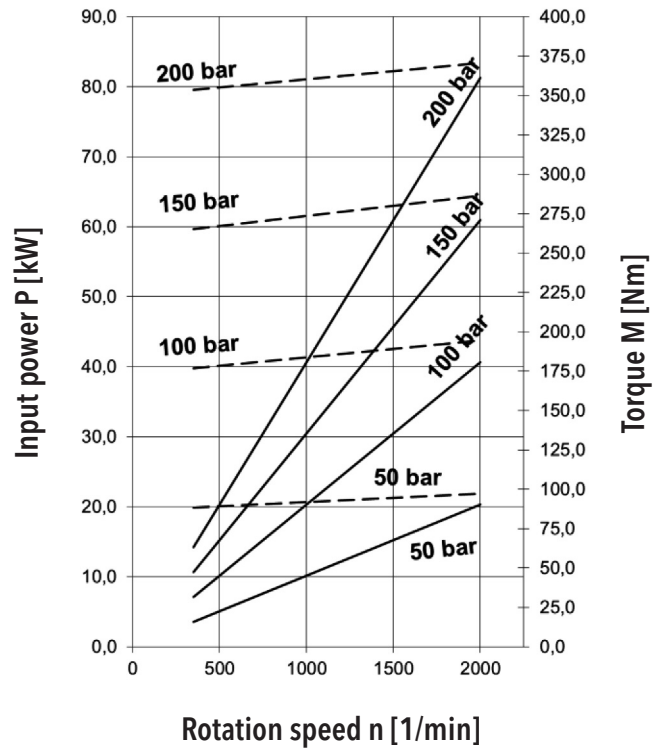
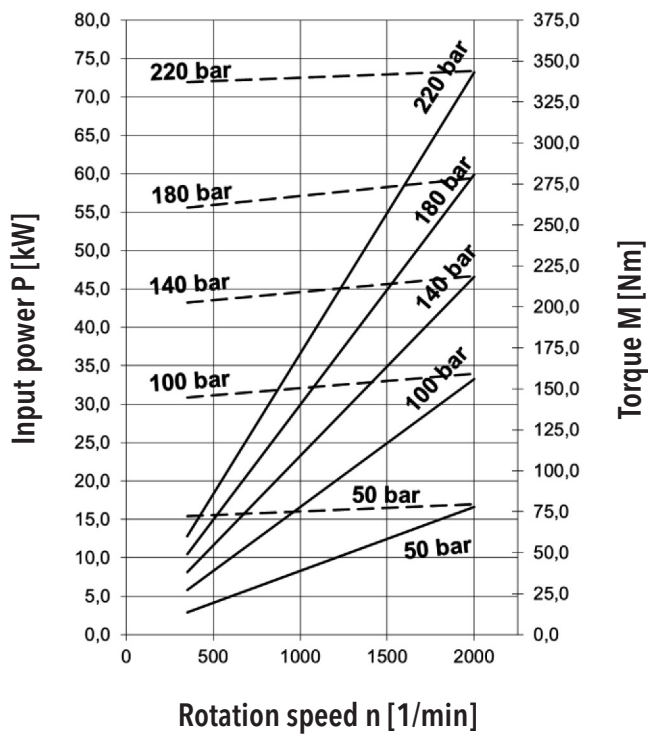







ORDER KEY



QHD1 - 51 R - R11 C11 - S G05 G04 - N . 001









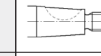

Code	Type
QHD1	QHD1 Series Gear Pump

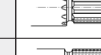



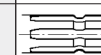
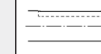

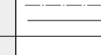











Code	Displacement [cm ³]
10	10,11
17	17,24
27	27,35
31	30,92
34	33,89
43	42,81
51	51,13
61	61,24
71	71,35
81	82,05
XX	Other displacements on request

Code	Direction of rotation
R	Clockwise
L	Anti-clockwise
B	Bi-directional



Code	Flange design
R11	 Rectangular flange, centre ring $\varnothing 50,8$ Spacing screw 98,5 x 128
S03	 SAE B - 2 apertures
S05	 SAE B - 4 apertures
I01	 ISO, centre ring $\varnothing 80$ front end bearing
I02	 ISO, centre ring $\varnothing 80$
U01	 UNI
Z	Special desing

Code	Location of inlets and outlets
S	 Side (in the body)
R	 Axial (in the cover)
C	 Combination

Code	Drive shaft desing
C11	 Taper 1:8
C12	 Taper 1:5
D13	 Grooving SEA 13T
D15	 Grooving SEA 15T
D16	 Grooving 25x1,5 ČSN 014950
D17	 Grooving UNI 221
D18	 Equilateral spline A8x32x36x6 DIN 5462
D19	 Equilateral spline 6 grooves, $\varnothing 20$
D28	 Equilateral spline DIN 9611
V14	 Cylindric SEA $\varnothing 22,225$
V15	 Cylindric $\varnothing 20h7$
V16	 Cylindric $\varnothing 25$
V20	 Cylindric $\varnothing 25,4$
Z	Special desing

Code	Liquid inlet and outlet connection shape
M08	 Thread M 27x1,5
M09	 Thread M 27x2
M11	 Thread M 33x1,5
M12	 Thread M 33x2
M15	 Thread M 48x2
G03	 Thread BSP G1/2
G04	 Thread BSP G3/4
G05	 Thread BSP G1"
G06	 Thread BSP G1 1/4
U04	 Thread 7/8-14 UNF
U05	 Thread 1-1/16-12 UN
U07	 Thread 1-5/16-12 UN
U08	 Thread 1-5/8-12 UN
H08	 Flanged fitting 4xM8 / $\varnothing 40$
H09	 Flanged fitting 4xM8/ $\varnothing 55$; $\varnothing 18$
H10	 Flanged fitting 4xM8/ $\varnothing 55$; $\varnothing 25$
H11	 Flanged fitting 4xM10 / $\varnothing 51$
A02	 Flanged fitting SAE 3/4
A03	 Flanged fitting SAE 1"
A04	Flanged fitting SAE 1 1/4
A05	Flanged fitting SAE 1 1/2
E02	Flanged fitting 3/4
E03	Flanged fitting 1"
E04	Flanged fitting 1 1/4
E05	Flanged fitting 1 1/2
K03	Flanged fitting 4xM8 / $\varnothing 40$; $\varnothing 18$
K04	Flanged fitting 4xM10/ $\varnothing 51$; $\varnothing 26$
K05	Flanged fitting 4xM8 / $\varnothing 55$; $\varnothing 18$
K06	Flanged fitting 4xM8 / $\varnothing 55$; $\varnothing 25$
S08	Flanged fitting 4xM10/22x54
S09	Flanged fitting 4xM10/22x54
S10	Flanged fitting 4xM8/22x46
S11	Flanged fitting 4xM8/22x46
Z	Special desing

Code	Special arrangements
-	No special arrangements
001	Two-edged shaft seal
004	Without shaft seal
007	Rotated fitting
008	With front end bearing light desing
009	Sealed section
012	Axial and radial inlet and outlet
013	Inside drain
014	Axial drain M18x1,5
015	Axial drain M16x1,5
050	Bulit-in bleeder

Code	Seal material
N	 NBR
V	 FKM (VITON)
H	 HNBR

An example of designation for the QHD1 clockwise pump with displacement of 51 cm³, Rectangular flange with centre ring $\varnothing 50,8$, Taper 1:8, BSP side inlets, standard NBR seal and with two-edges shaft seal.: **QHD1 - 51 R - R11C11 - SG05G04 - N.001**

Note: In case of combination inlets, with the code „C” is respected following sequence of inlets and outlets:

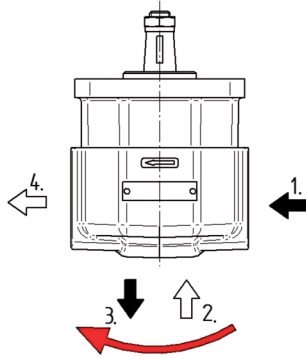

For clockwise and reverse gear pump,
in direction clockwise

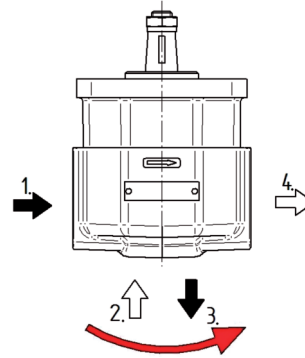

For anti-clockwise gear pump,
in direction anti-clockwise

For. ex....: QHD1-43B-R11C11-CG05 G05 G04 G04 -N
1. 2. 3. 4.

COMBINATIONS OF FLANGES AND SHAFTS

		FLANGE DESIGN						
		R11	R13	S03	S05	I01 / I02	U01	B01
DRIVE SHAFT	C11							
	C12							
	D13							
	D15							
	D17							
	D18							
	D28							
	V14							
	V15							
	V16							
	V20							

FLANGES DESIGN

R11:

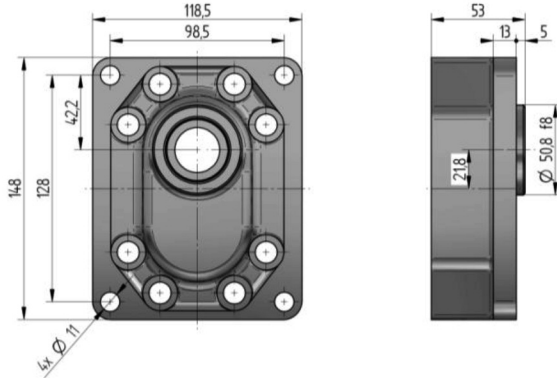

U01:

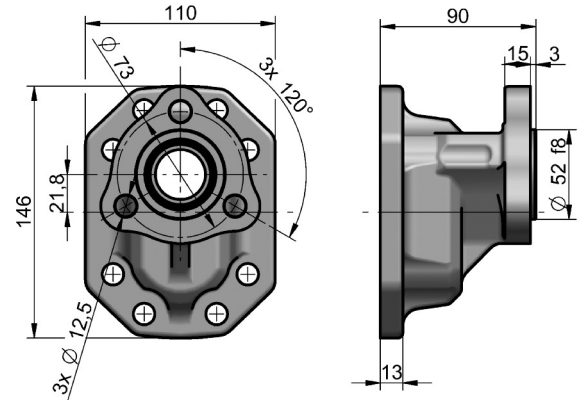

S03:

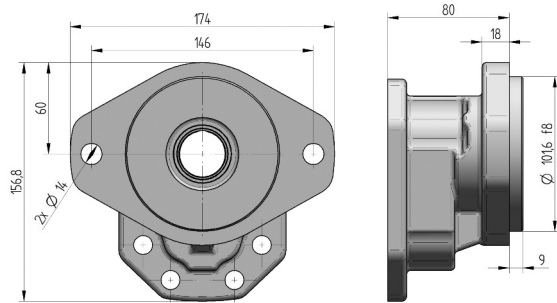

S05:

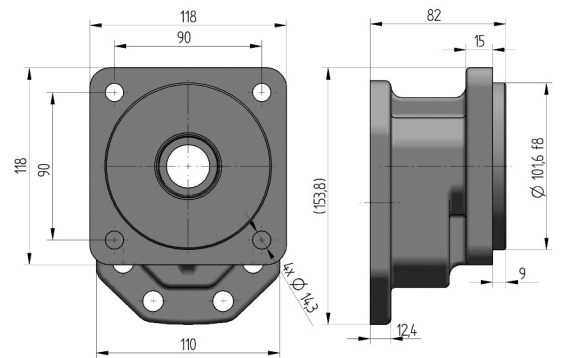

I01:

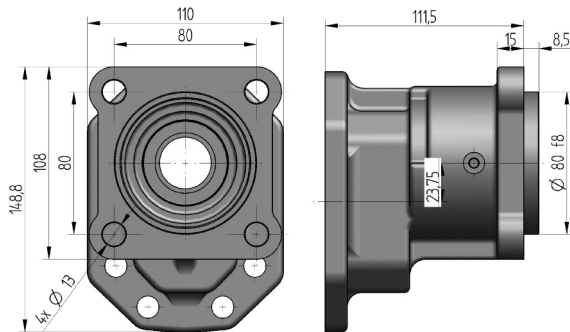

I02:

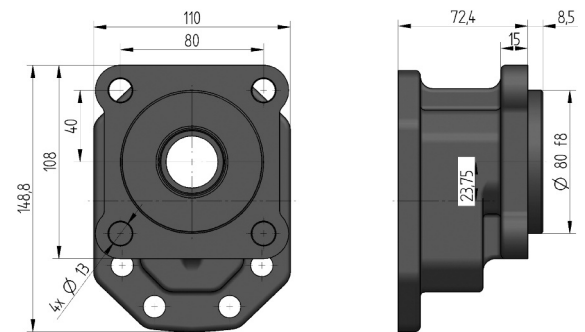

DRIVE SHAFTS

C11:

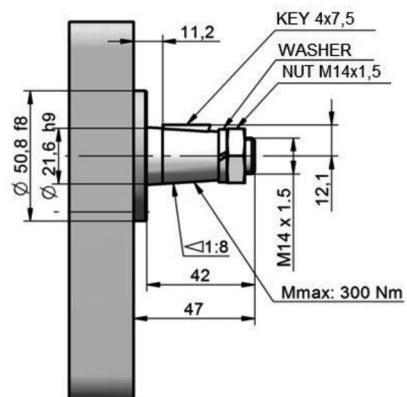

C12:

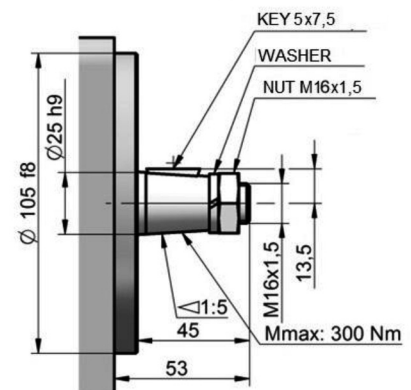

D13:

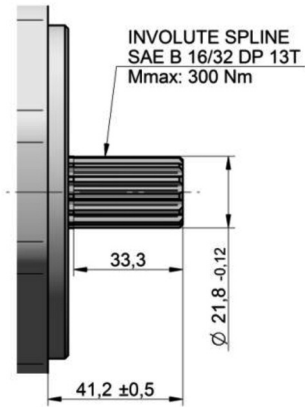

D15:

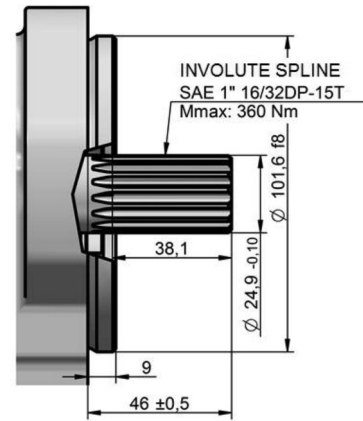

D16:

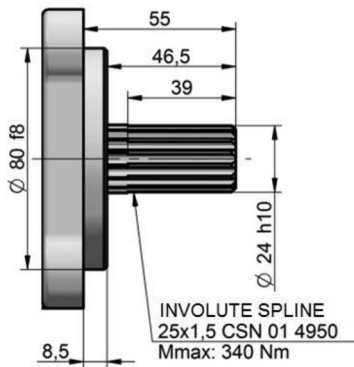

D17:

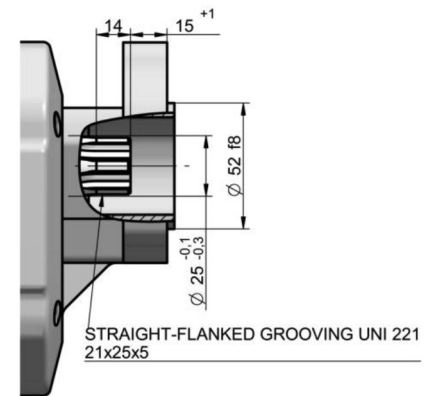

D18:

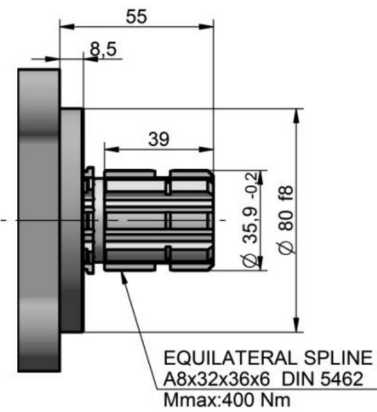

D19:

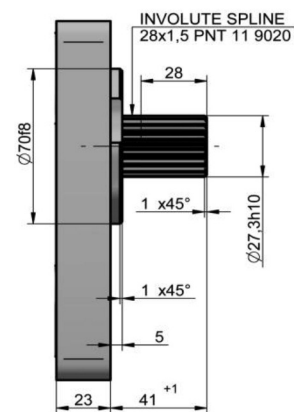

D20:

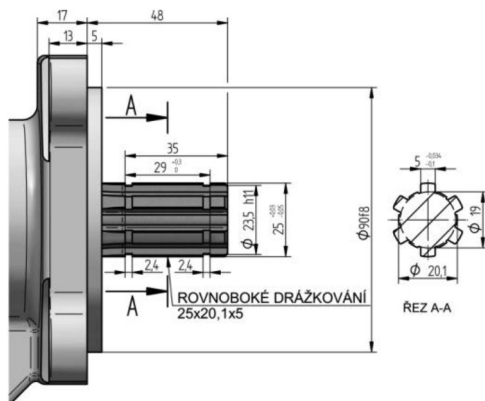

D28:

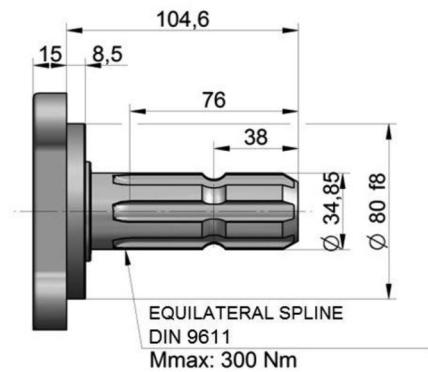

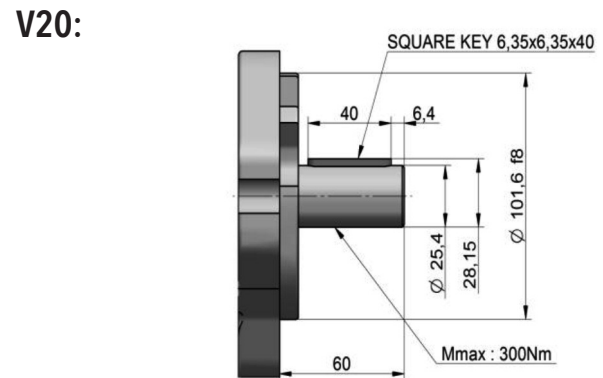
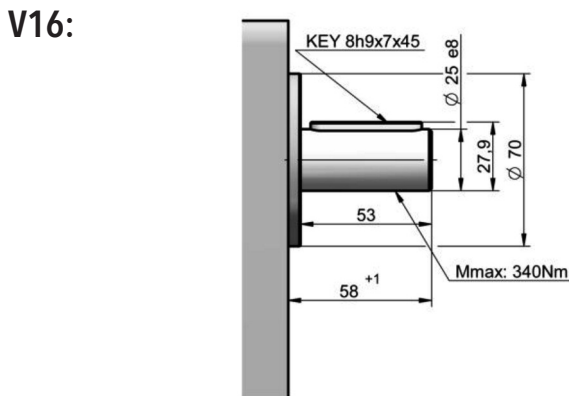
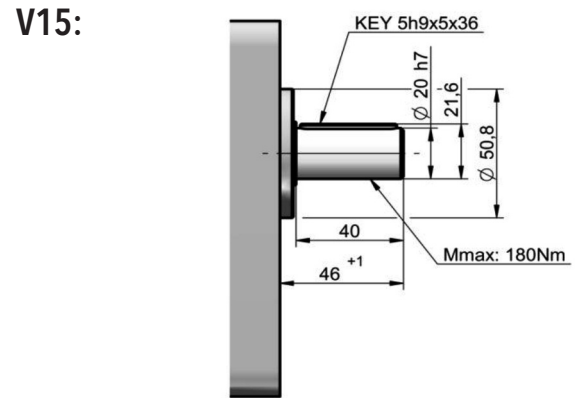
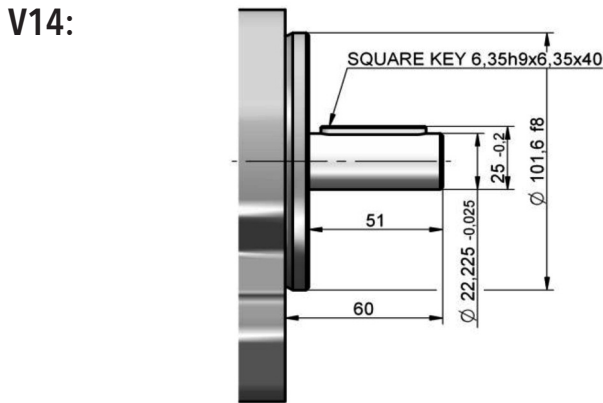

LIQUID INLET AND OUTLET CONNECTION

Metric thread according to ISO 6149

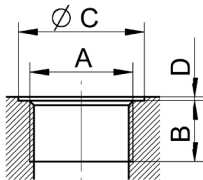

Displacement [cm ³]	Code	Inlet				Code	výstup			
		A	B	C	D		A	B	C	D
to 51 including	M12	M 33x2	18	40	1	M09	M 27x2	16	33	1
above 51	M15	M 48x2	18	56	1	M12	M 33x2	18	40	1

BSP pipe thread according to ISO 228-1

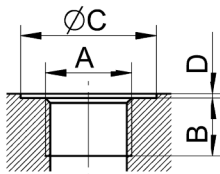

Displacement [cm ³]	Code	Inlet				Code	Outlet			
		A	B	C	D		A	B	C	D
to 17 including	G03	G 1/2"	14	33	1	G03	G 1/2"	14	33	1
17-34 including	G04	G 3/4"	16	39	1	G04	G 3/4"	16	39	1
34-51 including	G05	G 1"	18	45	1	G04	G 3/4"	16	39	1
above 51	G06	G 1 1/4"	20	57	1	G05	G 1"	18	45	1

UNF thread according to SAE

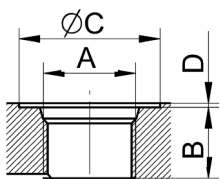

Displacement [cm ³]	Code	Inlet				Code	Outlet			
		A	B	C	D		A	B	C	D
to 17 including	U05	1-1/16-12UNF	19	41	1	U04	7/8-14UNF	17	34	1
17-27 including	U07	1-5/16-12UNF	23	49	1	U05	1-1/16-12UNF	19	41	1
27-39 including	U07	1-5/16-12UNF	23	49	1	U07	1-5/16-12UNF	23	49	1
above 39	U08	1-5/8-12UN-2B	23	58	1	U07	1-5/16-12UNF	23	49	1

Flanged fittings according to DIN 8901/8902

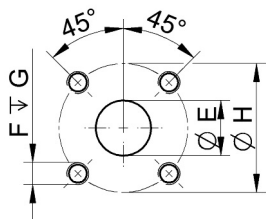

Displacement [cm ³]	Code	Inlet				Code	Outlet			
		E	F	G	H		E	F	G	H
all	H11	26	M10	16	51	H08	18	M8	16	40
all	H10	25	M8	16	55	H09	18	M8	16	55

Flanged fittings according to SAE, metric thread

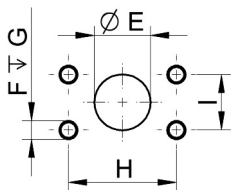

Displacement [cm ³]	Code	Inlet					Code	Outlet				
		E	F	G	H	I		E	F	G	H	I
to 61 including	E03	25.4	M10	22	52.4	26.2	E02	19.0	M10	22	47.6	22.2
above 61	E04	30.5	M10	22	58.7	30.2	E03	25.4	M10	22	52.4	26.2
above 61	E05	39.3	M12	27	69.8	35.7	E04	30.5	M10	22	58.7	30.2

Flanged fittings according to SAE, UNC thread

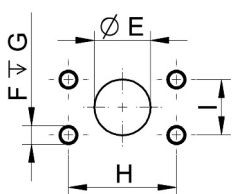

Displacement [cm ³]	Code	Inlet					Code	Outlet				
		E	F	G	H	I		E	F	G	H	I
to 61 including	A03	25.4	3/8-16 UNC	22	52.4	26.2	A02	19.0	3/8-16 UNC	22	47.6	22.2
above 61	A04	30.5	7/16-14 UNC	29	58.7	30.2	A03	25.4	3/8-16 UNC	22	52.4	26.2
above 61	A05	39.3	1/2-13 UNC	27	69.8	35.7	A04	30.5	7/16-14 UNC	29	58.7	30.2

Flanged fittings - „cross“

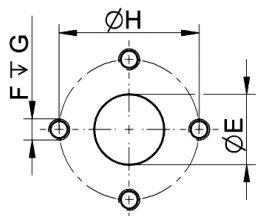

Displacement [cm ³]	Code	Inlet				Code	Outlet			
		E	F	G	H		E	F	G	H
all	K04	26	M10	16	51	K03	18	M8	16	40
all	K06	25	M8	16	55	K05	18	M8	16	55

Flanged fittings - „square“

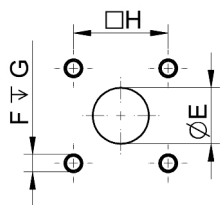

Displacement [cm ³]	Code	Inlet				Code	Outlet			
		E	F	G	H		E	F	G	H
to 43 including	S11	23	M8	22	46	S10	16	M8	22	46
above 43	S09	27	M10	22	54	S08	19	M10	22	54

Drains:

Displacement [cm ³]	Code	Outlet			
		A	B	C	D
all	M04	M 16 x 1.5	14	22	1
	M05	M 18 x 1.5	14	24	1
	G01	G 1/4"	13	18	1
	G02	G 3/8"	13	24	1
	G03	G 1/2"	14	33	1
	U02	9/16-18UNF	14	25	1

CATALOGUE SHETS OF QHD1 SERIES BASIC DESIGNS

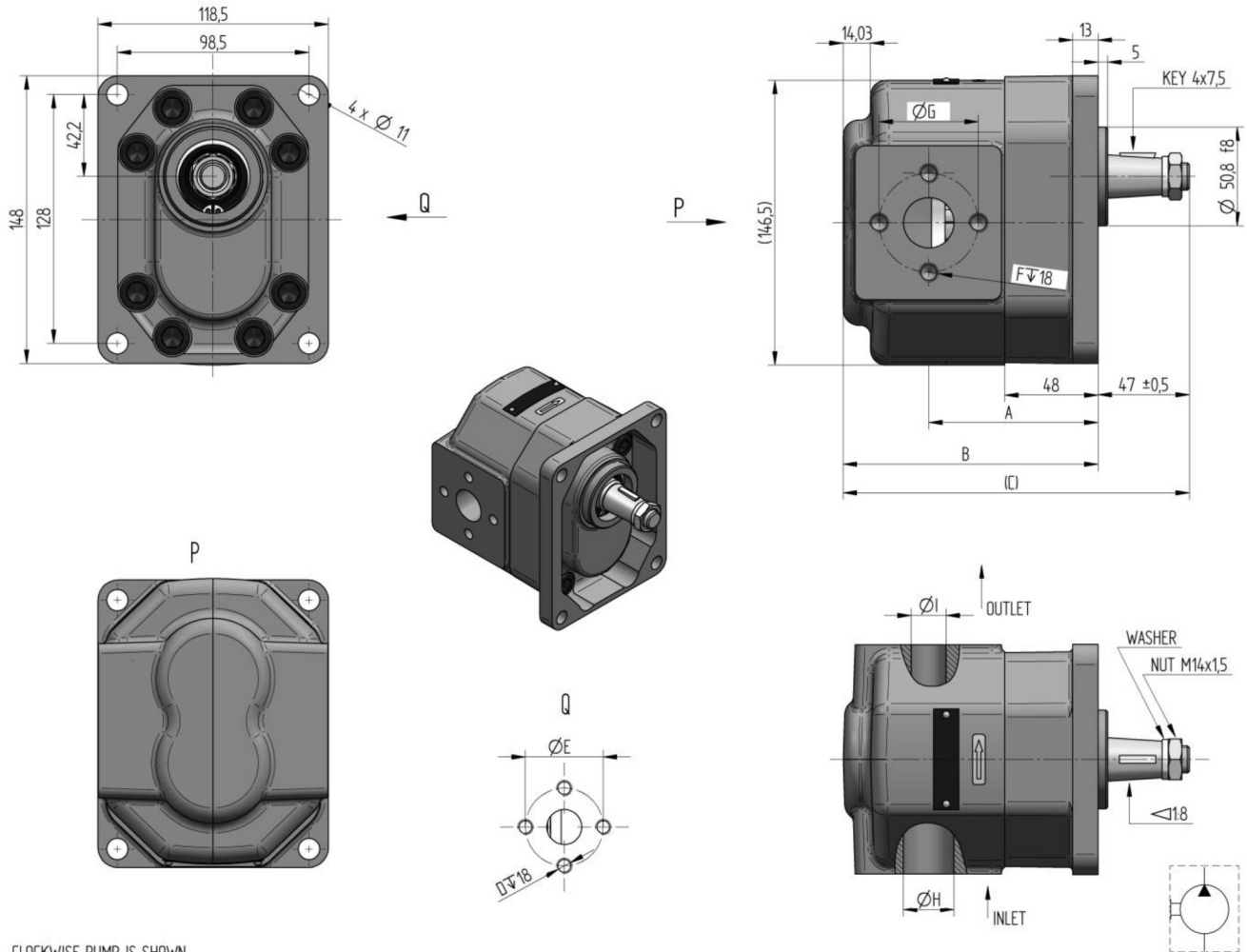

CLOCKWISE PUMP IS SHOWN

Order key	purch. code	direct. of rot.	displacement [cm ³ /1]	nom. press. [bar]	speed MIN. [min ⁻¹]	speed MAX. [min ⁻¹]	dimension								
							A [mm]	B [mm]	C [mm]	D [mm]	ØE [mm]	F [mm]	ØG [mm]	ØH [mm]	ØH [mm]
QHD1-51R- R11C11-SK06K05-N		R	51	240	350	2600	110,5	150,5	197,5	M8	55	M8	55	25	18
QHD1-51L- R11C11-SK06K05-N		L													
QHD1-43R- R11C11-SK06K05-N		R	43	270	350	2700	105,0	145,0	192,0	M8	55	M8	55	25	18
QHD1-43L- R11C11-SK06K05-N		L													
QHD1-34R- R11C11-SK06K05-N		R	34	280	350	3000	98,5	138,5	185,5	M8	55	M8	55	25	18
QHD1-34L- R11C11-SK06K05-N		L													
QHD1-27R- R11C11-SK06K05-N		R	27	300	350	3200	94,0	134,0	181,0	M8	55	M8	55	25	18
QHD1-27L- R11C11-SK06K05-N		L													
QHD1-17R- R11C11-SK06K05-N		R	17	290	350	3200	87,0	127,0	174,0	M8	55	M8	55	25	18
QHD1-17L- R11C11-SK06K05-N		L													
QHD1-10R- R11C11-SK06K05-N		R	10	290	350	3200	82,0	122,0	169,0	M8	55	M8	55	25	18
QHD1-10L- R11C11-SK06K05-N		L													

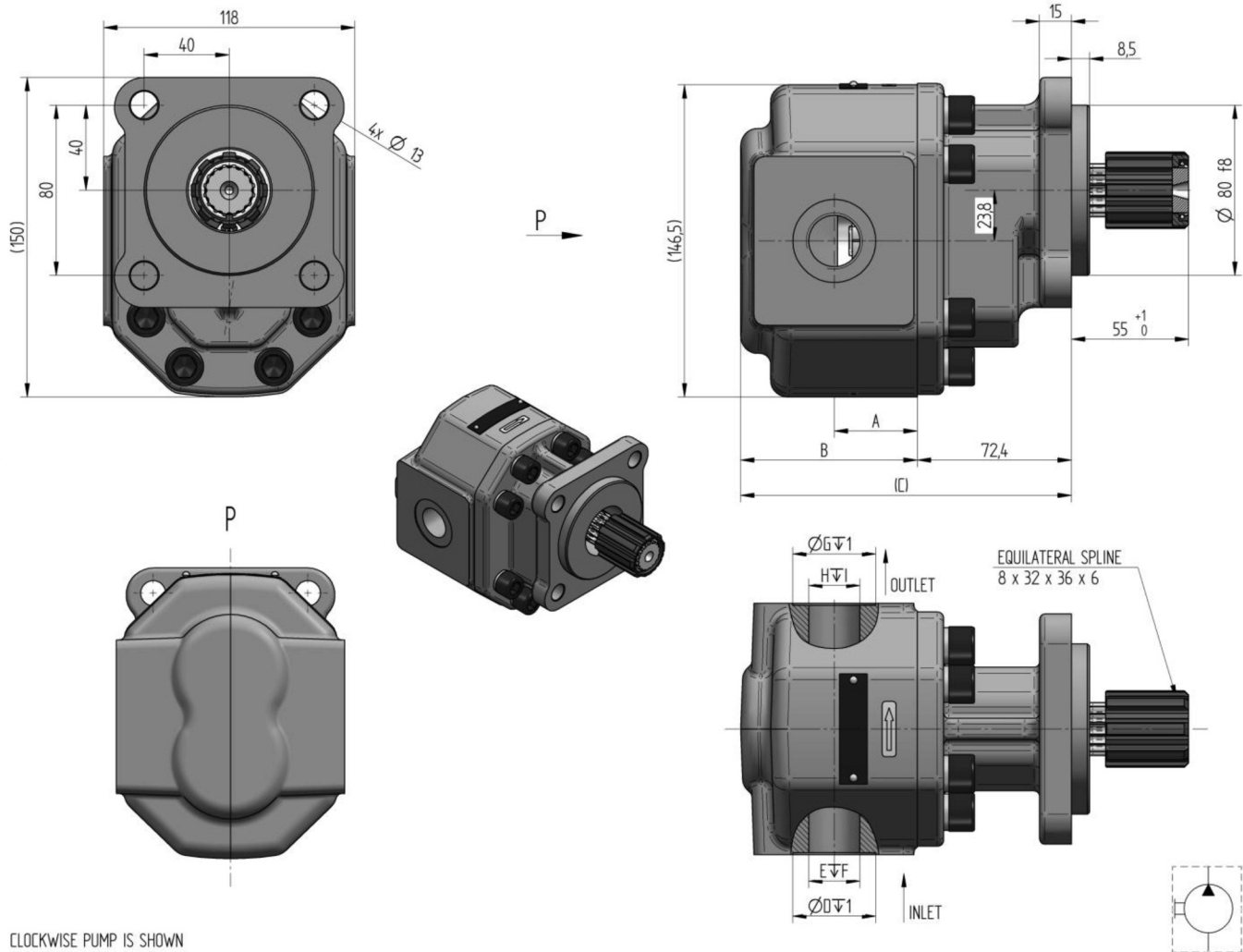

Order key	purch. code	direct. of rot.	displacement [cm ³ /1]	nom. press. [bar]	speed MIN. [min ⁻¹]	speed MAX. [min ⁻¹]	dimension								
							A [mm]	B [mm]	C [mm]	ØD [mm]	E [mm]	F [mm]	ØG [mm]	H [mm]	I [mm]
QHD1-71R- I02D18-SG05G04-N		R	71	230	350	2200	65	104,0	176,4	45	G1"	18	39	G3/4"	16
QHD1-71L- I02D18-SG05G04-N		L													
QHD1-61R- I02D18-SG05G04-N	1889111	R	61	260	350	2400	63	100,5	172,9	45	G1"	18	39	G3/4"	16
QHD1-61L- I02D18-SG05G04-N	1889114	L													
QHD1-51R- I02D18-SG05G04-N	1889110	R	51	260	350	2600	55	92,5	164,9	45	G1"	18	39	G3/4"	14
QHD1-51L- I02D18-SG05G04-N	1889113	L													
QHD1-43R- I02D18-SG05G04-N		R	43	280	350	2800	50	87,0	159,4	45	G1"	18	39	G3/4"	14
QHD1-43L- I02D18-SG05G04-N		L													
QHD1-34R- I02D18-SG04G04-N	1889109	R	34	300	350	3000	42	80,5	152,9	39	G3/4"	16	39	G3/4"	16
QHD1-34L- I02D18-SG04G04-N	1889112	L													
QHD1-27R- I02D18-SG04G03-N		R	27	300	350	3200	39	76,5	148,9	39	G3/4"	16	33	G1/2"	14
QHD1-27L- I02D18-SG04G03-N		L													
QHD1-17R- I02D18-SG03G03-N		R	17	300	350	3200	32	68,5	140,9	33	G1/2"	14	33	G1/2"	14
QHD1-17L- I02D18-SG03G03-N		L													
QHD1-10R- I02D18-SG03G03-N		R	10	290	350	3200	30	64,0	136,4	33	G1/2"	14	33	G1/2"	14
QHD1-10L- I02D18-SG03G03-N		L													

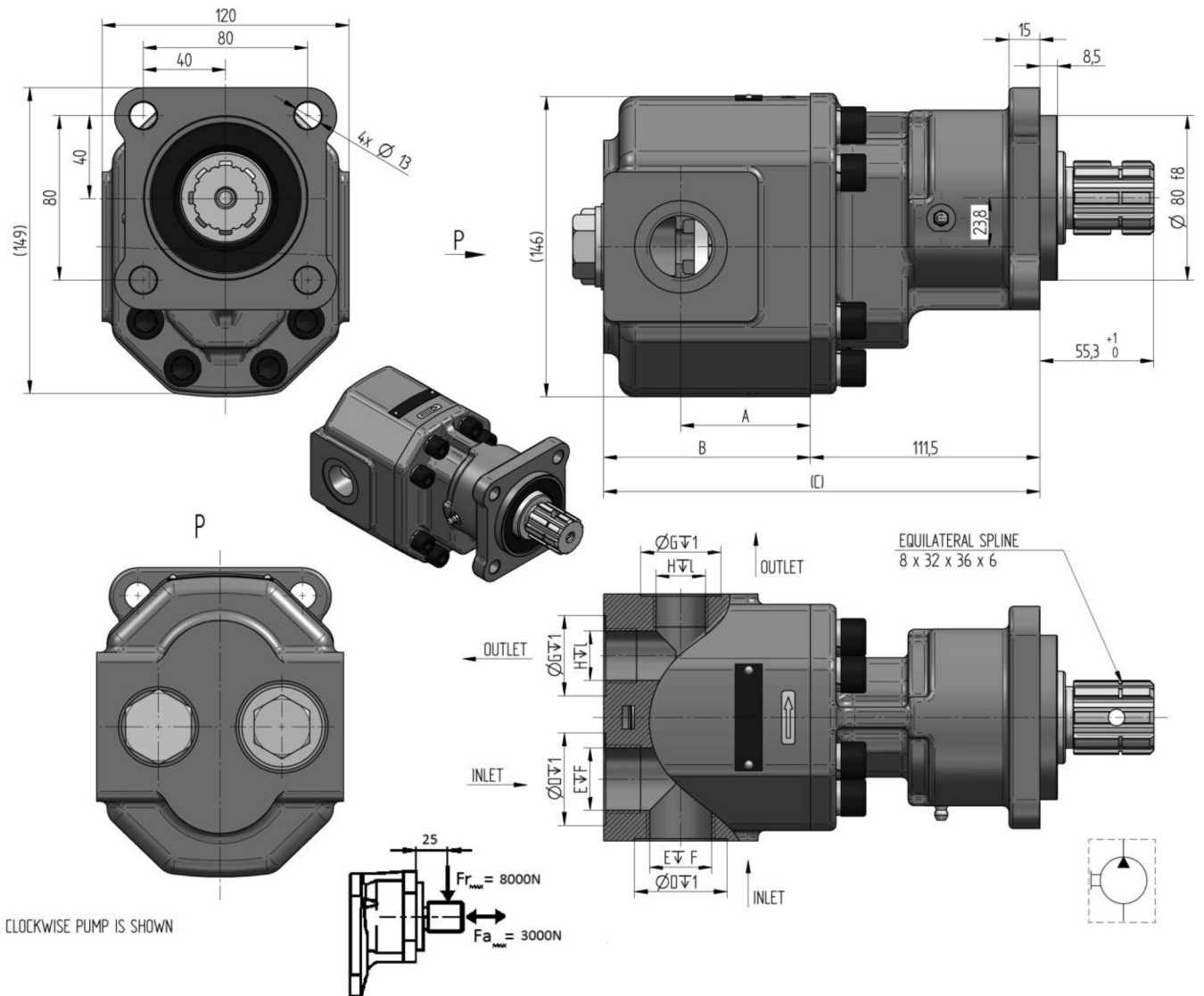

CLOCKWISE PUMP IS SHOWN

Order key	purch. code	direct. of rot.	displacement [cm ³ /1]	nom. press. [bar]	speed MIN. [min ⁻¹]	speed MAX. [min ⁻¹]	dimension								
							A [mm]	B [mm]	C [mm]	ØD [mm]	E [mm]	F [mm]	ØG [mm]	H [mm]	I [mm]
QHD1-71R-I01D18-CG05G05G04G04-N		R	71	230	350	2200	65	104,0	215,5	45	G 1"	18	39	G 3/4"	16
QHD1-71L-I01D18-CG05G05G04G04-N		L													
QHD1-61R-I01D18-CG05G05G04G04-N	1889119	R	61	260	350	2400	63	100,5	212,0	45	G 1"	18	39	G 3/4"	16
QHD1-61L-I01D18-CG05G05G04G04-N	1889118	L													
QHD1-51R-I01D18-CG05G05G04G04-N		R	51	260	350	2600	55	92,5	204,0	45	G 1"	18	39	G 3/4"	16
QHD1-51L-I01D18-CG05G05G04G04-N		L													
QHD1-43R-I01D18-CG05G05G04G04-N		R	43	280	350	2800	50	87,0	198,5	45	G 1"	18	39	G 3/4"	16
QHD1-43L-I01D18-CG05G05G04G04-N	1889117	L													
QHD1-34R-I01D18-CG04G04G04G04-N		R	34	300	350	3000	42	80,5	192,0	39	G 3/4"	16	39	G 3/4"	16
QHD1-34L-I01D18-CG04G04G04G04-N		L													
QHD1-27R-I01D18-CG04G04G04G04-N		R	27	300	350	3200	39	76,5	188,0	39	G 3/4"	16	33	G 1/2"	14
QHD1-27L-I01D18-CG04G04G04G04-N		L													
QHD1-17R-I01D18-CG03G03G03G03-N		R	17	300	350	3200	32	68,5	180,0	33	G 1/2"	14	33	G 1/2"	14
QHD1-17L-I01D18-CG03G03G03G03-N		L													
QHD1-10R-I01D18-CG03G03G03G03-N		R	10	290	350	3200	30	64,0	175,5	33	G 1/2"	14	33	G 1/2"	14
QHD1-10L-I01D18-CG03G03G03G03-N		L													

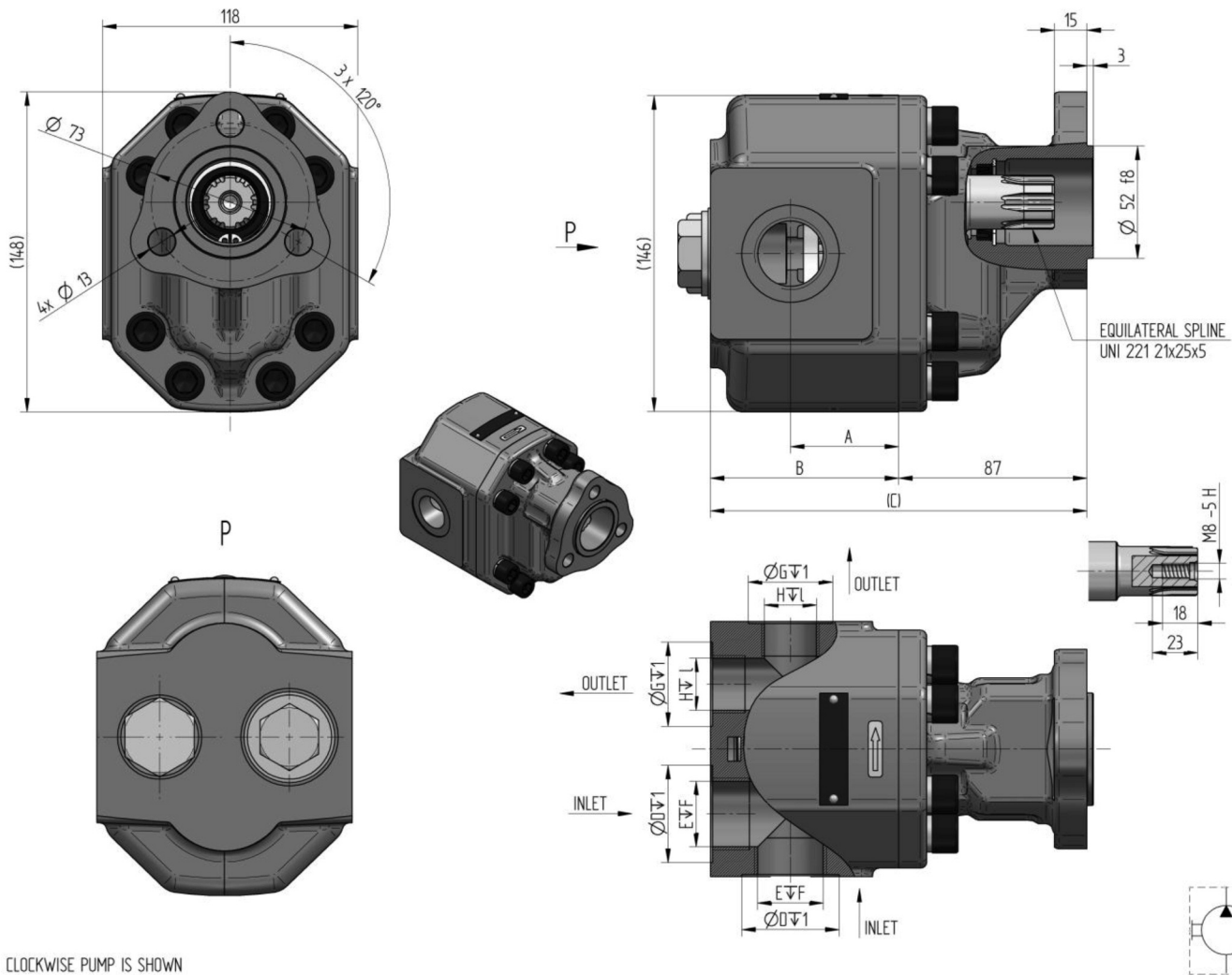

CLOCKWISE PUMP IS SHOWN

Order key	purch. code	direct. of rot.	displacement [cm ³ /1]	nom. press. [bar]	speed MIN. [min ⁻¹]	speed MAX. [min ⁻¹]	dimension								
							A [mm]	B [mm]	C [mm]	ØD [mm]	E [mm]	F [mm]	ØG [mm]	H [mm]	I [mm]
QHD1-71R-U01D17-CG05G05G04G04-N		R	71	230	350	2200	65	104,0	194,0	45	G 1"	18	39	G3/4"	16
QHD1-71L-U01D17-CG05G05G04G04-N		L													
QHD1-61R-U01D17-CG05G05G04G04-N	1889104	R	61	260	350	2400	63	100,5	190,5	45	G 1"	18	39	G3/4"	16
QHD1-61L-U01D17-CG05G05G04G04-N	1889108	L													
QHD1-51R-U01D17-CG05G05G04G04-N	1889103	R	51	260	350	2600	55	92,5	182,5	45	G 1"	18	39	G3/4"	16
QHD1-51L-U01D17-CG05G05G04G04-N	1889107	L													
QHD1-43R-U01D17-CG05G05G04G04-N		R	43	280	350	2800	50	87,0	177,0	45	G 1"	18	39	G3/4"	16
QHD1-43L-U01D17-CG05G05G04G04-N		L													
QHD1-34R-U01D17-CG04G04G04G04-N	1889102	R	34	300	350	3000	42	80,5	170,5	39	G3/4"	16	39	G3/4"	16
QHD1-34L-U01D17-CG04G04G04G04-N	1889106	L													
QHD1-27R-U01D17-CG04G04G04G04-N	1889101	R	27	300	350	3200	39	76,5	166,5	39	G3/4"	16	33	G1/2"	14
QHD1-27L-U01D17-CG04G04G04G04-N		L													
QHD1-17R-U01D17-CG03G03G03G03-N	1889100	R	17	300	350	3200	32	68,5	158,5	33	G1/2"	14	33	G1/2"	14
QHD1-17L-U01D17-CG03G03G03G03-N	1889105	L													
QHD1-10R-U01D17-CG03G03G03G03-N		R	10	290	350	3200	30	64,0	154,0	33	G1/2"	14	33	G1/2"	14
QHD1-10L-U01D17-CG03G03G03G03-N		L													

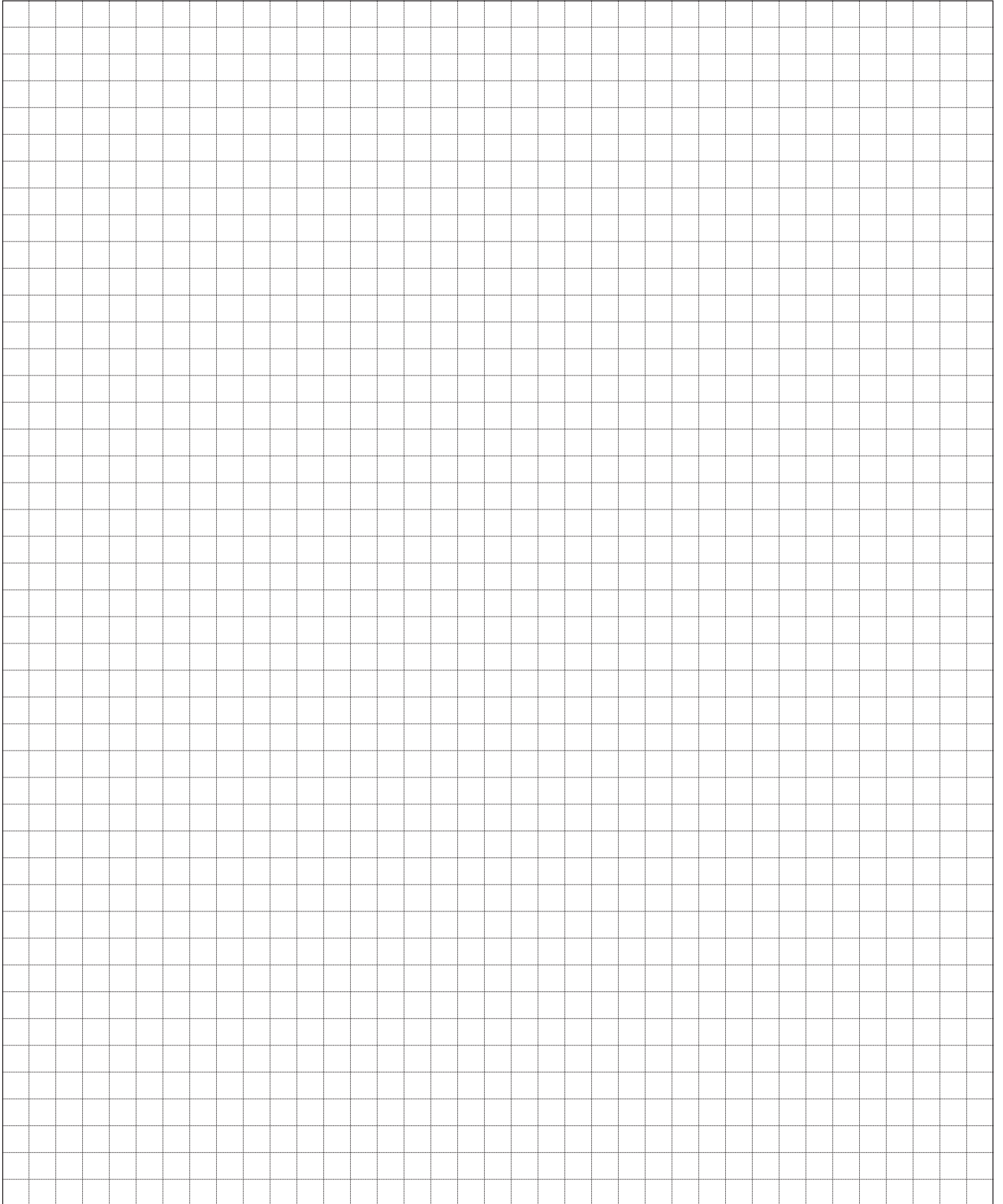

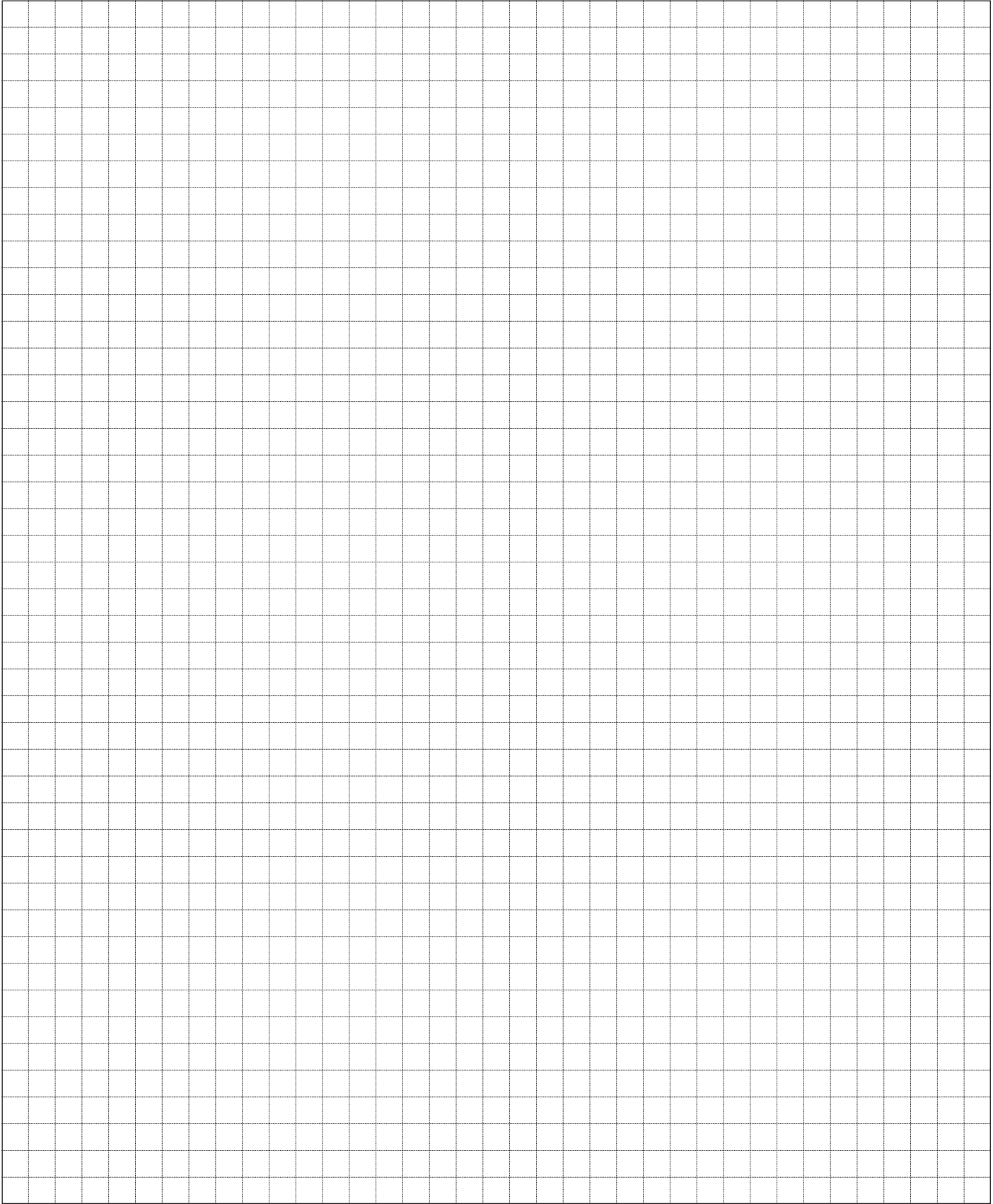

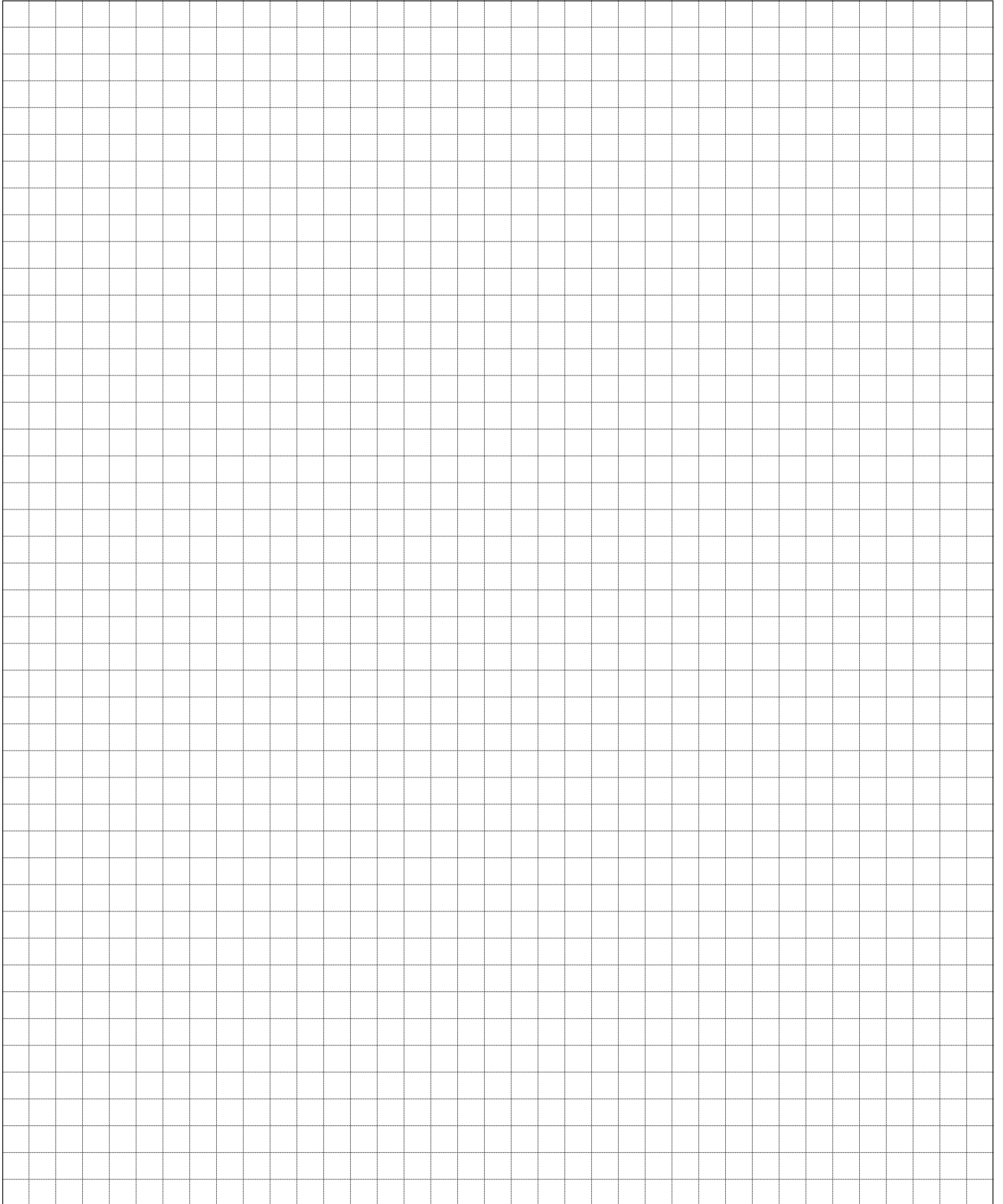

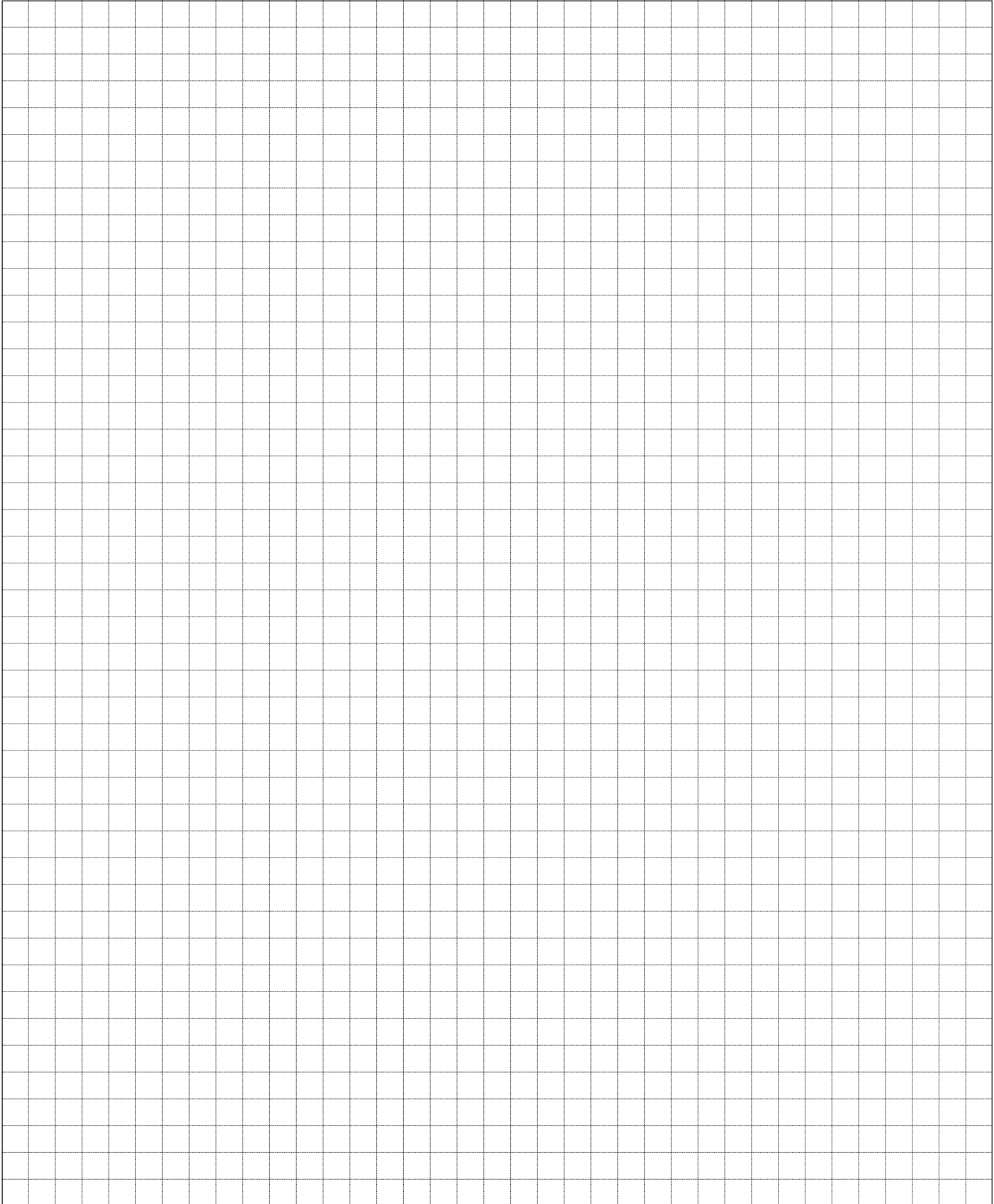

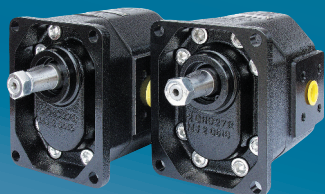
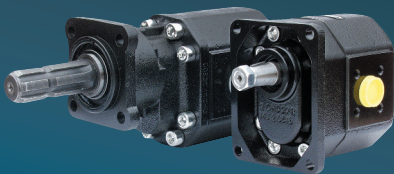

jihostroj
AERO TECHNOLOGY & HYDRAULICS

JIHOSTROJ a.s.
Budějovická 148
CZ 382 32 Velešín
Czech Republic
tel.: +420 380 340 511
fax: +420 380 340 612
e-mail: mailbox@jihostroj.cz
http: //www.jihostroj.com

GPS 48°49'51.748" N 14°27'40.770" E

