

juhstroj

AERO TECHNOLOGY & HYDRAULICS

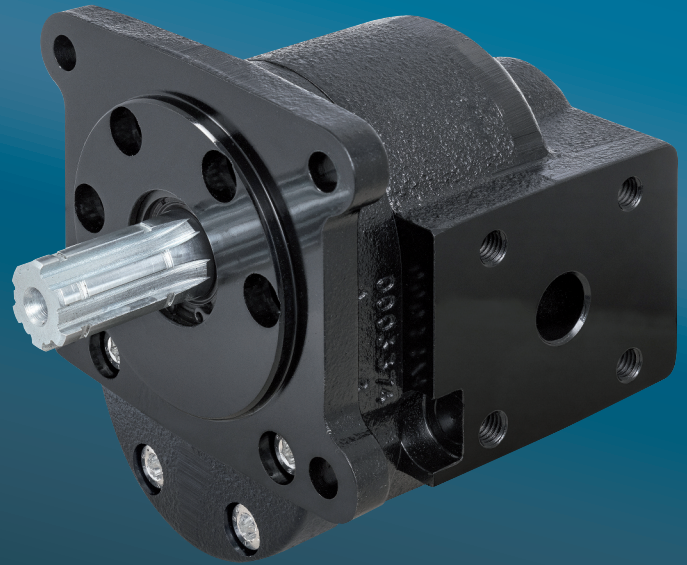
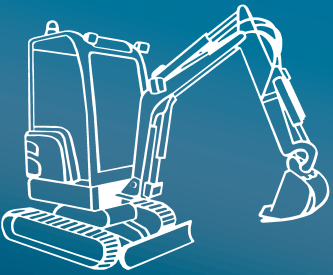

Displacement from 7 to 51 ccm
Pressure up to 260 bar
Speed from 350 to 3400 RPM

GEAR PUMPS

QHDO

TABLE OF CONTENTS

DESCRIPTION.....	2
BASIC PARTS OF PUMP.....	2
PARAMETER TABLE.....	3
FORMULAS USED FOR CALCULATION.....	4
PUMP EFFICIENCIES.....	4
WORKING LIQUID.....	5
PRESSURE LOAD.....	5
OTHER REQUIREMENTS.....	6
DIRECTION OF ROTATION.....	6
REVERSIBLE DESIGN.....	6
QHDO FLOW RATE AND POWER CURVES.....	7
ORDER KEY.....	11
COMBINATIONS OF FLANGES AND SHAFTS.....	12
FLANGES DESIGN.....	13
DRIVE SHAFTS.....	14
LIQUID INLET AND OUTLET CONNECTION.....	15
CATALOGUE SHETS OF QHDO SERIES BASIC DESIGNS.....	17
NOTES.....	22

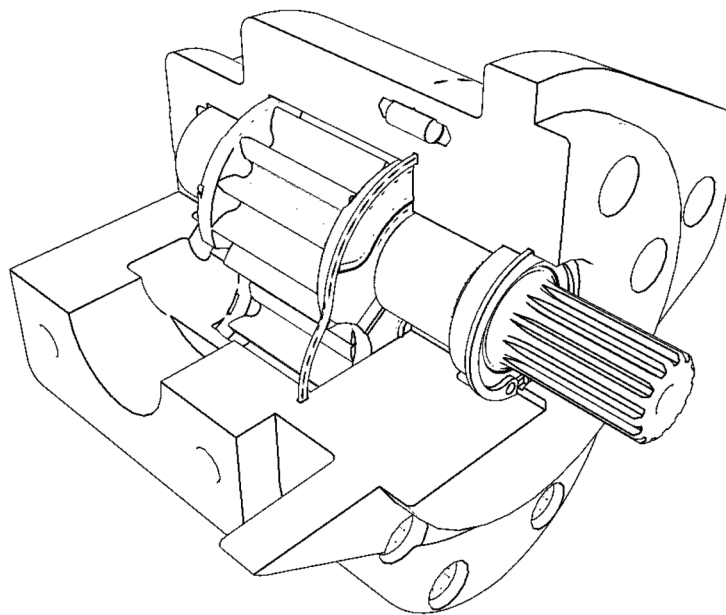

DESCRIPTION

- Due to their robust iron-cast structure, the QHDO series pumps with external gearing are intended for the heaviest applications in the area of agricultural and building machines. The QHDO series covers the range of displacements from 7 to 56 cm³/rev.
- The pumps are characterized by simple construction with hydraulic pressure balance, compact dimensions and a wide range of connection types. QHDO pumps have a two-piece all-cast-iron construction. The basis consists of a supporting body with a blind chamber for gear wheels and a fastening flange. The body as well as the flange are made of a high-quality grey cast iron. In the body and the flange, sliding sleeves for gear wheels are molded. Gear wheels with 13 teeth made of ultra high-strength steel, which are optimised to achieve a low noise level. The axial pump balancing is performed using sliding aluminium alloy pressure plates in which a shape sealing of balancing surface is located in grooves. QHDO construction enables the pumps to be used already at low revolutions at high pressure.
- The QHDO pumps are produced in various designs of drives, clamping flanges as well as liquid inlets and outlets. These pumps comply with the standards ISO, SAE, UNI and other world-recognised standards. They can also be delivered in a reversible design, with external or internal drainage.

BASIC PARTS OF PUMP

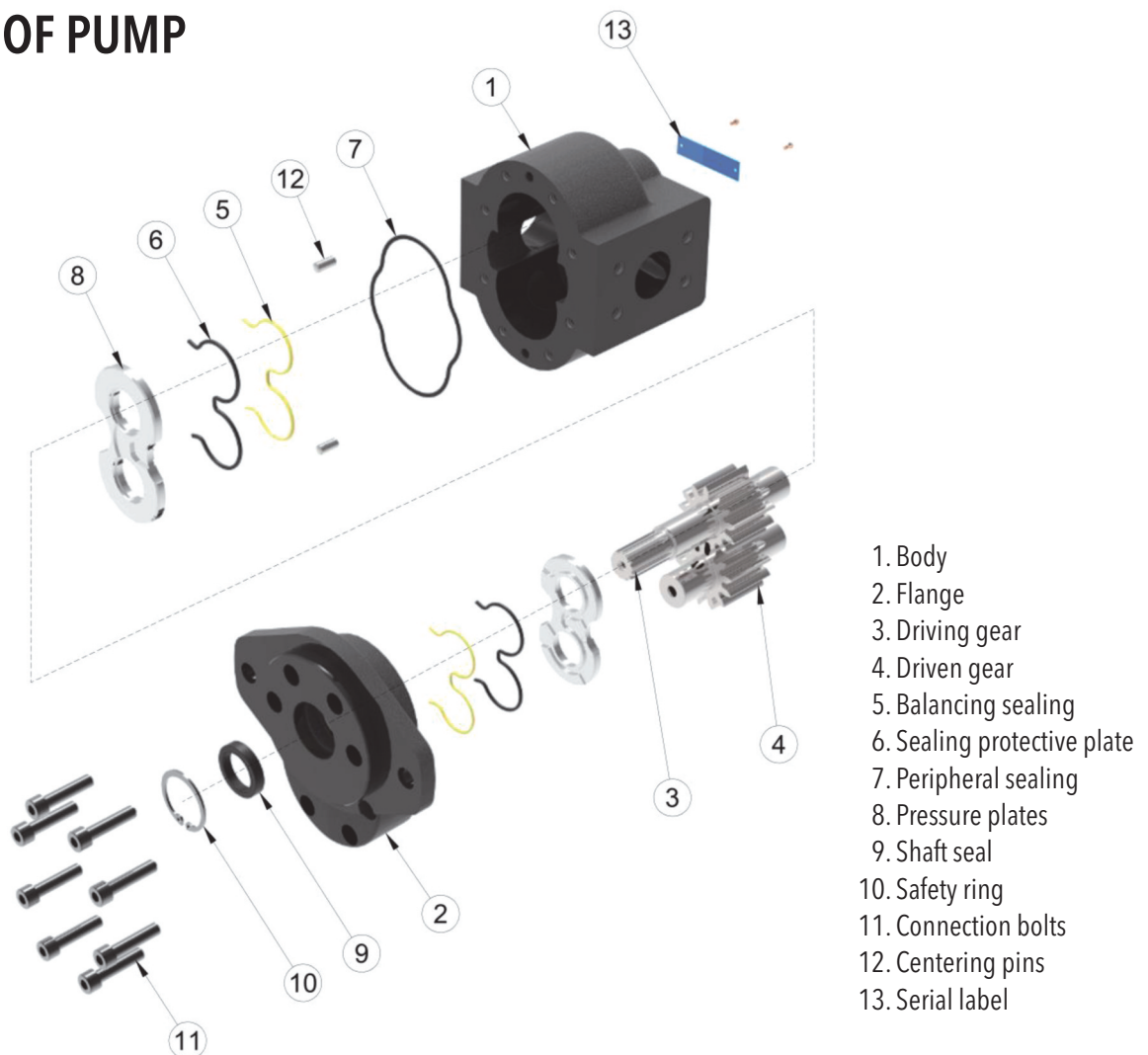

PARAMETER TABLE

Nominal Size Parameters	Sym.	Unit.	QHDO 7	QHDO 10	QHDO 13	QHDO 17	QHDO 19	QHDO 23	QHDO 27
Actual displacement	V_g	[cm ³]	7.21	9.71	12.85	17.31	19.41	22.95	27.54
Rotation speed	nominal	n_n	[min ⁻¹]	1500	1500	1500	1500	1500	1500
	minimum	n_{min}	[min ⁻¹]	400	400	400	350	350	350
	maximum	n_{max}	[min ⁻¹]	3400	3400	3400	3400	3400	3400
Pressure at inlet*	minimum	p_{1min}	[bar]	-0.4	-0.4	-0.4	-0.4	-0.4	-0.4
	maximum	p_{1max}	[bar]	0.6	0.6	0.6	0.6	0.6	0.6
Pressure at outlet**	max. continuous	p_{2n}	[bar]	240	240	240	240	235	230
	maximum	p_{2max}	[bar]	260	260	260	260	255	250
	peak	p_3	[bar]	270	270	270	270	265	260
Nominal flow rate (min.) at n_n and p_{2n}	Q_n	[dm ³ .min ⁻¹]	9.9	13.5	18.1	24.4	27.4	32.4	38.8
Maximum flow rate at n_{max} a p_{2max}	Q_{max}	[dm ³ .min ⁻¹]	22.6	30.7	41.1	55.3	62.0	73.3	88.0
Nominal input power (max.) at n_n and p_{2n}	P_n	[kW]	5.3	7.0	9.2	12.4	13.6	16.1	18.9
Maximum input power at n_{max} a p_{2max}	P_{max}	[kW]	13.0	17.2	22.5	30.4	33.4	39.5	46.4
Weight	m	[kg]							

Nominal Size Parameters	Sym.	Unit.	QHDO 29	QHDO 32	QHDO 36	QHDO 38	QHDO 41	QHDO 44	QHDO 51
Actual displacement	V_g	[cm ³]	29.64	32.66	36.72	38.82	41.84	44.99	52.07
Rotation speed	nominal	n_n	[min ⁻¹]	1500	1500	1500	1500	1500	1500
	minimum	n_{min}	[min ⁻¹]	350	350	350	350	350	350
	maximum	n_{max}	[min ⁻¹]	3300	3200	3100	3000	2900	2500
Pressure at inlet*	minimum	p_{1min}	[bar]	-0.4	-0.4	-0.4	-0.4	-0.4	-0.4
	maximum	p_{1max}	[bar]	0.6	0.6	0.6	0.6	0.6	0.6
Pressure at outlet**	max. continuous	p_{2n}	[bar]	230	220	220	215	215	210
	maximum	p_{2max}	[bar]	250	240	240	235	235	230
	peak	p_3	[bar]	260	250	250	245	245	240
Nominal flow rate (min.) at n_n and p_{2n}	Q_n	[dm ³ .min ⁻¹]	41.8	46.1	51.8	54.7	59.0	63.4	73.4
Maximum flow rate at n_{max} a p_{2max}	Q_{max}	[dm ³ .min ⁻¹]	91.9	98.2	107.0	109.5	114.1	118.4	122.4
Nominal input power (max.) at n_n and p_{2n}	P_n	[kW]	20.3	21.4	24.0	24.8	26.8	28.1	32.5
Maximum input power at n_{max} a p_{2max}	P_{max}	[kW]	48.5	49.8	54.2	54.3	56.6	57.5	59.4
Weight	m	[kg]							

* Inlet pressure in the reversible design can be up to $p_1 = p_{2n} - 70$ bar max. External drainage must be used in case of the reversible design.

** Outlet pressure in the reversible design is **10% lower** than shown in the table (depending on operating conditions - it is necessary to consult with the manufacturer).

FORMULAS USED FOR CALCULATION

Flow rate
 Q

$$Q = \frac{V_g \cdot n}{1000} \cdot \eta_v \quad [\text{dm}^3 \cdot \text{min}^{-1}]$$

V_g [cm³] pump displacement
 n [min⁻¹] rotation speed
 η_v [-] volumetric efficiency

Displacement
 V_g

$$V_g = \frac{Q \cdot 1000}{n \cdot \eta_v} \quad [\text{cm}^3]$$

Torque
 M_k

$$M_k = \frac{V_g \cdot p}{20 \cdot \pi \cdot \eta_m} \quad [\text{Nm}]$$

p [bar] required pressure at outlet
 η_m [-] mechanical efficiency

Input power
 P

$$P = \frac{V_g \cdot n \cdot p}{600 \cdot 1000 \cdot \eta_t} \quad [\text{kW}]$$

η_t [-] total efficiency

PUMP EFFICIENCIES

Volumetric efficiency

η_v

It determines the amount of flow losses. Its value is $\eta_v = 0,92 \div 0,98$ (depending on rotation speed, viscosity of working liquid and outlet pressure). It can be expressed as follows:

$$\eta_v = \frac{Q_{act.}}{Q_{theor}} \quad [-]$$

$Q_{act.}$ [dm³ · min⁻¹] actual flow rate
 Q_{theor} [dm³ · min⁻¹] theoretical flow rate

Mechanical efficiency

η_m

It determines mechanical losses. Its value is about $\eta_m = 0,85$. It can be expressed as follows:

$$\eta_m = \frac{M_{theor}}{M_{act.}} \quad [-]$$

$M_{act.}$ [Nm] actual torque
 M_{theor} [Nm] theoretical torque

Total efficiency

η_t

t is defined as product of η_n and η_m and determines difference between theoretical and actual required input power:

$$\eta_t = \eta_v \cdot \eta_m = \frac{P_{theor}}{P_{act.}} \quad [-]$$

$P_{act.}$ [kW] actual input power
 P_{theor} [kW] theoretical input power

WORKING LIQUID

- Mineral oils for hydraulic drives
- Hydraulic liquids based on plant oils suitable for hydraulic drives

Liquid temperature

- $t = -20 \div +80$ [°C]
when used with FKM (Viton) seal up to 120 [°C]

Cinematic viscosity

- Recommended (during continuous operation): $\nu = 20 \div 80 \cdot 10^{-6} [\text{m}^2 \cdot \text{s}^{-1}]$
- Maximum (cold starting, at viscosity >1000 , operating pressure <10 bar is permissible, speed $<1500 \cdot \text{min}^{-1}$): $\nu = 1200 \cdot 10^{-6} [\text{m}^2 \cdot \text{s}^{-1}]$
- Minimum (operating mode at $10 \cdot 10^{-6}$ up $20 \cdot 10^{-6}$ should be consulted with manufacturer): $\nu = 10 \cdot 10^{-6} [\text{m}^2 \cdot \text{s}^{-1}]$

Filtration coefficient β_α

$\beta_{25\ 75} \geq$ (for pressure $p_2 < 200$ bar)
 $\beta_{10\ 75} \geq$ (for pressure $p_2 > 200$ bar)

Liquid contamination class according to ISO 4406

21/18/15 (for pressure $p_2 < 200$ bar)
20/17/14 (for pressure $p_2 > 200$ bar)

Liquid contamination class according to NAS 1638

10 (for pressure $p_2 < 200$ bar)
8 (for pressure $p_2 > 200$ bar)

PRESSURE LOAD

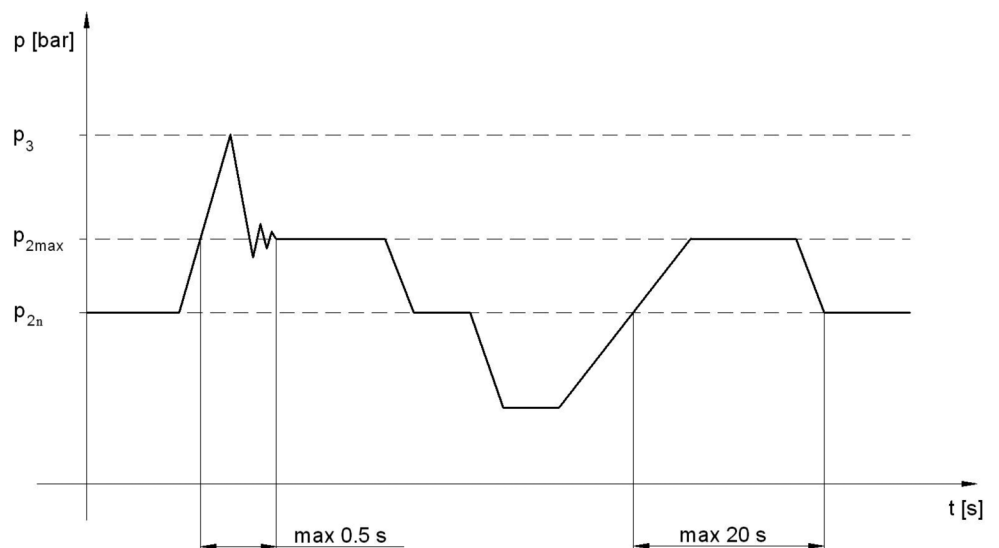

- p_{2n} **max. contin. pressure** Max. working pressure, at which the pump can be operated without time limitation.
- p_{2max} **max. pressure** Maximum pressure permissible for a short time, max. 20s.
- p_3 **peak pressure** Short-time pressure (fractions of a second) arising in case of a sudden change of the operating mode; any excess of this pressure during operation is impermissible.

OTHER REQUIREMENTS

- A driving device must not generate an axial or a radial load of the pump shaft, unless this is exclusively permitted for the pump with a front-end bearing.
- All the matters affecting technical parameters and properties of the pump are given in respective operating manuals, technical specifications and test specifications of the manufacturer.

DIRECTION OF ROTATION

- Determine direction of rotation by looking at the drive shaft. The pump can only be used in the specified direction of rotation.

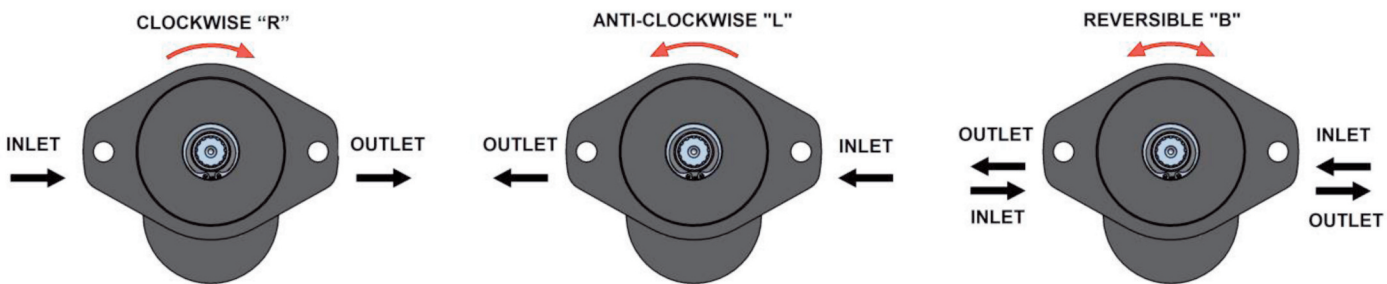

REVERSIBLE DESIGN

- The pumps with the possibility of bidirectional rotation have a different internal arrangement requiring drainage. Two types of drain are used - internal and external. The internal drainage is always interconnected with the outlet by means of valves. The external drainage is solved by an orifice located in the cover opposite the driven gear.

QHDO FLOW RATE AND POWER CURVES

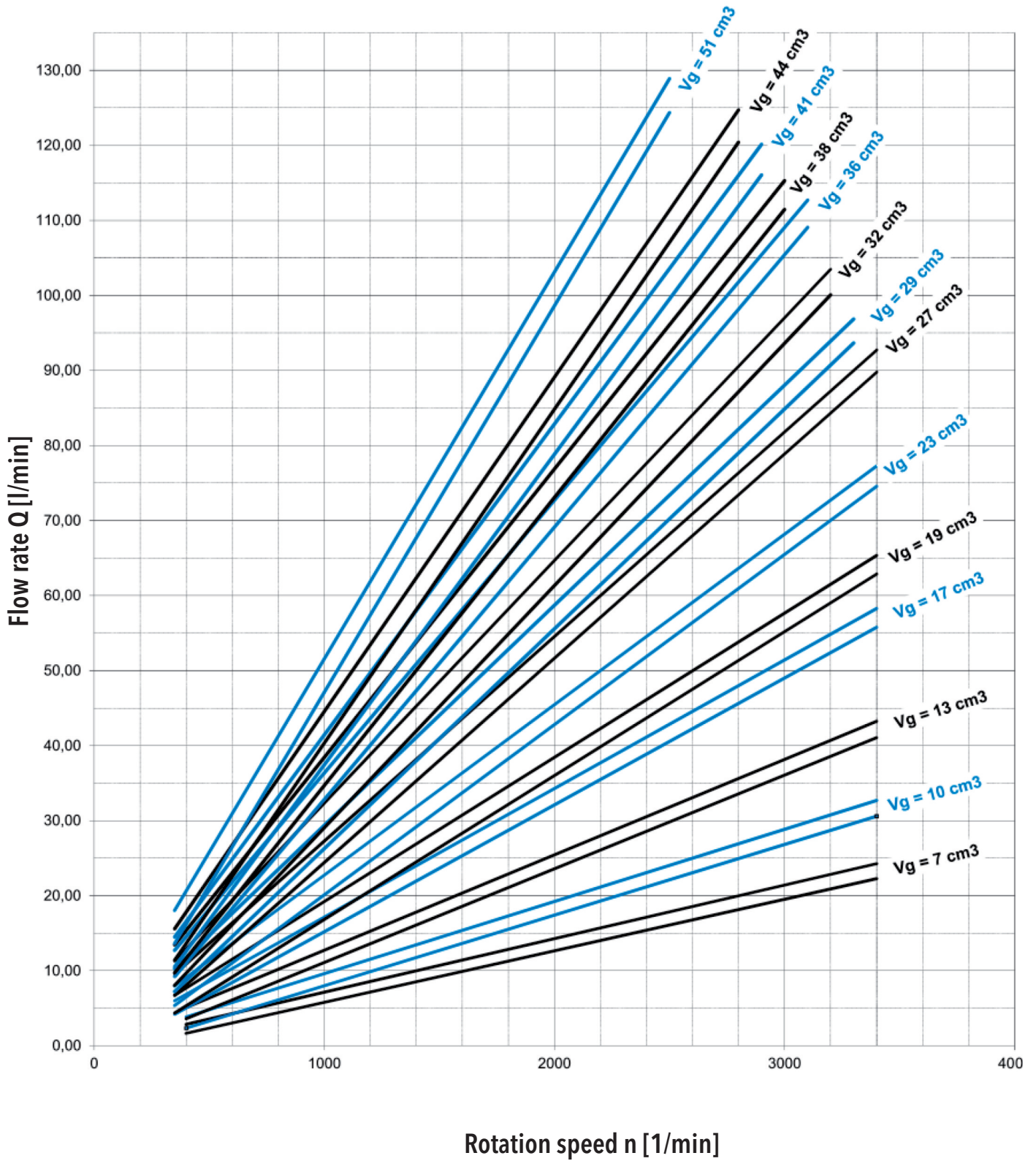

Above curves apply to ISO Vg 46 oil at temperature $t = 45^{\circ}\text{C}$.

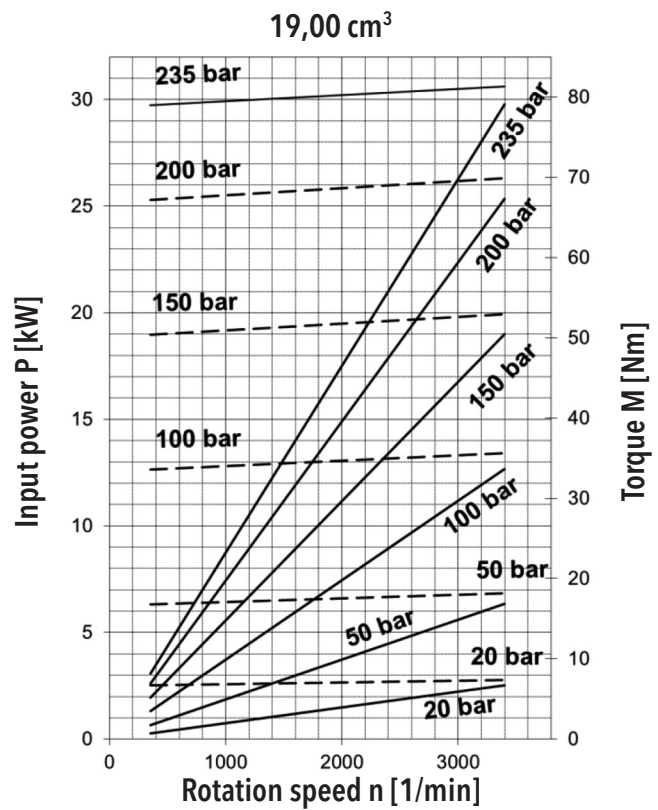
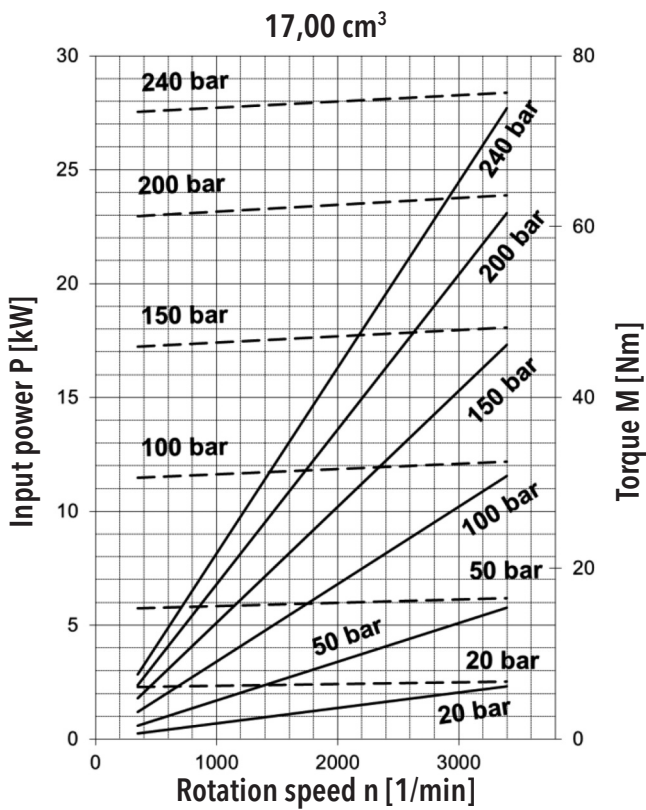
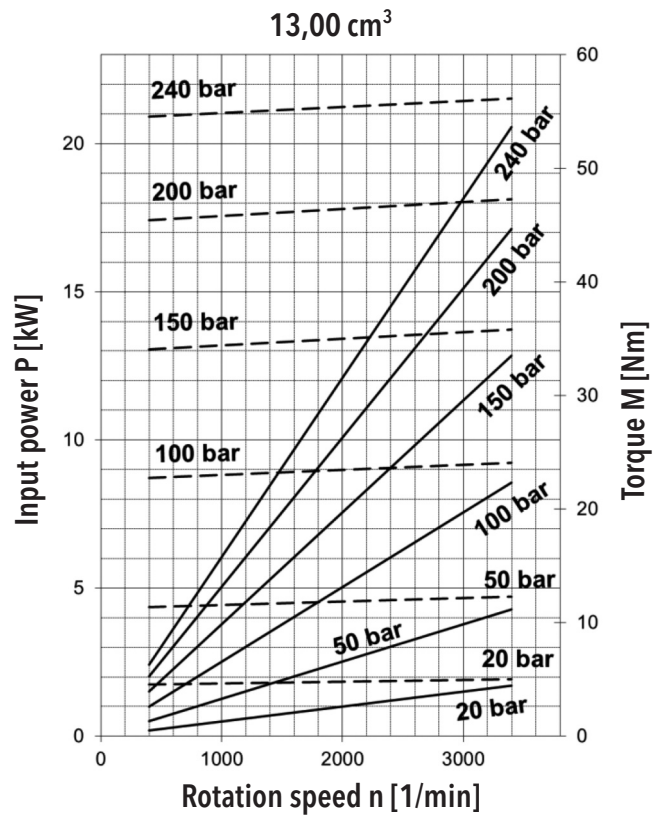
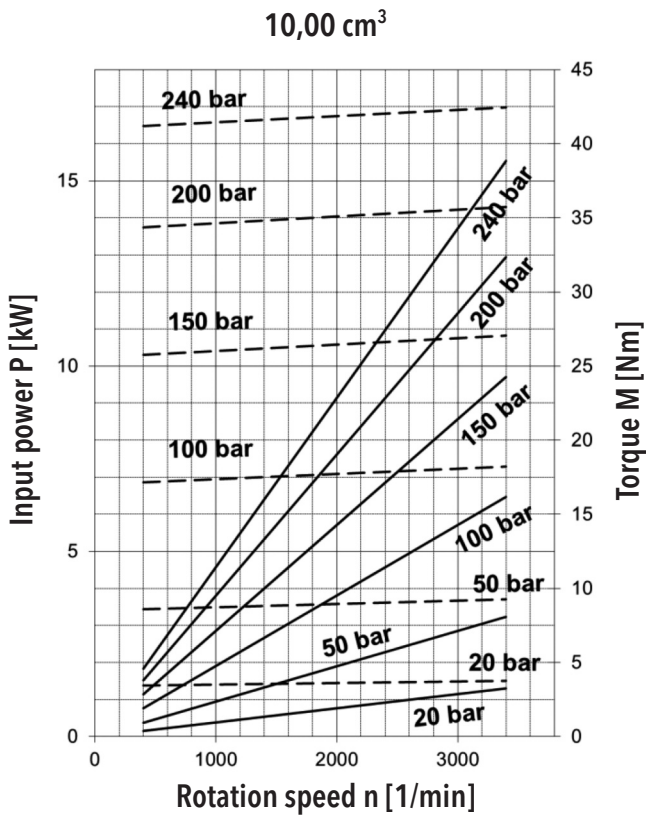

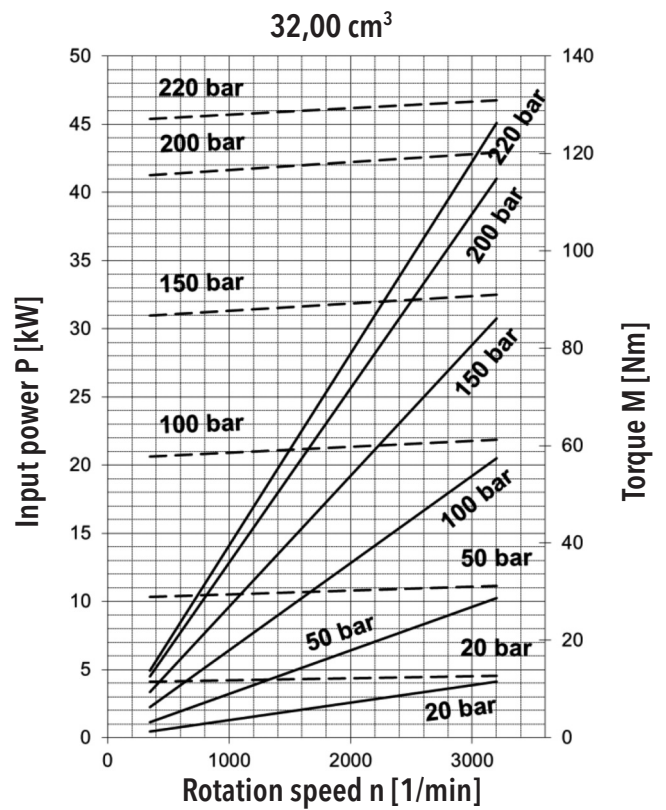
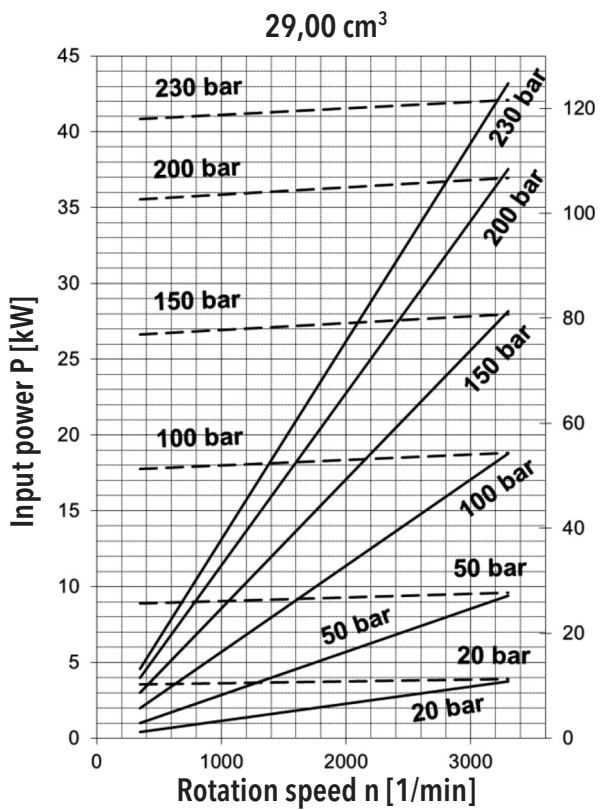
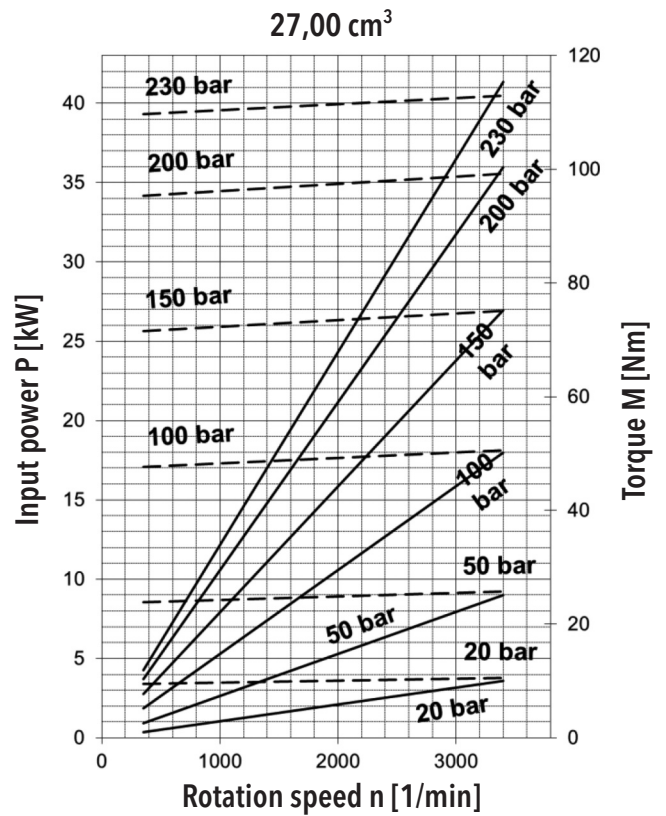
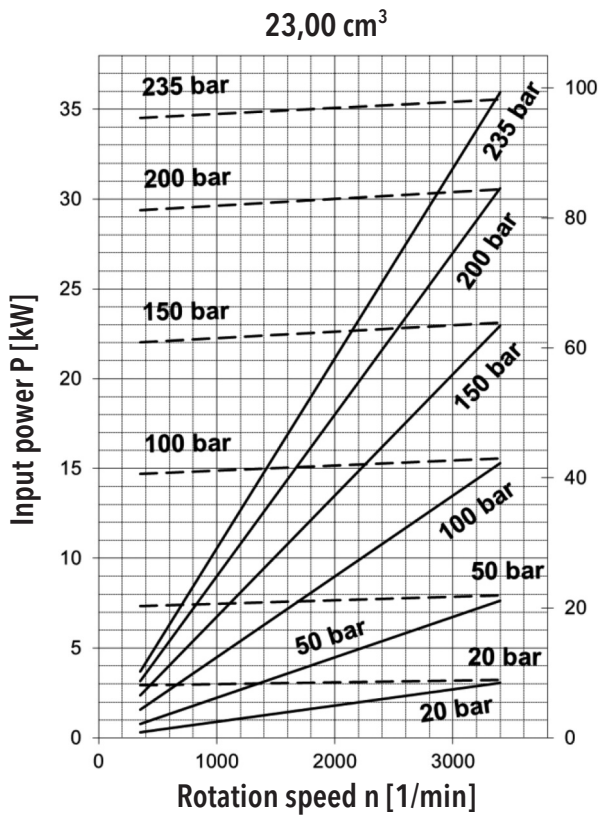

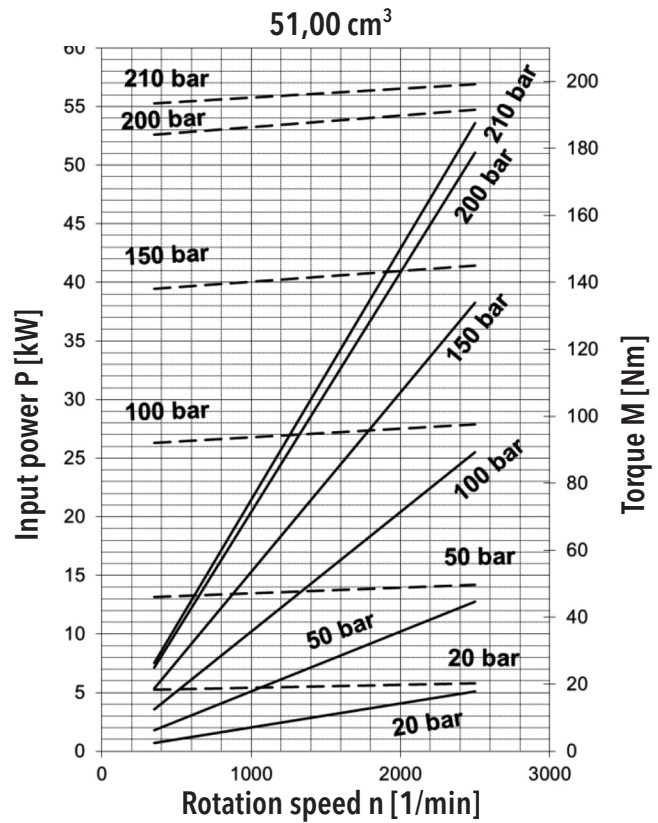
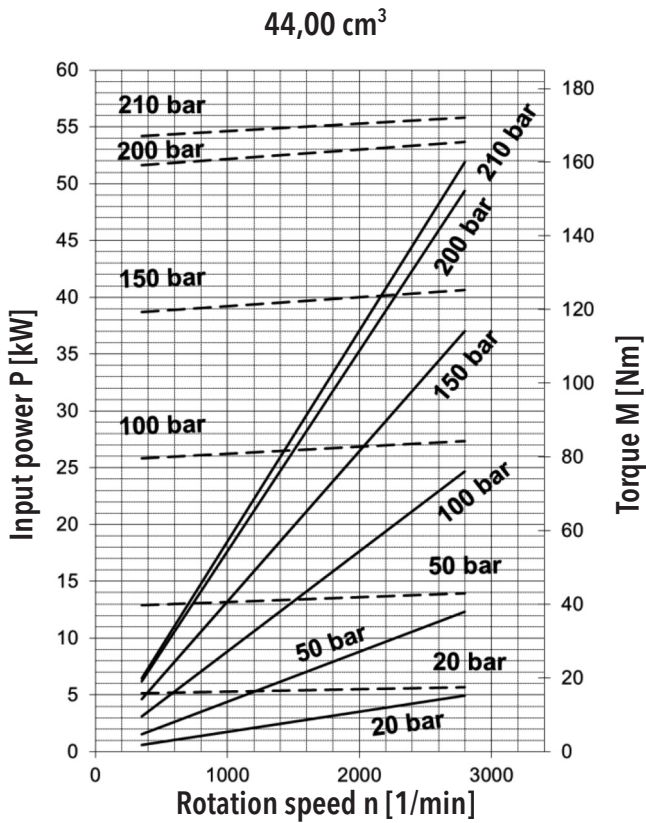
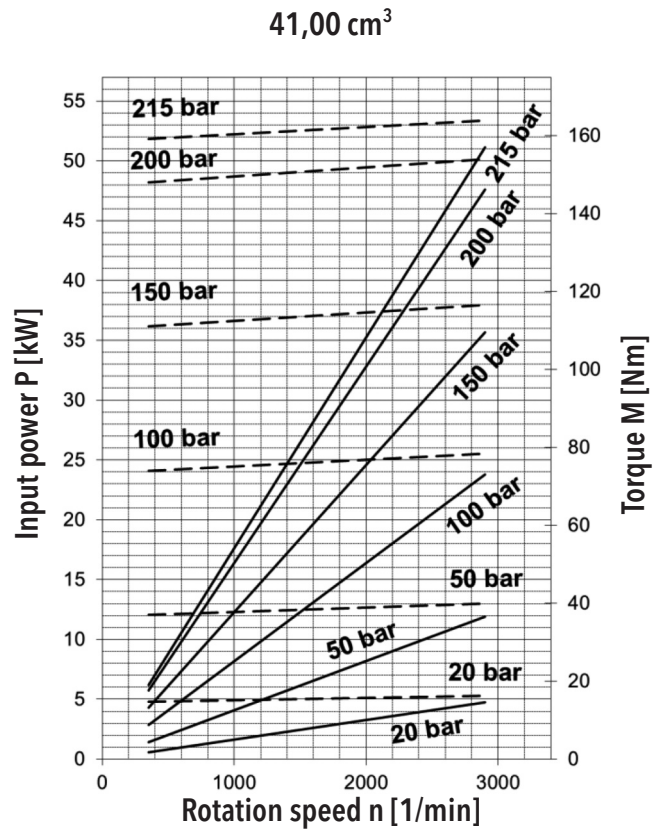
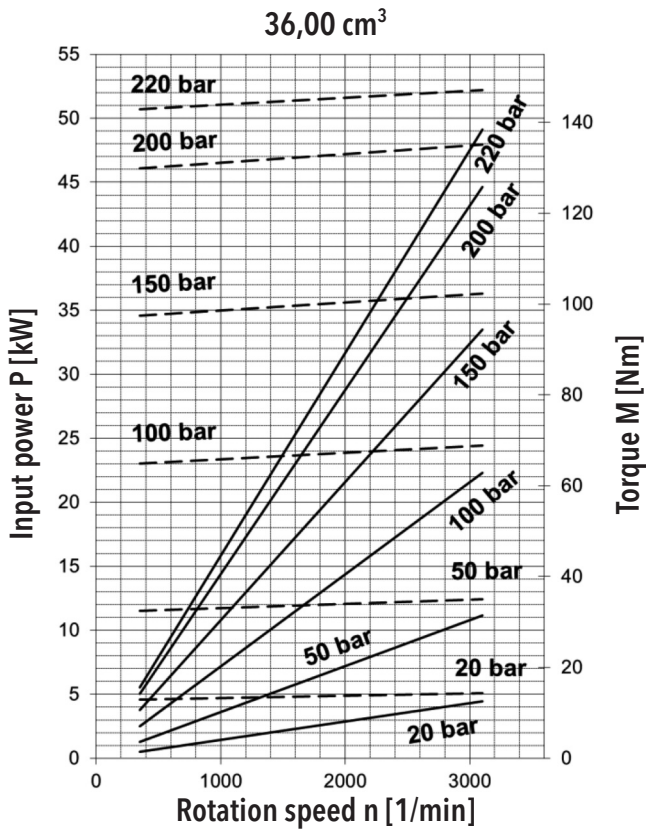





ORDER KEY

QHDO - 23 R - S03 D13 - S U07 U05 - N . 050

Code	Type
QHDO	QHDO Series Gear Pump

Code	Displacement [cm ³]
7	7,21
10	9,71
13	12,85
17	17,31
19	19,41
23	22,95
27	27,54
29	29,64
32	32,66
36	36,72
38	38,82
41	41,84
44	44,99
51	52,07
XX	Other displacements on request





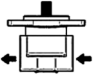
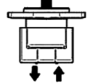
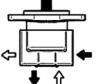



Code	Direction of rotation
R	Clockwise
L	Anti-clockwise
B	Bi-directional















Code	Flange design
R11	 Rectangular flange, centre ring $\varnothing 50,8$ Spacing screw 98,5 x 128
S02	 SAE A - 2 apertures
S03	 SAE B - 2 apertures
B01	 Flange 4 apertures centre ring $\varnothing 90$ spacing 110 x 86
Z	Special desing

Code	Location of inlets and outlets
S	 Side (in the body)
R	 Axial (in the cover)
C	 Combination

Code	Special arrangements
-	No special arrangements
050	With relief valve
004	Without shaft seal

Code	Seal material
N	 NBR
V	FKM (VITON)
H	HNBR

Code	Drive shaft desing
C11	 Cone 1:8
D04	 Spline SAE 9T
D06	 Spline SAE 11T
D13	 Spline SAE B 13T
D15	 Spline SAE BB 15T
D20	 Equilateral spline D-6 x 21e8 x 25e9 x 5
D23	 Spline UNI 221
V17	 Cylindric SAE B, $\varnothing 22,22$ Key 6,4 x 6,4 x 25,4
Z	Special desing

Code	Liquid inlet and outlet connection shape
M07	Thread M 22x1,5
M08	 Thread M 27x1,5
M09	Thread M 27x2
M11	Thread M 33x1,5
M12	Thread M 33x2
G03	Thread BSP G1/2
G04	Thread BSP G3/4
G05	Thread BSP G1"
U03	Thread 3/4-16 UNF
U04	Thread 7/8-14 UNF
U05	Thread 1-1/16-12 UN
U07	Thread 1-5/16-12 UN
H07	 Fitting $\varnothing 13,5; 4xM6/\varnothing 30$
H08	 Fitting $\varnothing 20; 4xM8/\varnothing 40$
H09	 Fitting $\varnothing 18; 4xM8/\varnothing 55$
H10	 Fitting $\varnothing 25; 4xM8/\varnothing 55$
A02	 Fitting SAE (SSS) 3/4
A03	 Fitting SAE (SSS) 1"
A04	 Fitting SAE (SSS) 1 1/4
A05	 Fitting SAE (SSS) 1 1/2
E02	 Fitting SAE (SSM) 3/4
E03	 Fitting SAE (SSM) 1"
E04	 Fitting SAE (SSM) 1 1/4
E05	 Fitting SAE (SSM) 1 1/2
K03	 Fitting $\varnothing 18; 4xM8 / \varnothing 40$
K04	 Fitting $\varnothing 26; 4xM10/\varnothing 51$
K05	Fitting $\varnothing 18; 4xM8 / \varnothing 55$
K06	Fitting $\varnothing 25; 4xM8 / \varnothing 55$
S05	Fitting $\varnothing 22, 4xM10/48x48$
S08	Fitting $\varnothing 19, 4xM10/54x54$
S09	Fitting $\varnothing 27, 4xM10/54x54$
S10	Fitting $\varnothing 16, 4xM8/46x46$
S11	Fitting $\varnothing 23, 4xM8/46x46$
Z	Special desing

An example of designation for the QHDO clockwise pump with displacement of 22.5 cm³, SAE B flange, SAE B spline, UNF side inlets and standard NBR seal without special arrangements: **QHDO-23R-S03D13-SU07U05-N**

Note: In case of combination inlets, with the code „C” is respected following sequence of inlets and outlets:

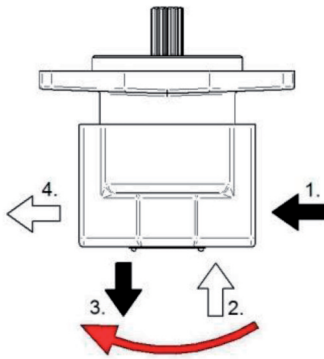

For clockwise and reverse gear pump,
in direction clockwise

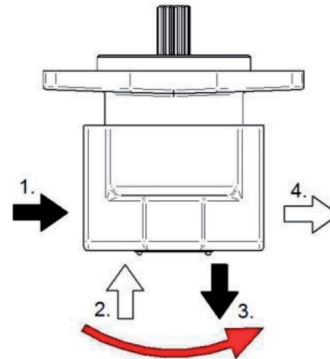

For anti-clockwise gear pump,
in direction anti-clockwise

For. ex....: QHDO-43B-R11C11-CG05 G05 G04 G04 -N
1. 2. 3. 4.

COMBINATIONS OF FLANGES AND SHAFTS

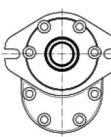
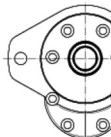
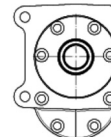
		FLANGE DESIGN			
		R11	S02	S03	B01
DRIVE SHAFT	C11				
	D04	●	●	●	
	D06		●	●	
	D13		●	●	
	D15		●	●	
	D20				●
	D23		●	●	
	V17	●	●	●	

FLANGES DESIGN

R11:

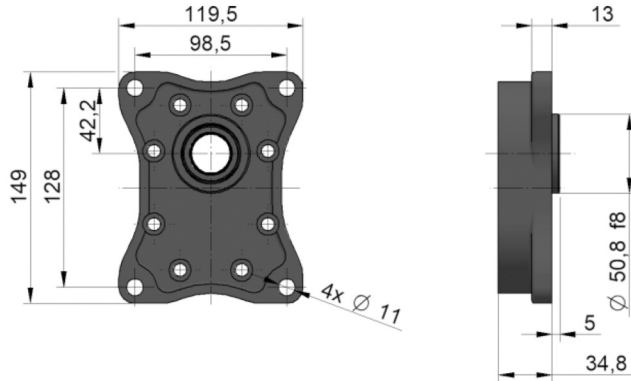

B01:

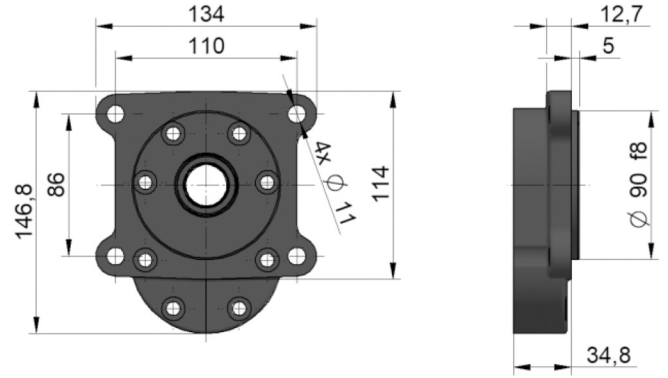

S02:

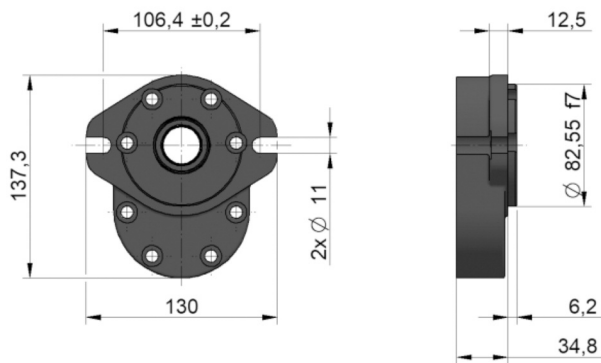

S03:

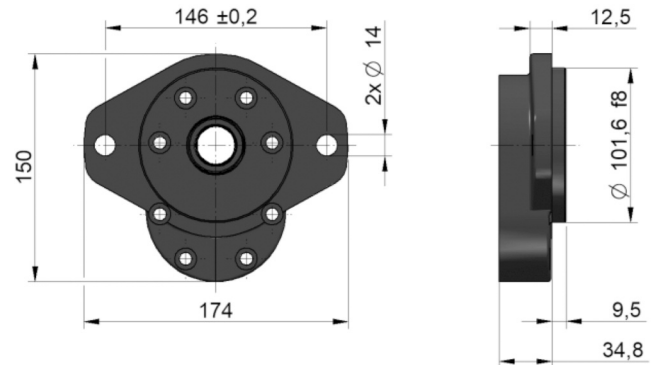

D23:

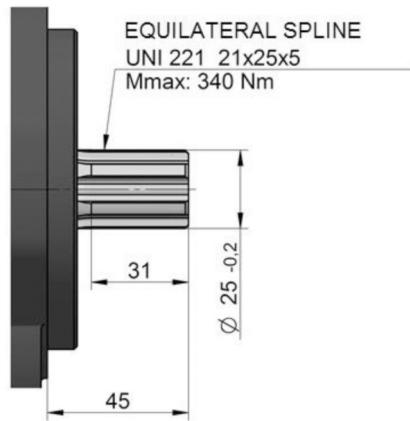

V17:

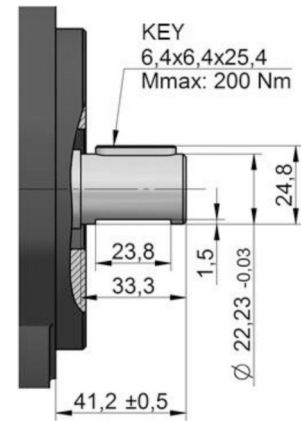

LIQUID INLET AND OUTLET CONNECTION

Metric thread according to ISO 6149

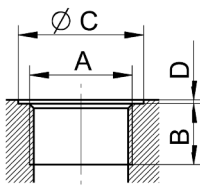

Code	A	B	C	D
M07	M 22 x 1.5	14	28	1
M08	M 27 x 1.5	16	33	1
M09	M 27 x 2.0	16	33	1
M11	M 33 x 1.5	18	40	1
M12	M 33 x 2.0	18	40	1

BSPP pipe thread according to ISO 228-1

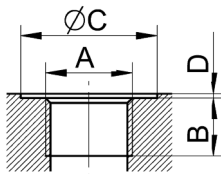

Code	A	B	C	D
G03	G 1/2"	14	33	1
G04	G 3/4"	16	39	1
G05	G 1"	18	45	1

UNF thread according to SAE

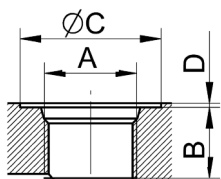

Code	A	B	C	D
U03	3/4 - 16 UNF	15	30	1
U04	7/8 - 14 UNF	17	34	1
U05	1 - 1/16 - 12 UN	19	41	1
U07	1 - 5/16 - 12 UN	19	49	1

Flanged fittings according to DIN 8901/8902

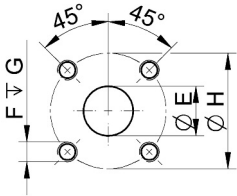

Code	E	F	G	H
H07	13.5	M6	13	30
H08	20.0	M8	16	40
H09	18.0	M8	16	55
H10	25.0	M8	16	55

Flanged fittings according to SAE, metric thread

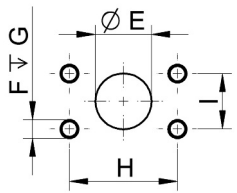

Code	E	F	G	H	I
E02	19.0	M10	22	47.6	22.2
E03	25.4	M10	22	52.4	26.2
E04	30.5	M10	22	58.7	30.2
E05	39.3	M12	27	69.8	35.7

Flanged fittings according to SAE, UNC thread

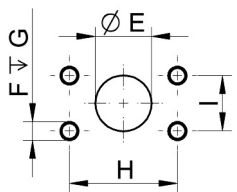

Code	E	F	G	H	I
A02	19.0	3/8-16 UNC-2B	22.0	47.6	22.2
A03	25.4	3/8-16 UNC-2B	22.0	52.4	26.2
A04	30.5	7/16-14 UNC-2B	28.5	58.7	30.2
A05	39.5	1/2-13 UNC-2B	27.0	69.8	35.7

Flanged fittings - „cross“

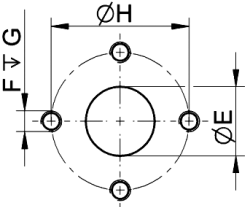

Code	E	F	G	H
K03	18	M8	16	40
K04	26	M10	22	51
K05	18	M8	16	55
K06	25	M8	16	55

Flanged fittings - „square“

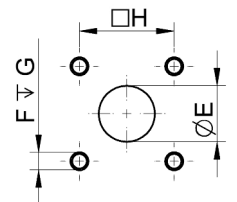

Code	E	F	G	H
S05	22	M10	22	48
S08	19	M10	22	54
S09	27	M10	22	54
S10	16	M8	22	46
S11	23	M8	22	46

CATALOGUE SHETS OF QHDO SERIES BASIC DESIGNS

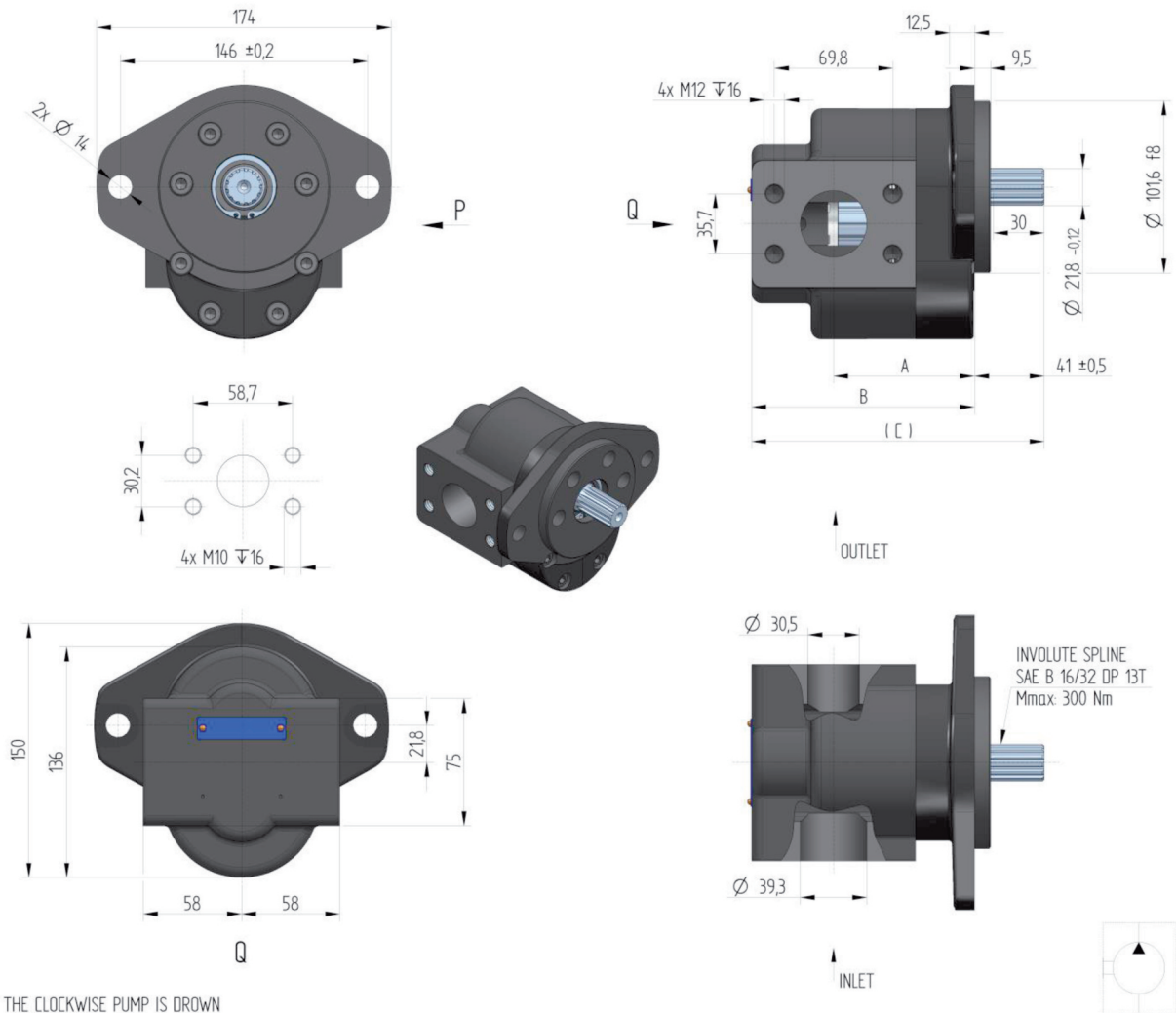

THE CLOCKWISE PUMP IS DRAWN

Order key	purch. code	direct. of rot.	displacement [cm ³ /1]	nom. press. [bar]	speed MIN. [min ⁻¹]	speed MAX. [min ⁻¹]	A [mm]	dimension B [mm]	C [mm]
QHDO-51R-S03D13-SE05E04-N	188 9900	R	51	210	350	2500	83.2	131.5	172.5
QHDO-51L-S03D13-SE05E04-N		L							
QHDO-44R-S03D13-SE05E04-N		R	44	210	350	2800	82.0	129.1	170.1
QHDO-44L-S03D13-SE05E04-N		L							
QHDO-41R-S03D13-SE05E04-N		R	41	215	350	2900	80.8	126.7	167.7
QHDO-41L-S03D13-SE05E04-N		L							
QHDO-38R-S03D13-SE05E04-N		R	38	215	350	3000	79.6	124.4	165.4
QHDO-38L-S03D13-SE05E04-N		L							
QHDO-32R-S03D13-SE05E04-N		R	32	220	350	3200	77.3	119.7	160.7
QHDO-32L-S03D13-SE05E04-N		L							
QHDO-27R-S03D13-SE05E04-N		R	27	230	350	3400	75.3	115.8	156.8
QHDO-27L-S03D13-SE05E04-N		L							
QHDO-23R-S03D13-SE05E04-N		R	23	235	350	3400	73.6	112.3	153.3
QHDO-23L-S03D13-SE05E04-N		L							
QHDO-17R-S03D13-SE05E04-N		R	17	240	350	3400	71.4	108.0	149.0
QHDO-17L-S03D13-SE05E04-N		L							
QHDO-13R-S03D13-SE05E04-N		R	13	240	400	3400	69.7	104.6	145.6
QHDO-13L-S03D13-SE05E04-N		L							
QHDO-10R-S03D13-SE05E04-N		R	10	240	400	3400	68.5	102.2	143.2
QHDO-10L-S03D13-SE05E04-N		L							

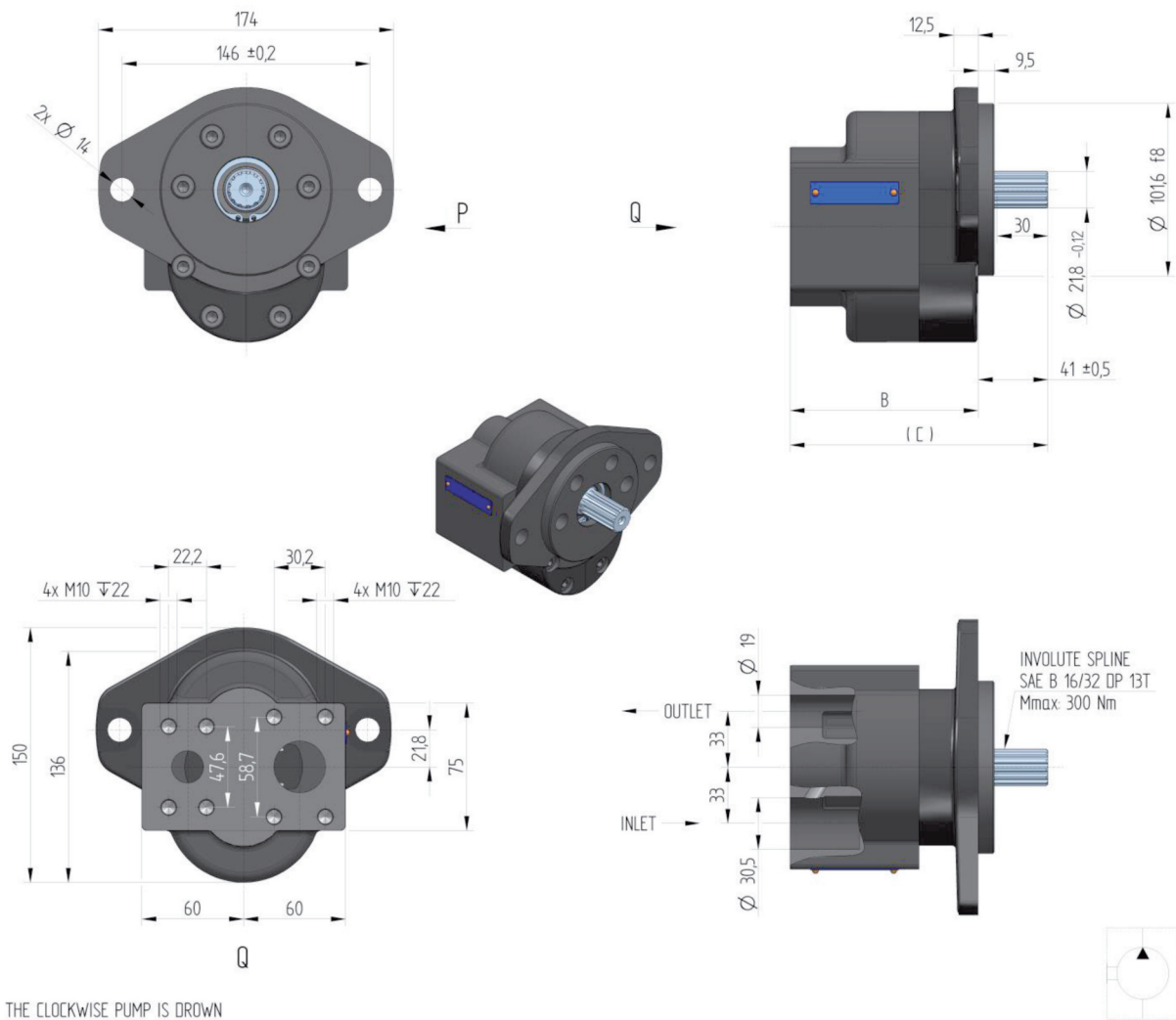

Order key	purch. code	direct. of rot.	displacement [cm ³ /1]	nom. press. [bar]	speed MIN. [min ⁻¹]	speed MAX. [min ⁻¹]	A [mm]	dimension B [mm]	C [mm]
QHDO-51R-S03D13-RE04E02-N		R	51	210	350	2500		129.5	170.5
QHDO-51L-S03D13-RE04E02-N		L							
QHDO-44R-S03D13-RE04E02-N		R	44	210	350	2800		127.1	168.1
QHDO-44L-S03D13-RE04E02-N		L							
QHDO-41R-S03D13-RE04E02-N		R	41	215	350	2900		124.7	165.7
QHDO-41L-S03D13-RE04E02-N		L							
QHDO-38R-S03D13-RE04E02-N		R	38	215	350	3000		122.4	163.4
QHDO-38L-S03D13-RE04E02-N		L							
QHDO-32R-S03D13-RE04E02-N		R	32	220	350	3200		117.7	158.7
QHDO-32L-S03D13-RE04E02-N		L							
QHDO-27R-S03D13-RE04E02-N	188 9907	R	27	230	350	3400		113.8	154.8
QHDO-27L-S03D13-RE04E02-N		L							
QHDO-23R-S03D13-RE04E02-N		R	23	235	350	3400		110.3	151.3
QHDO-23L-S03D13-RE04E02-N		L							
QHDO-17R-S03D13-RE04E02-N		R	17	240	350	3400		106.0	147.0
QHDO-17L-S03D13-RE04E02-N		L							
QHDO-13R-S03D13-RE04E02-N		R	13	240	400	3400		102.6	143.6
QHDO-13L-S03D13-RE04E02-N		L							
QHDO-10R-S03D13-RE04E02-N		R	10	240	400	3400		100.2	141.2
QHDO-10L-S03D13-RE04E02-N		L							

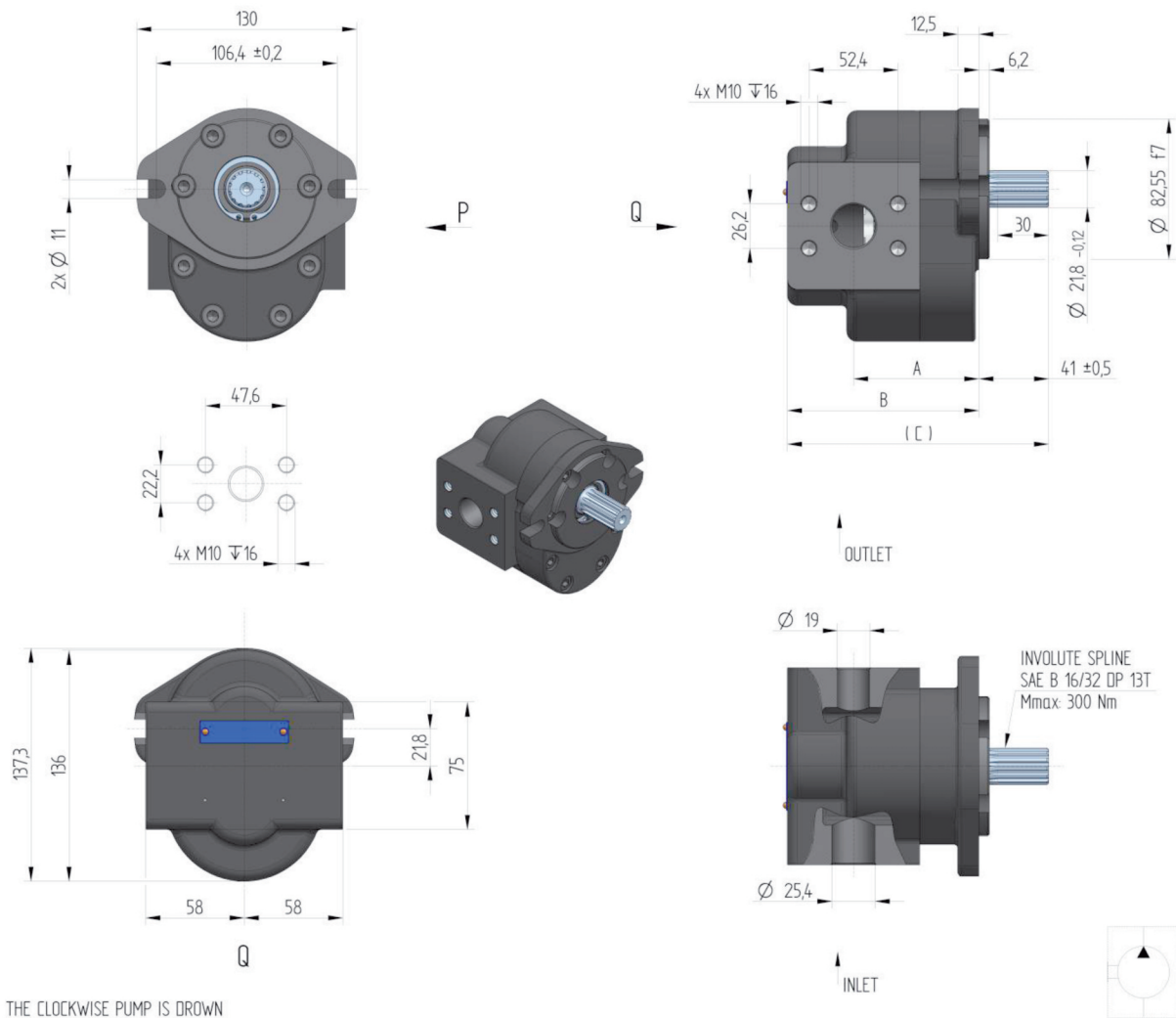

THE CLOCKWISE PUMP IS DROWN

Order key	purch. code	direct. of rot.	displacement [cm ³ /1]	nom. press. [bar]	speed MIN. [min ⁻¹]	speed MAX. [min ⁻¹]	A [mm]	dimension B [mm]	C [mm]
QHDO-51R-S02D13-SE03E02-N		R	51	210	350	2500	83.2	131.5	172.5
QHDO-51L-S02D13-SE03E02-N		L							
QHDO-44R-S02D13-SE03E02-N		R	44	210	350	2800	82.0	129.1	170.1
QHDO-44L-S02D13-SE03E02-N		L							
QHDO-41R-S02D13-SE03E02-N		R	41	215	350	2900	80.8	126.7	167.7
QHDO-41L-S02D13-SE03E02-N		L							
QHDO-38R-S02D13-SE03E02-N		R	38	215	350	3000	79.6	124.4	165.4
QHDO-38L-S02D13-SE03E02-N		L							
QHDO-32R-S02D13-SE03E02-N		R	32	220	350	3200	77.3	119.7	160.7
QHDO-32L-S02D13-SE03E02-N		L							
QHDO-27R-S02D13-SE03E02-N		R	27	230	350	3400	75.3	115.8	156.8
QHDO-27L-S02D13-SE03E02-N		L							
QHDO-23R-S02D13-SE03E02-N		R	23	235	350	3400	73.6	112.3	153.3
QHDO-23L-S02D13-SE03E02-N		L							
QHDO-17R-S02D13-SE03E02-N		R	17	240	350	3400	71.4	108.0	149.0
QHDO-17L-S02D13-SE03E02-N		L							
QHDO-13R-S02D13-SE03E02-N		R	13	240	400	3400	69.7	104.6	145.6
QHDO-13L-S02D13-SE03E02-N		L							
QHDO-10R-S02D13-SE03E02-N		R	10	240	400	3400	68.5	102.2	143.2
QHDO-10L-S02D13-SE03E02-N		L							

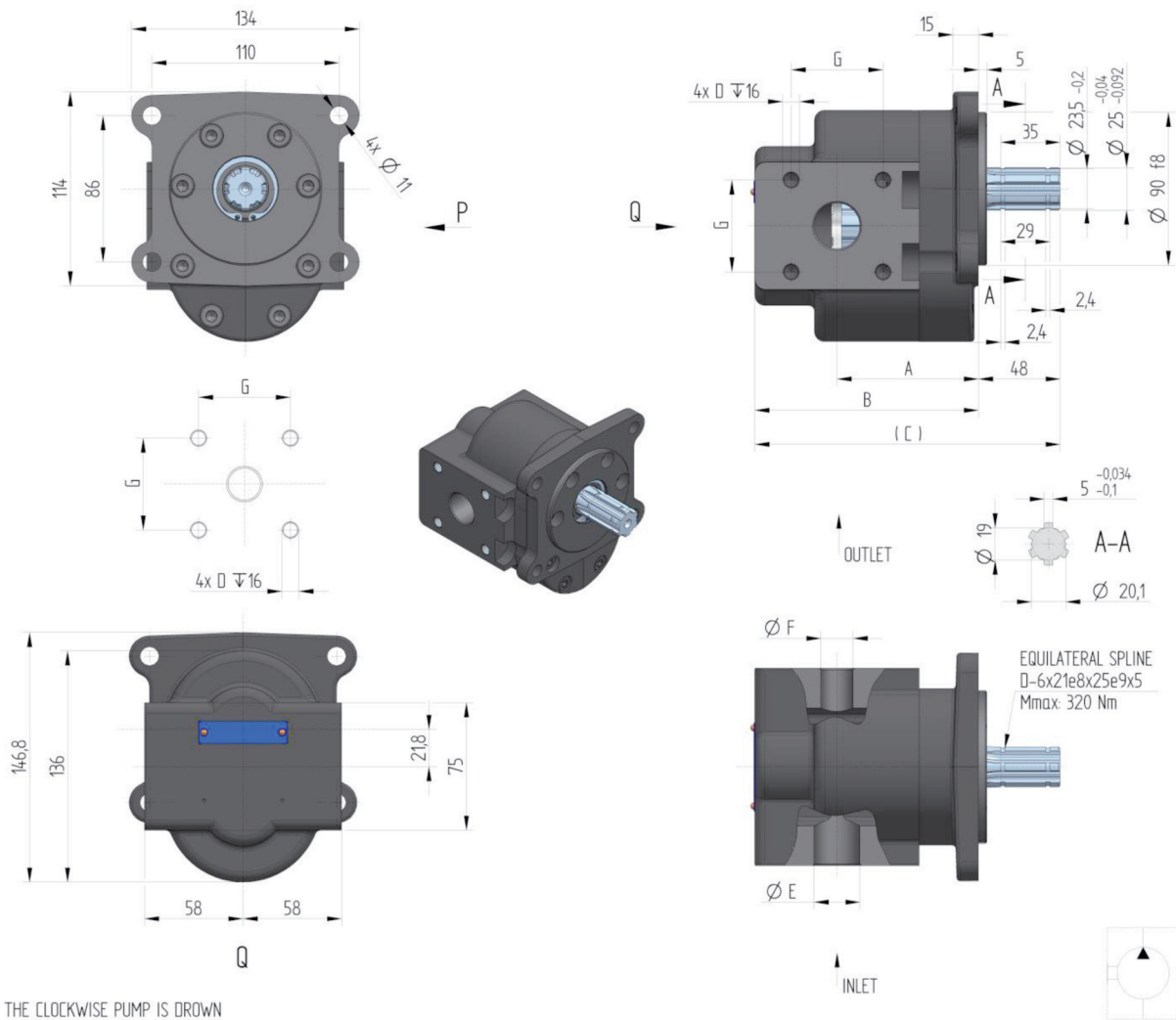

THE CLOCKWISE PUMP IS DROWN

Order key	purch. code	direct. of rot.	displacement [cm ³ /1]	nom. press. [bar]	speed MIN. [min ⁻¹]	speed MAX. [min ⁻¹]	dimension						
							A [mm]	B [mm]	C [mm]	D [mm]	E [mm]	F [mm]	G [mm]
QHDO-51R-B01D20-SS09S08-N	188 9905	R	51	210	350	2500	83.2	131.5	172.5	M10	27	19	54
QHDO-51L-B01D20-SS09S08-N	188 9902	L											
QHDO-44R-B01D20-SS09S08-N		R	44	210	350	2800	82.0	129.1	170.1	M10	27	19	54
QHDO-44L-B01D20-SS09S08-N		L											
QHDO-41R-B01D20-SS09S08-N		R	41	215	350	2900	80.8	126.7	167.7	M10	27	19	54
QHDO-41L-B01D20-SS09S08-N		L											
QHDO-38R-B01D20-SS09S08-N		R	38	215	350	3000	79.6	124.4	165.4	M10	27	19	54
QHDO-38L-B01D20-SS09S08-N		L											
QHDO-32R-B01D20-SS11S10-N	188 9903	R	32	220	350	3200	77.3	119.7	160.7	M8	23	16	46
QHDO-32L-B01D20-SS11S10-N	188 9904	L											
QHDO-27R-B01D20-SS11S10-N		R	27	230	350	3400	75.3	115.8	156.8	M8	23	16	46
QHDO-27L-B01D20-SS11S10-N		L											
QHDO-23R-B01D20-SS11S10-N		R	23	235	350	3400	73.6	112.3	153.3	M8	23	16	46
QHDO-23L-B01D20-SS11S10-N		L											
QHDO-17R-B01D20-SS11S10-N		R	17	240	350	3400	71.4	108.0	149.0	M8	23	16	46
QHDO-17L-B01D20-SS11S10-N		L											
QHDO-13R-B01D20-SS11S10-N		R	13	240	400	3400	69.7	104.6	145.6	M8	23	16	46
QHDO-13L-B01D20-SS11S10-N		L											
QHDO-10R-B01D20-SS11S10-N		R	10	240	400	3400	68.5	102.2	143.2	M8	23	16	46
QHDO-10L-B01D20-SS11S10-N		L											

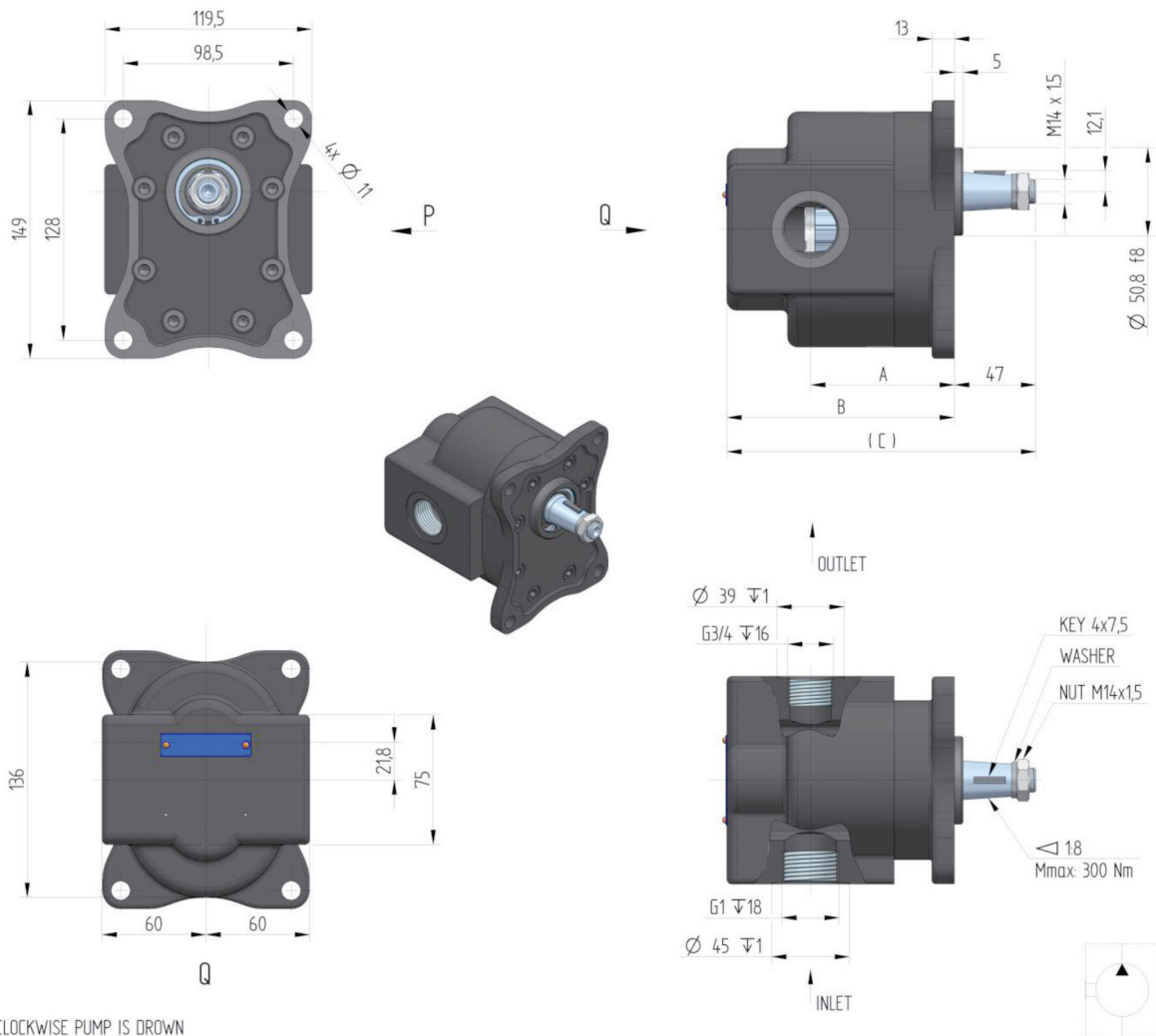

THE CLOCKWISE PUMP IS DROWN

Order key	purch. code	direct. of rot.	displacement [cm ³ /1]	nom. press. [bar]	speed MIN. [min ⁻¹]	speed MAX. [min ⁻¹]	A [mm]	dimension B [mm]	C [mm]
QHDO-51R-R11C11-SG05G04-N		R	51	210	350	2500	83.2	131.5	172.5
QHDO-51L-R11C11-SG05G04-N		L	51	210	350	2500	83.2	131.5	172.5
QHDO-44R-R11C11-SG05G04-N		R	44	210	350	2800	82.0	129.1	170.1
QHDO-44L-R11C11-SG05G04-N		L	44	210	350	2800	82.0	129.1	170.1
QHDO-41R-R11C11-SG05G04-N		R	41	215	350	2900	80.8	126.7	167.7
QHDO-41L-R11C11-SG05G04-N		L	41	215	350	2900	80.8	126.7	167.7
QHDO-38R-R11C11-SG05G04-N		R	38	215	350	3000	79.6	124.4	165.4
QHDO-38L-R11C11-SG05G04-N		L	38	215	350	3000	79.6	124.4	165.4
QHDO-32R-R11C11-SG05G04-N		R	32	220	350	3200	77.3	119.7	160.7
QHDO-32L-R11C11-SG05G04-N		L	32	220	350	3200	77.3	119.7	160.7
QHDO-27R-R11C11-SG05G04-N		R	27	230	350	3400	75.3	115.8	156.8
QHDO-27L-R11C11-SG05G04-N		L	27	230	350	3400	75.3	115.8	156.8
QHDO-23R-R11C11-SG05G04-N		R	23	235	350	3400	73.6	112.3	153.3
QHDO-23L-R11C11-SG05G04-N		L	23	235	350	3400	73.6	112.3	153.3
QHDO-17R-R11C11-SG05G04-N		R	17	240	350	3400	71.4	108.0	149.0
QHDO-17L-R11C11-SG05G04-N		L	17	240	350	3400	71.4	108.0	149.0
QHDO-13R-R11C11-SG05G04-N		R	13	240	400	3400	69.7	104.6	145.6
QHDO-13L-R11C11-SG05G04-N		L	13	240	400	3400	69.7	104.6	145.6
QHDO-10R-R11C11-SG05G04-N		R	10	240	400	3400	68.5	102.2	143.2
QHDO-10L-R11C11-SG05G04-N		L	10	240	400	3400	68.5	102.2	143.2

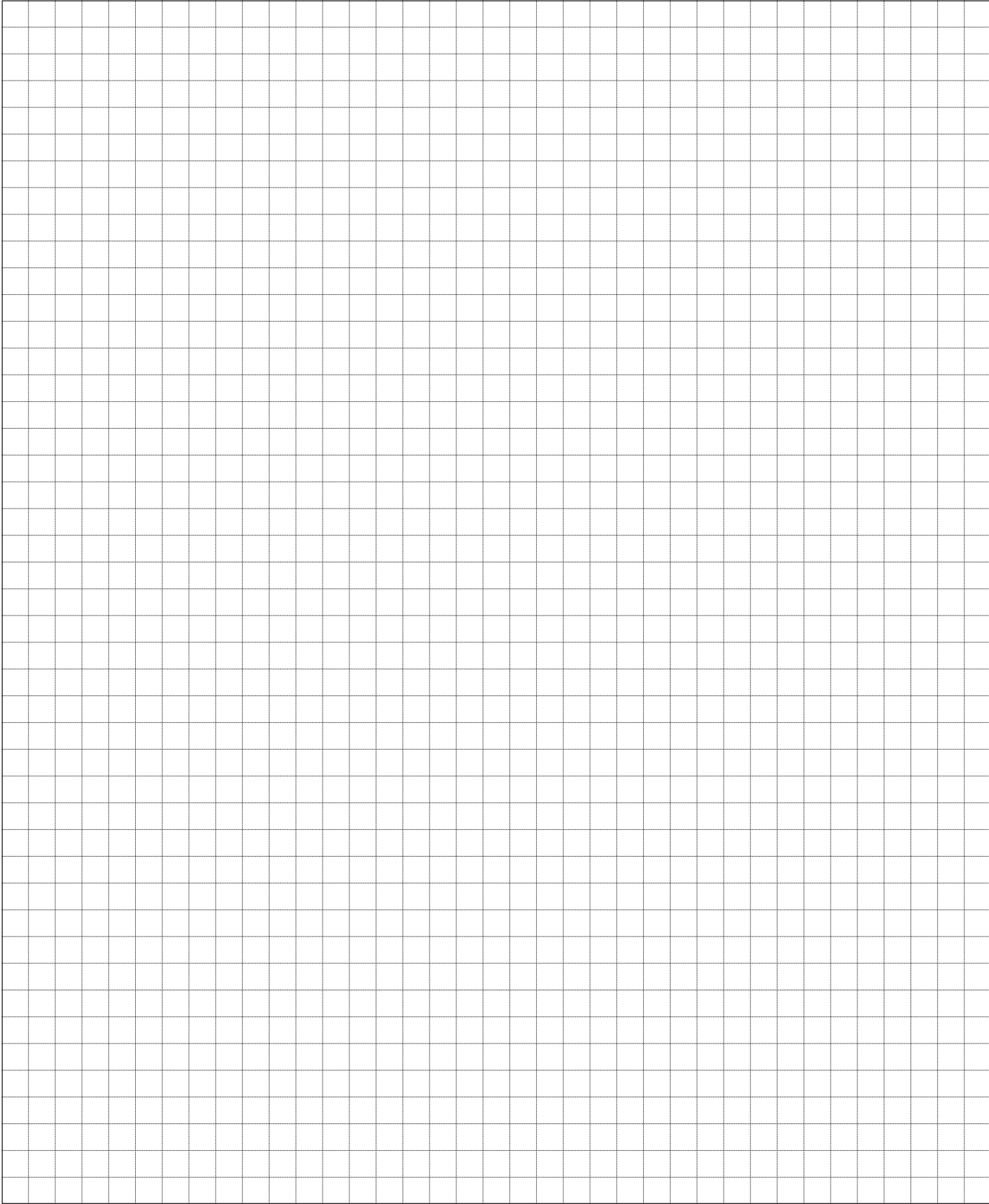

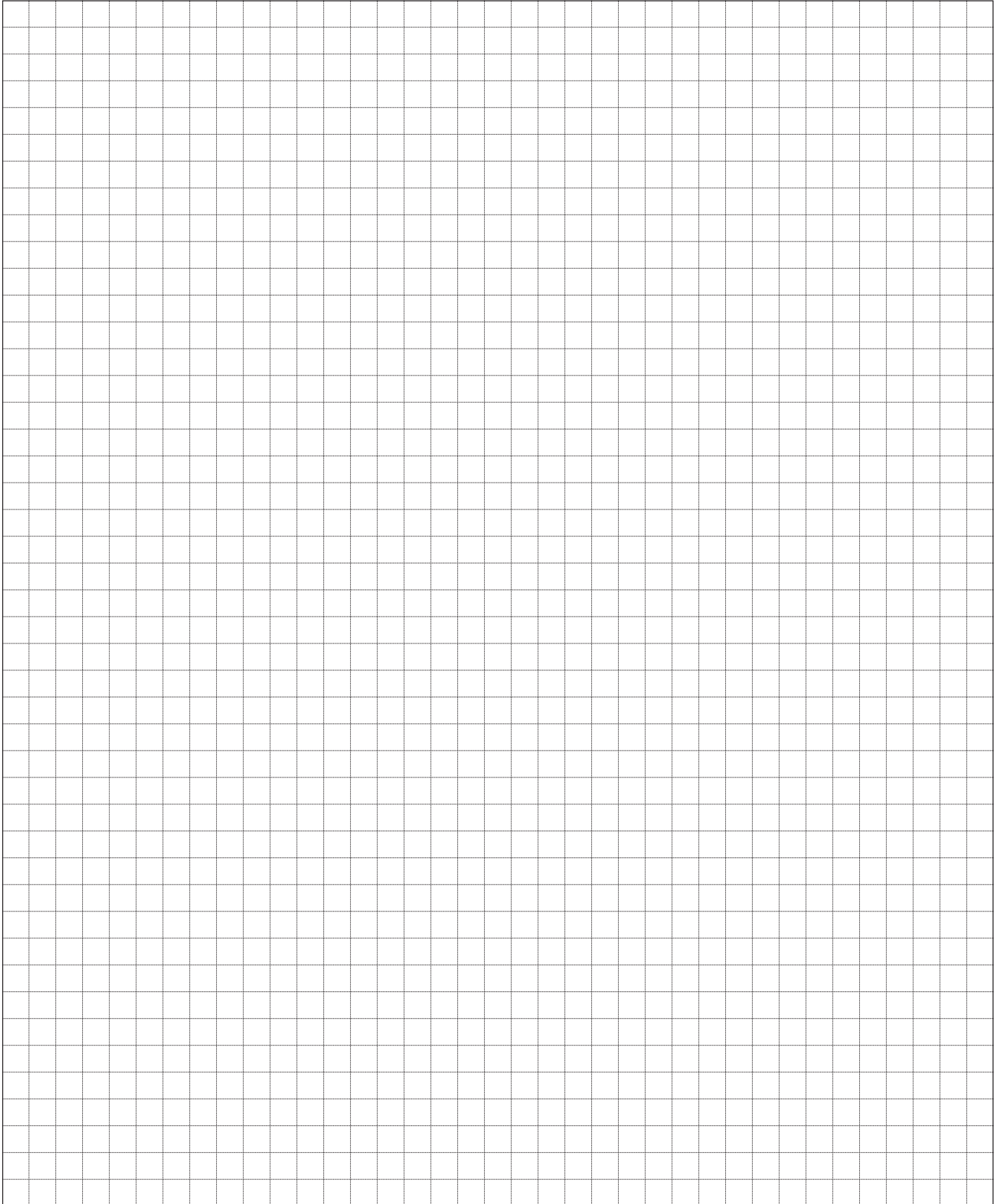

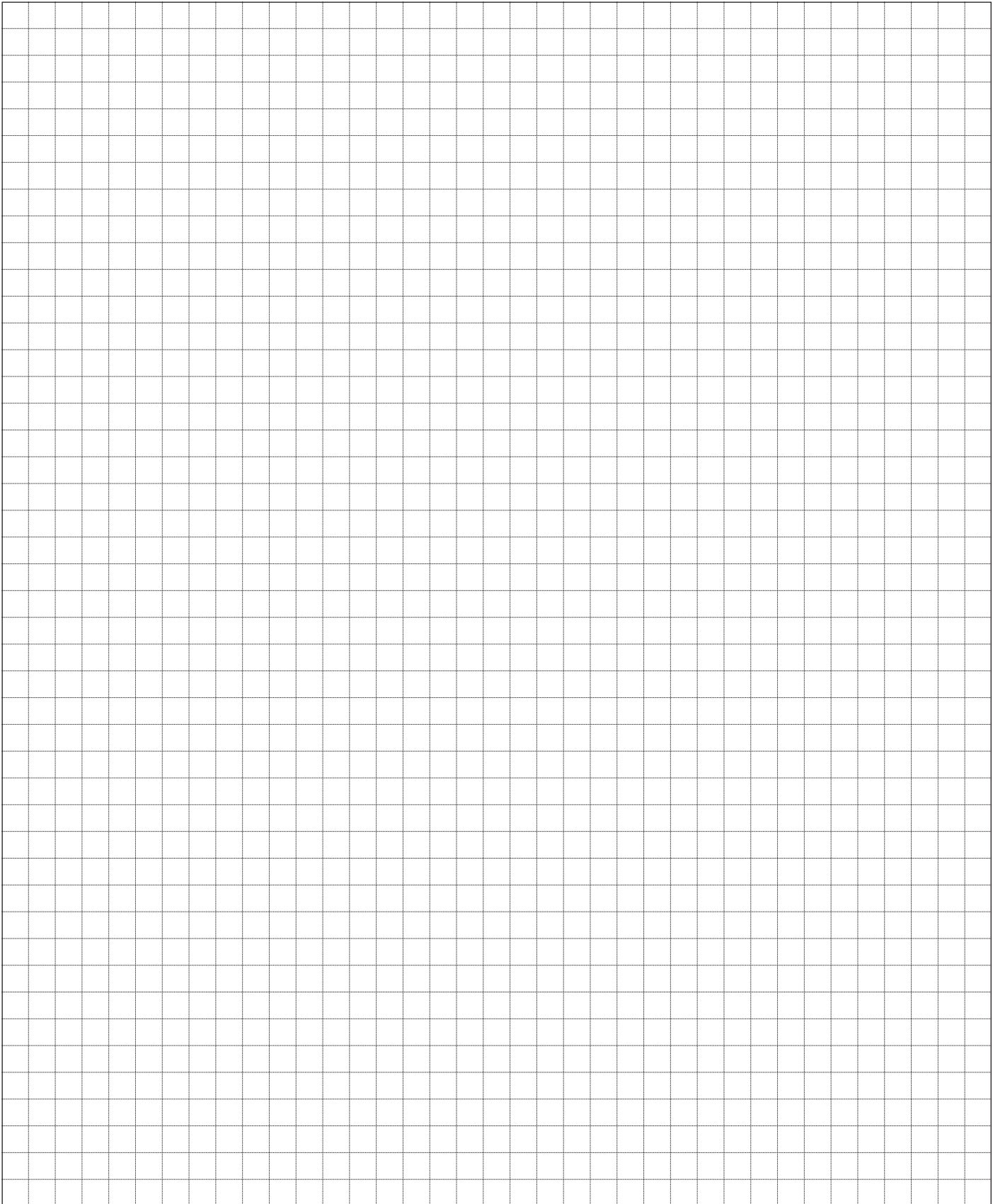

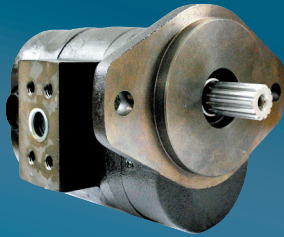

jihostroj
AERO TECHNOLOGY & HYDRAULICS

JIHOSTROJ a.s.
Budějovická 148
CZ 382 32 Velešín
Czech Republic
tel.: +420 380 340 511
fax: +420 380 340 612
e-mail: mailbox@jihostroj.cz
http: //www.jihostroj.com

GPS 48°49'51.748" N 14°27'40.770" E

