

Displacement from 0.8 to 11.8 ccm
Pressure up to 280 bar
Speed from 500 to 5000 RPM

GEAR PUMPS
P23

TABLE OF CONTENTS

DESCRIPTION.....	2
BASIC PARTS.....	2
PARAMETER TABLE.....	3
FORMULAS USED FOR CALCULATION.....	4
PUMP EFFICIENCIES.....	4
WORKING LIQUID.....	5
PRESSURE LOAD.....	5
DIRECTION OF ROTATION.....	6
REVERSIBLE DESIGN.....	6
P23 FLOW RATE AND POWER CURVES.....	7
ORDER KEY - SINGLE VERSION.....	11
ORDER KEY - MULTIPLE VERSION.....	12
COMBINATION OF FLANGES AND SHAFTS.....	13
FLANGE DESIGN.....	14
DRIVE SHAFTS.....	15
COMBINATION OF LIQUID INLETS AND OUTLETS.....	17
CATALOGUE SHEETS OF P23 SERIES BASIC DESIGN.....	18
NOTES.....	34

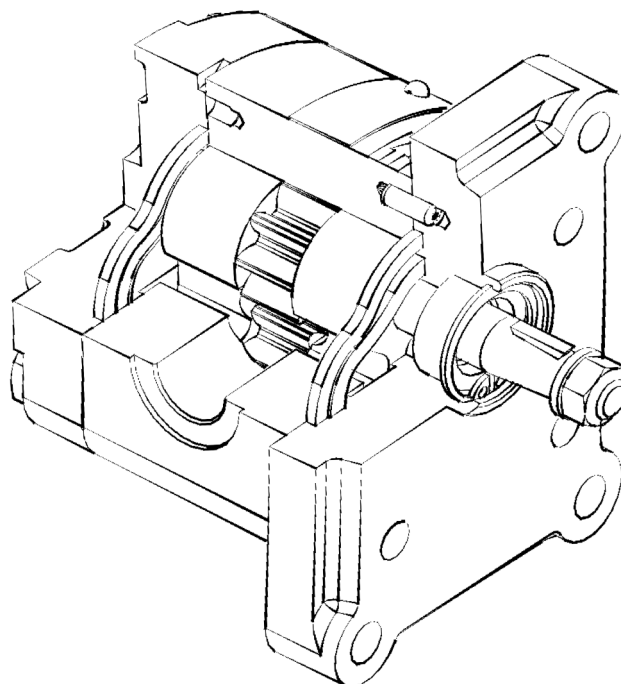

DESCRIPTION

- P23 line pumps are designed for advanced hydraulic systems with lower capacity (approximately up to 10 kW) with high operational reliability and long service life. They have been produced in both one-way and reversible version with internal or external drainage. A wide variety of designs with diverse drives, connecting flanges, fluid inlets and outlets enable the pumps to be used in hydraulic systems of both fixed and mobile machines and equipment. They are available in a special version modified for small hydraulic aggregates, too. Types of connections and flanges as well as the other connecting dimensions correspond to all worldwide standards.
- P23 line pumps are also available as multiple versions (2 sections, 3 sections, etc.) with separate inlets of working fluid into individual sections or with one common inlet. Individual sections can be sealed from each other.
- The pumps are made of high-quality aluminum alloys with steel gear-wheels and they are equipped with hydraulic axial play compensation of new generation. Compared with the previous versions P and P2, the pressure and noise parameters as well as the efficiency in the entire range of speed have been improved. As for their dimensions, P23 pumps are fully interchangeable with P and P2 pumps.

BASIC PARTS

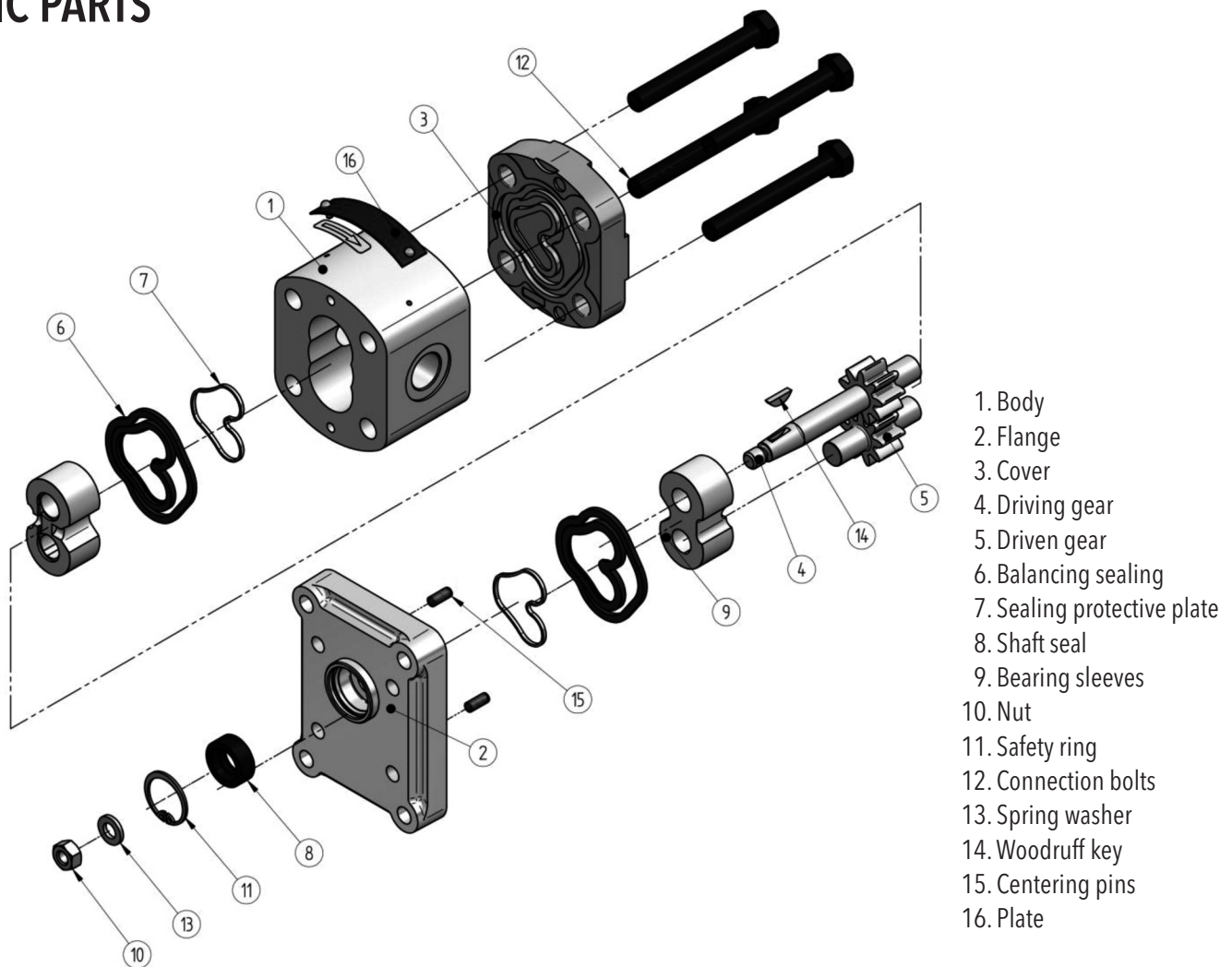

* Inlet pressure in the reversible design can be up to $p_1 = p_{2n}$ -70 bar max. External drainage must be used in case of the reversible design.
** Outlet pressure in the reversible design is 10% lower than shown in the table (depending on operating conditions - it is necessary to consult with the manufacturer).

Nominal Size Parameters		Sym.	Unit	P23 0.80	P23 1.20	P23 1.60	P23 2.10	P23 2.50	P23 3.30	P23 3.60
Actual displacement		V_g	[cm ³]	0.855	1.257	1.686	2.086	2.514	3.316	3.611
Rotation speed	nominal	n_n	[min ⁻¹]	1500	1500	1500	1500	1500	1500	1500
	minimum	n_{min}	[min ⁻¹]	800	800	600	600	500	500	500
	maximum	n_{max}	[min ⁻¹]	5000	5000	4500	4500	4000	4000	4000
Pressure at inlet*	minimum	p_{1min}	[bar]	-0.3	-0.3	-0.3	-0.3	-0.3	-0.3	-0.3
	maximum	p_{1max}	[bar]	0.5	0.5	0.5	0.5	0.5	0.5	0.5
Pressure at outlet**	max. continuous	p_{2n}	[bar]	280	280	280	280	280	280	260
	maximum	p_{2max}	[bar]	300	300	300	300	300	300	280
	peak	p_3	[bar]	310	310	310	310	310	310	290
Nominal flow rate (min.) at n_n and p_{2n}		Q_n	[dm ³ .min ⁻¹]	1.07	1.60	2.13	2.71	3.35	4.54	4.98
Maximum flow rate at n_{max} a p_{2max}		Q_{max}	[dm ³ .min ⁻¹]	3.92	5.88	7.06	9.26	9.80	12.94	14.11
Nominal input power (max.) at n_n and p_{2n}		P_n	[kW]	0.70	1.04	1.39	1.72	2.07	2.97	3.35
Maximum input power at n_{max} a p_{2max}		P_{max}	[kW]	2.51	3.70	4.96	5.52	6.65	7.80	7.93
Weight		m	[kg]	0.82	0.84	0.85	0.87	0.89	0.92	0.93

Nominal Size Parameters		Sym.	Unit	P23 4.40	P23 4.80	P23 5.80	P23 6.20	P23 7.90	P23 11.80
Actual displacement		V_g	[cm ³]	4.386	4.787	5.804	6.205	7.890	11.795
Rotation speed	nominal	n_n	[min ⁻¹]	1500	1500	1500	1500	1500	1500
	minimum	n_{min}	[min ⁻¹]	500	500	500	500	500	500
	maximum	n_{max}	[min ⁻¹]	4000	3800	3800	3500	3000	1800
Pressure at inlet*	minimum	p_{1min}	[bar]	-0.3	-0.3	-0.3	-0.3	-0.3	-0.3
	maximum	p_{1max}	[bar]	0.5	0.5	0.5	0.5	0.5	0.5
Pressure at outlet**	max. continuous	p_{2n}	[bar]	250	230	200	180	160	100
	maximum	p_{2max}	[bar]	270	250	220	200	180	150
	peak	p_3	[bar]	280	260	230	210	190	160
Nominal flow rate (min.) at n_n and p_{2n}		Q_n	[dm ³ .min ⁻¹]	6.06	6.61	8.00	8.56	10.90	16.30
Maximum flow rate at n_{max} a p_{2max}		Q_{max}	[dm ³ .min ⁻¹]	17.25	17.88	21.60	21.27	23.23	20.82
Nominal input power (max.) at n_n and p_{2n}		P_n	[kW]	3.23	3.24	3.41	3.29	3.71	3.47
Maximum input power at n_{max} a p_{2max}		P_{max}	[kW]	9.29	8.29	9.51	8.52	8.35	2.64
Weight		m	[kg]	0.96	0.98	1.02	1.04	1.10	1.25

Nominal Size Parameters		Sym.	Unit	P23 1.00	P23 2.30	P23 2.65	P23 6.40	P23 7.00	P23 10.00
Actual displacement		V_g	[cm ³]	1.016	2.301	2.674	6.419	7.007	10.003
Rotation speed	nominal	n_n	[min ⁻¹]	1500	1500	1500	1500	1500	1500
	minimum	n_{min}	[min ⁻¹]	800	500	500	500	500	500
	maximum	n_{max}	[min ⁻¹]	5000	4500	4500	3500	3000	1800
Pressure at inlet*	minimum	p_{1min}	[bar]	-0.3	-0.3	-0.3	-0.3	-0.3	-0.3
	maximum	p_{1max}	[bar]	0.5	0.5	0.5	0.5	0.5	0.5
Pressure at outlet**	max. continuous	p_{2n}	[bar]	280	280	280	180	170	100
	maximum	p_{2max}	[bar]	300	300	300	200	190	150
	peak	p_3	[bar]	310	310	310	210	200	160
Nominal flow rate (min.) at n_n and p_{2n}		Q_n	[dm ³ .min ⁻¹]	1.28	3.12	3.62	8.85	9.65	13.90
Maximum flow rate at n_{max} a p_{2max}		Q_{max}	[dm ³ .min ⁻¹]	4.90	10.14	11.69	21.95	20.58	17.64
Nominal input power (max.) at n_n and p_{2n}		P_n	[kW]	0.84	1.89	2.20	3.40	3.50	2.94
Maximum input power at n_{max} a p_{2max}		P_{max}	[kW]	2.99	6.09	7.08	8.81	7.83	5.30
Weight		m	[kg]	0.83	0.88	0.90	1.05	1.08	1.20

FORMULAS USED FOR CALCULATION

Flow rate
Q

$$Q = \frac{V_g \cdot n}{1000} \cdot \eta_v \quad [\text{dm}^3 \cdot \text{min}^{-1}]$$

V_g [cm³] pump displacement
 n [min⁻¹] rotation speed
 η_v [-] volumetric efficiency

Displacement
V_g

$$V_g = \frac{Q \cdot 1000}{n \cdot \eta_v} \quad [\text{cm}^3]$$

Torque
M_k

$$M_k = \frac{V_g \cdot p}{20 \cdot \pi \cdot \eta_m} \quad [\text{Nm}]$$

p [bar] required pressure at outlet
 η_m [-] mechanical efficiency

Input power
P

$$P = \frac{V_g \cdot n \cdot p}{600 \cdot 1000 \cdot \eta_t} \quad [\text{kW}]$$

η_t [-] total efficiency

PUMP EFFICIENCIES

Volumetric efficiency

η_v

It determines the amount of flow losses. Its value is $\eta_v = 0,92 \div 0,98$ (depending on rotation speed, viscosity of working liquid and outlet pressure). It can be expressed as follows:

$$\eta_v = \frac{Q_{act.}}{Q_{theor}} \quad [-]$$

$Q_{act.}$ [dm³ · min⁻¹] actual flow rate
 Q_{theor} [dm³ · min⁻¹] theoretical flow rate

Mechanical efficiency

η_m

It determines mechanical losses. Its value is about $\eta_m = 0,85$. It can be expressed as follows:

$$\eta_m = \frac{M_{theor}}{M_{act.}} \quad [-]$$

$M_{act.}$ [Nm] actual torque
 M_{theor} [Nm] theoretical torque

Total efficiency

η_t

t is defined as product of η_n and η_m and determines difference between theoretical and actual required input power:

$$\eta_t = \eta_v \cdot \eta_m = \frac{P_{theor}}{P_{act.}} \quad [-]$$

$P_{act.}$ [kW] actual input power
 P_{theor} [kW] theoretical input power

WORKING LIQUID

- Mineral oils for hydraulic drives
- Hydraulic liquids based on plant oils suitable for hydraulic drives

Liquid temperature

- $t = -20 \div +80$ [°C]
when used with FKM (Viton) seal up to 120 [°C]

Cinematic viscosity

- Recommended (during continuous operation): $\nu = 20 \div 80 \cdot 10^{-6} [\text{m}^2 \cdot \text{s}^{-1}]$
- Maximum (cold starting, at viscosity >1000 , operating pressure <10 bar is permissible, speed $<1500 \cdot \text{min}^{-1}$): $\nu = 1200 \cdot 10^{-6} [\text{m}^2 \cdot \text{s}^{-1}]$
- Minimum (operating mode at $10 \cdot 10^{-6}$ up $20 \cdot 10^{-6}$ should be consulted with manufacturer): $\nu = 10 \cdot 10^{-6} [\text{m}^2 \cdot \text{s}^{-1}]$

Filtration coefficient β_α

$\beta_{25\ 75} \geq$ (for pressure $p_2 < 200$ bar)
 $\beta_{10\ 75} \geq$ (for pressure $p_2 > 200$ bar)

Liquid contamination class according to ISO 4406

21/18/15 (for pressure $p_2 < 200$ bar)
20/17/14 (for pressure $p_2 > 200$ bar)

Liquid contamination class according to NAS 1638

10 (for pressure $p_2 < 200$ bar)
8 (for pressure $p_2 > 200$ bar)

PRESSURE LOAD

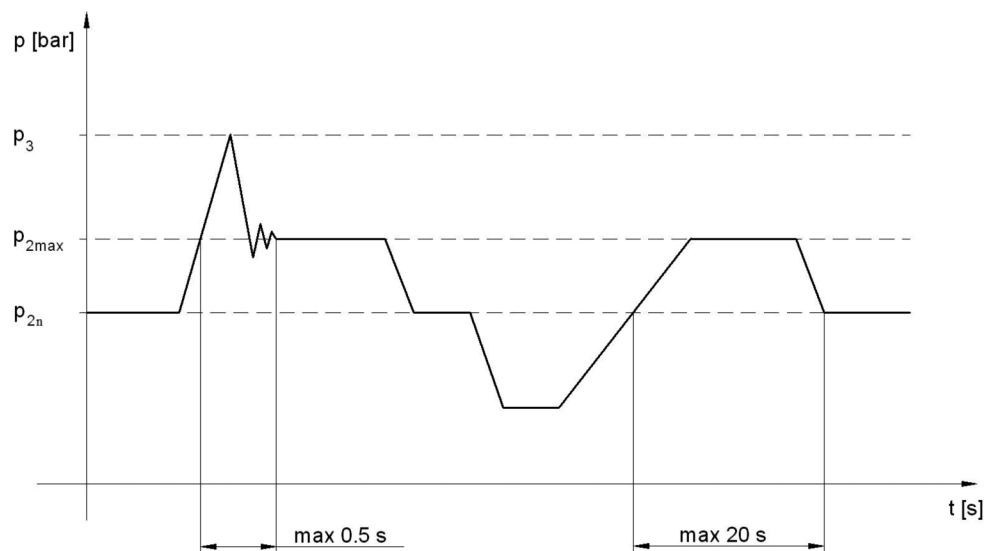

- p_{2n} **max. contin. pressure** Max. working pressure, at which the pump can be operated without time limitation.
- p_{2max} **max. pressure** Maximum pressure permissible for a short time, max. 20s.
- p_3 **peak pressure** Short-time pressure (fractions of a second) arising in case of a sudden change of the operating mode; any excess of this pressure during operation is impermissible.

DIRECTION OF ROTATION

- Determine direction of rotation by looking at the drive shaft. The pump can only be used in the specified direction of rotation.

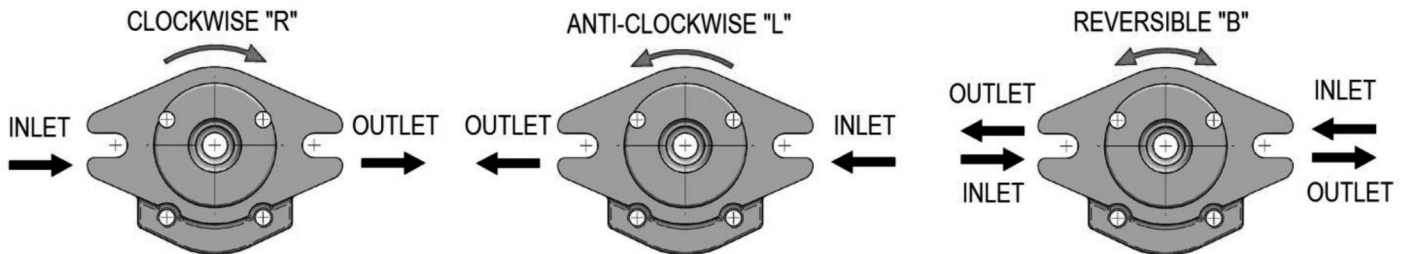

REVERSIBLE DESIGN

- The pumps with the possibility of bidirectional rotation have a different internal arrangement requiring drainage. Two types of drain are used - internal and external. The internal drainage is always interconnected with the outlet by means of valves. The external drainage is solved by an orifice located in the cover opposite the driven gear (see. picture below).

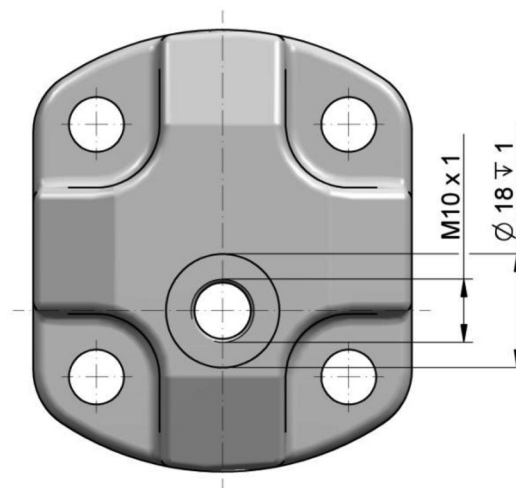

P23 FLOW RATE AND POWER CURVES

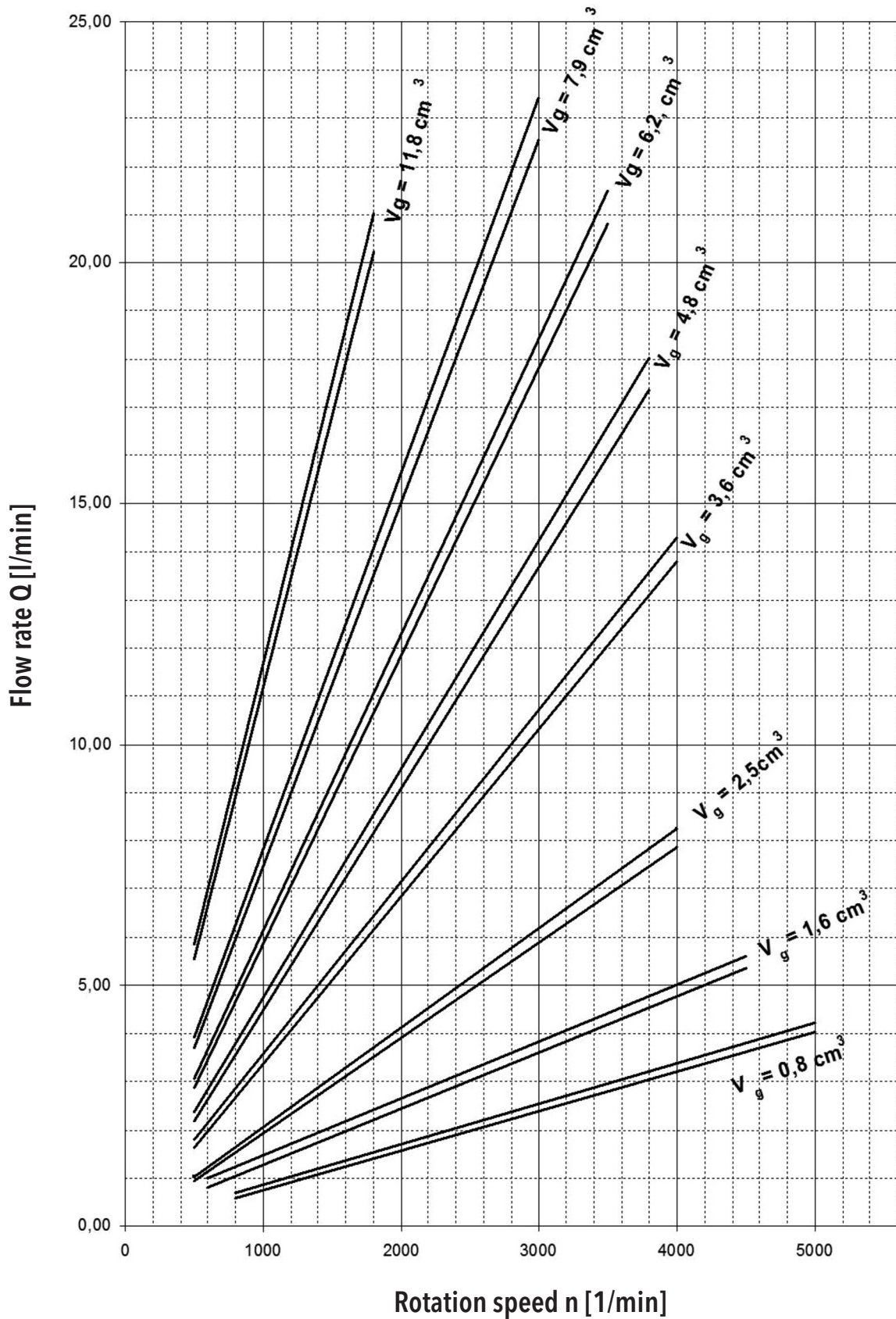

Above curves apply to ISO Vg 46 oil at temperature $t = 45^\circ\text{C}$.

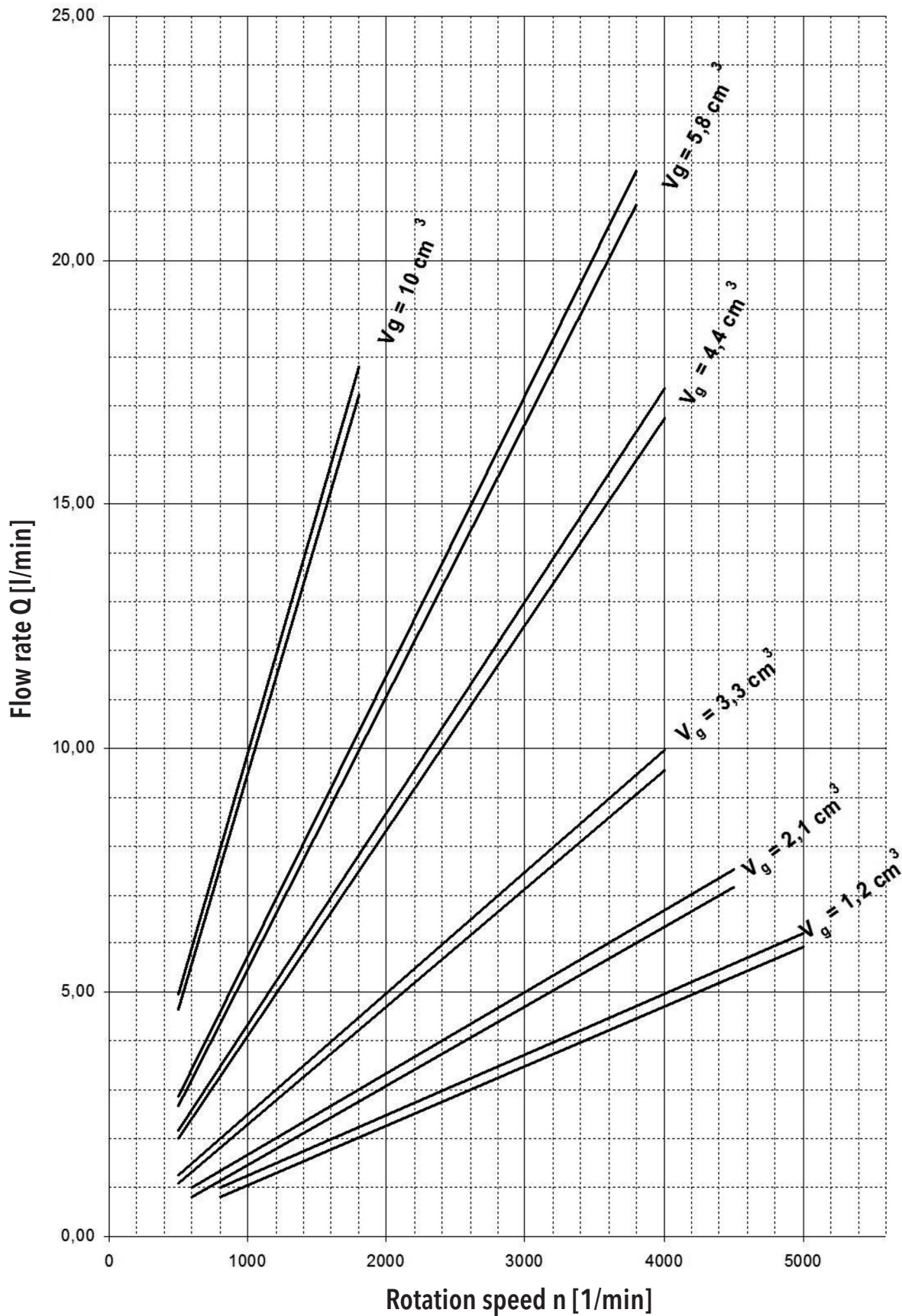

Above curves apply to ISO Vg 46 oil at temperature $t = 45^\circ\text{C}$.

0,80 cm³

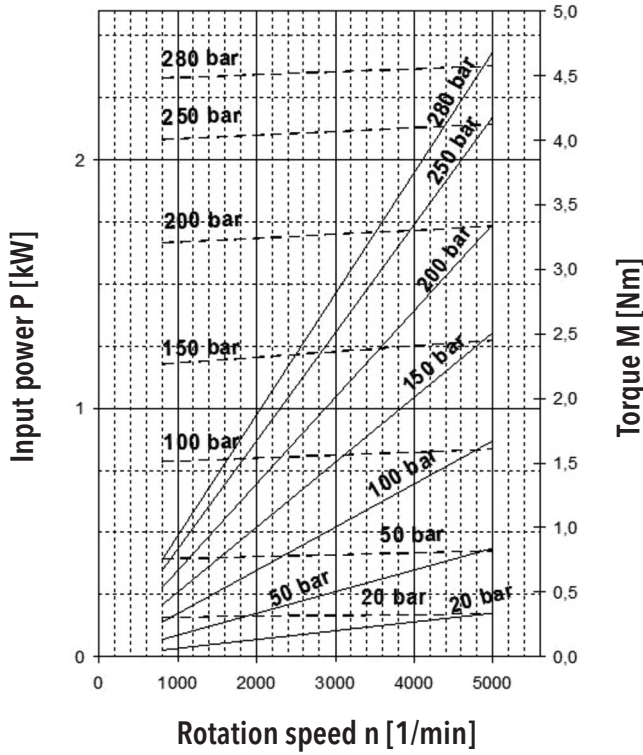

1,60 cm³

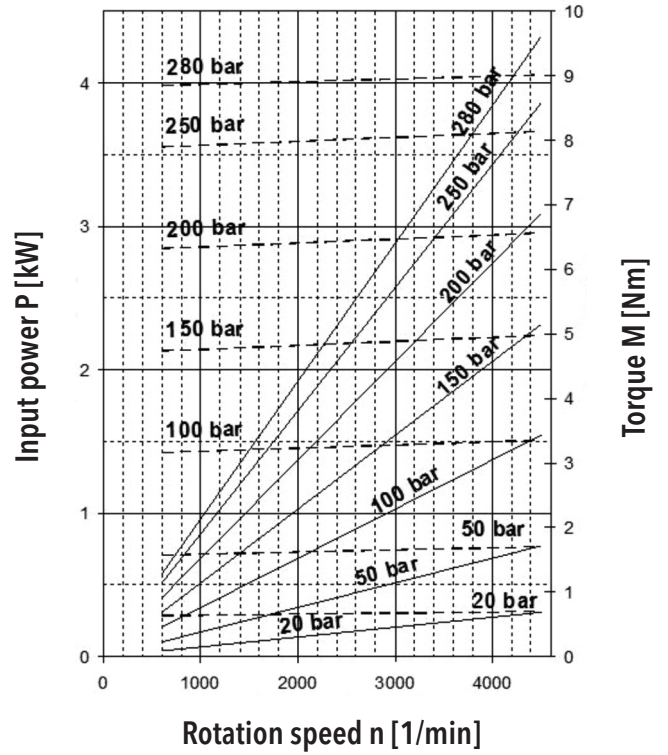

2,50 cm³

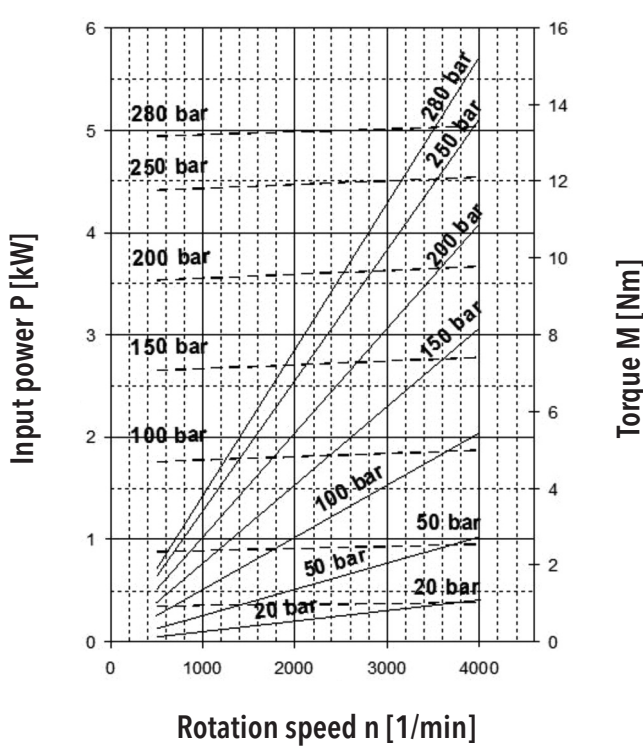

3,60 cm³

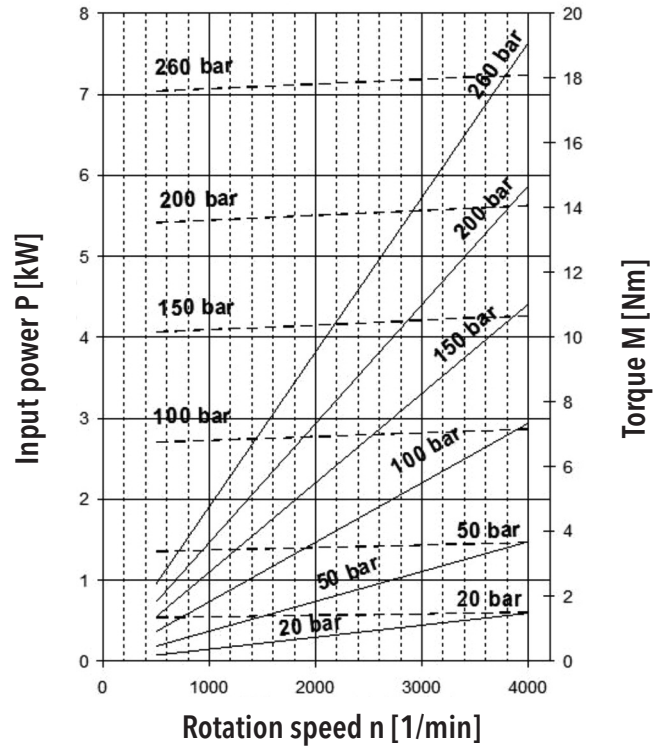

4,80 cm³

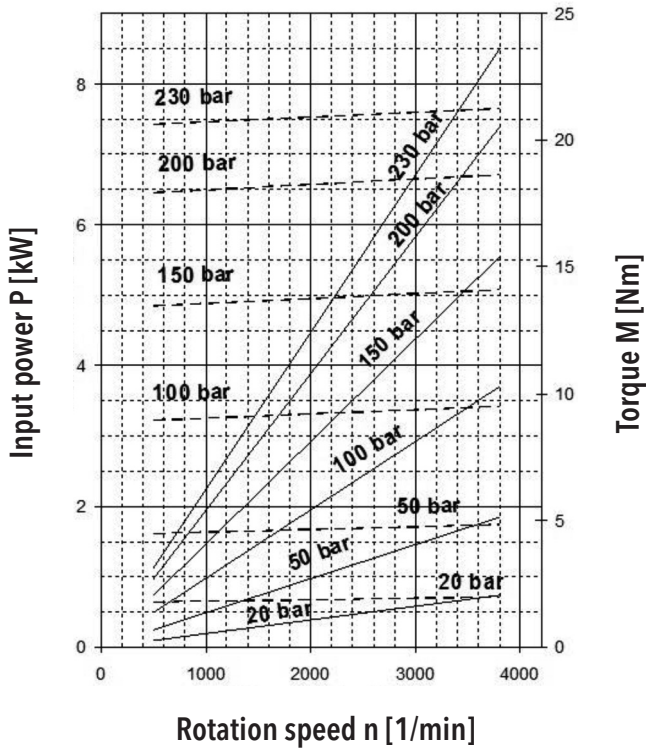

6,20 cm³

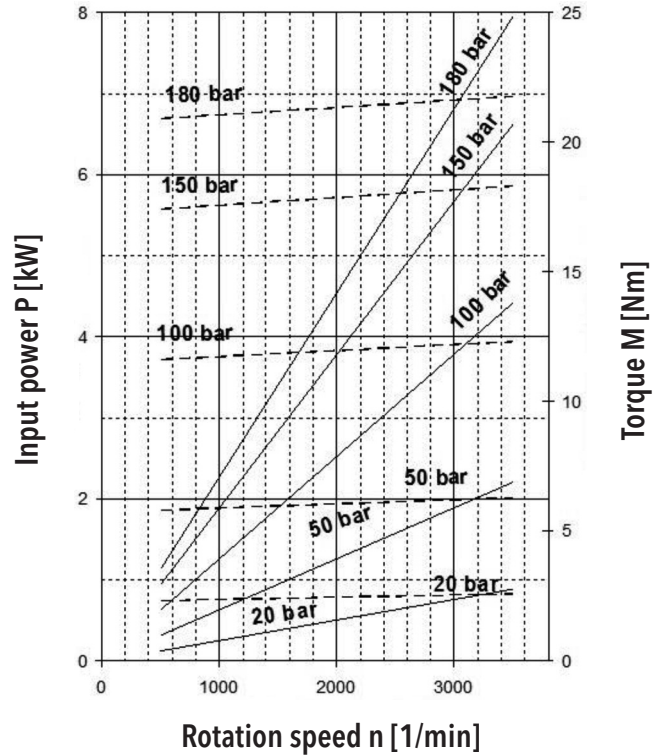

7,90 cm³

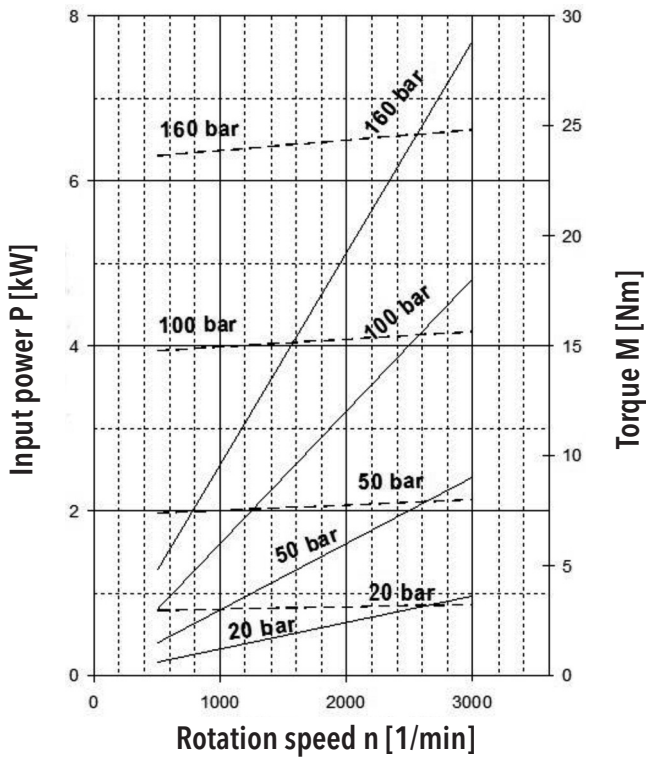

11,80 cm³

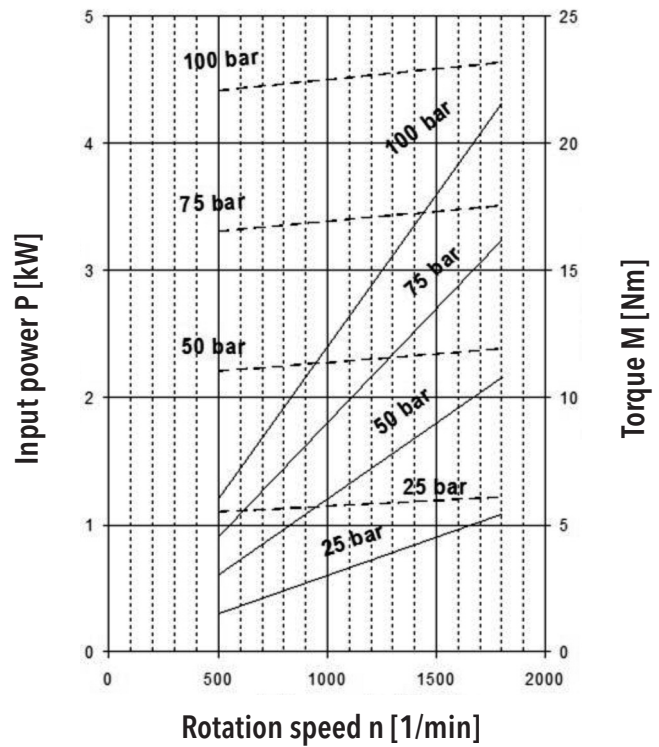







ORDER KEY - SINGLE VERSION







P23 - 3,3 R - S01 D01 - S G02 G01 - V . 004

Code	Type
P23	P23 Series Gear Pump

Code	Displacement [cm ³]
0,80	0,855
1,00	1,016
1,20	1,257
1,60	1,666
2,10	2,086
2,30	2,301
2,50	2,514
2,65	2,674
3,30	3,316
3,60	3,611
4,40	4,386
4,80	4,787
5,80	5,804
6,20	6,205
6,40	6,419
7,00	7,007
7,90	7,890
10,00	10,003
11,80	11,795
XX	Other displacements on request

Code	Direction of rotation
R	Clockwise
L	Anti-clockwise
B	Bi-directional











Code	Flange design
R02	 Rectangular flange, centre ring Ø25,4, Spacing screw 155 x 155
S01	 SAE A - A
A03	 Flange with through bolts, centre ring Ø32 with O-ring, (deep center ring 7)
A04	 Flange with through bolts, centre ring Ø32 with O-ring, (deep center ring 8)
A05	 Flange with through bolts, centre ring Ø32 with O-ring, (narrow desing)
A06	 Flange with through bolts, centre ring Ø32, (narrow desing)
Z	Special desing

Code	Location of inlets and outlets
S	 Side (in body)
R	 Axial (in cover)
F	 Axial (in flange)
A	 Axial (inlet in cover, outlet in flange)
C	 Combination (inlet in body, outlet in flange)
D	 Combination (inlet in cover, outlet in body)

Code	Special arrangements
-	No special arrangements
001	With front end bearing
002	With relief valve
004	Without shaft seal

Code	Seal material
N	NBR
V	FKM (VITON)
C	CR (CHLOROPREN)

Code	Liquid inlet and outlet connection shape
M02	Thread M 12x1,5
M03	Thread M 14x1,5
M05	Thread M 18x1,5
M06	Thread M 20x1,5
M07	Thread M 22x1,5
G01	Thread BSP G1/4
G02	Thread BSP G3/8
G03	Thread BSP G1/2
U02	Thread 9/16-18 UNF-2B
U03	Thread 3/4-16 UNF-2B
U04	Thread 7/8-14 UNF-2B
H01	Flanged fitting Ø8 Square 4xM5 Ø26
H02	Flanged fitting Ø10 Square 4xM5 Ø26
H03	Flanged fitting Ø8 Square 4xM6 Ø30
H04	Flanged fitting Ø12 Square 4xM6 Ø30
P01	Inlet / outlet in flange
Z	Special desing

Code	Drive shaft desing
C02	 Trapper 1:8 Key 2,5 x 3,7
C03	 Trapper 1:8 Key 2,4 x Ø13
C04	 Trapper 1:5 Key 2 x 2,6-D7
K03	 Cross coupling
K04	 Cross coupling
V02	 Cylindric Key 3h9x3x22
V03	 Cylindric Key 3,2x3,2x19,4
V04	 Cylindric Key 3m6x14
V05	 Cylindric Key 3h9x3x10
D01	 Involute spline
Z	Special desing

An example of designation for the P23 anti-clockwise pump with displacement of 4.4 cm³/rev, SAE A-A flange, trapper 1:8 with key 2.5x3.7, BSP side inlets and standard NBR seal without special arrangements: **P23-4.4L-S01C02-SG03G03-N**

ORDER KEY - MULTIPLE VERSION

P23 - 3,3 / 3,3 R - S01 D01 - S G02 G01 / G02 G01 - V . 004

Code	Type
P23	P23 Series Gear Pump

Code	Displacement [cm ³]
0,80	0,855
1,00	1,016
1,20	1,257
1,60	1,666
2,10	2,086
2,30	2,301
2,50	2,514
2,65	2,674
3,30	3,316
3,60	3,611
4,40	4,386
4,80	4,787
5,80	5,804
6,20	6,205
6,40	6,419
7,00	7,007
7,90	7,890
10,00	10,003
11,80	11,795
XX	Other displacements on request

Code	Direction of rotation
R	Clockwise
L	Anti-clockwise
B	Bi-directional

Code	Flange design	
R02		Rectangular flange, centre ring $\varnothing 25,4$, Spacing screw 155 x 155
S01		SAE A - A
A03		Flange with through bolts, centre ring $\varnothing 32$ with O-ring, (deep center ring 7)
A04		Flange with through bolts, centre ring $\varnothing 32$ with O-ring, (deep center ring 8)
A05		Flange with through bolts, centre ring $\varnothing 32$ with O-ring, (narrow desing)
A06		Flange with through bolts, centre ring $\varnothing 32$, (narrow desing)
Z		Special desing

Code	Location of inlets and outlets	
S		Side (in body)
C		Combination

Code	Special arrangements
-	No special arrangements
001	With front end bearing
002	With relief valve
004	Without shaft seal









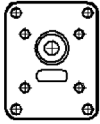
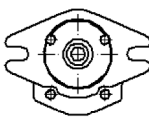
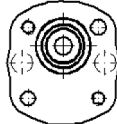
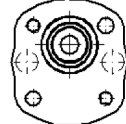

Code	Seal material
N	NBR
V	FKM (VITON)
C	CR (CHLOROPREN)

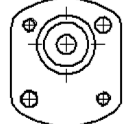
Code	Drive shaft desing	
C02		Traper 1:8 Key 2,5 x 3,7
C03		Traper 1:8 Key 2,4 x $\varnothing 13$
C04		Traper 1:5 Key 2 x 2,6-D7
K03		Cross coupling
K04		Cross coupling
V02		Cylindric Key 3h9x3x22
V03		Cylindric Key 3,2x3,2x19,4
V04		Cylindric Key 3m6x14
V05		Cylindric Key 3h9x3x10
D01		Involute spline
Z		Special desing

Code	Liquid inlet and outlet connection shape	
M02		Thread M 12x1,5
M03		Thread M 14x1,5
M05		Thread M 18x1,5
M06		Thread M 20x1,5
M07		Thread M 22x1,5
G01		Thread BSP G1/4
G02		Thread BSP G3/8
G03		Thread BSP G1/2
U02		Thread 9/16-18 UNF-2B
U03		Thread 3/4-16 UNF-2B
U04		Thread 7/8-14 UNF-2B
H01		Flanged fitting $\varnothing 8$ Square 4xM5 $\varnothing 26$
H02		Flanged fitting $\varnothing 10$ Square 4xM5 $\varnothing 26$
H03		Flanged fitting $\varnothing 8$ Square 4xM6 $\varnothing 30$
H04		Flanged fitting $\varnothing 12$ Square 4xM6 $\varnothing 30$
P01		Inlet / outlet in flange
Z		Special desing

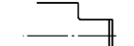
An example of designation for the P23 two-section clockwise pump with displacements of 4.4 and 3.3 cm³, rectangular flange, centre ring $\varnothing 25.4$, Trapper 1:8 with key 2.4x5 $\varnothing 13$, one common input and to outputs with metric threads, FKM sealing without special arrangements: **P23-4.4/3.3R-R02C03-SM05M05/NM05-V**

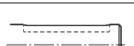
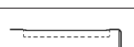
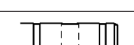
COMBINATIONS OF FLANGES AND SHAFTS

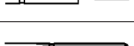
		FLANGE DESIGN						
		R02	S01	A03	A04	A05	A06	
								
DRIVE SHAFT	C02		●		●			
	C03		●		●	●		
	C04		●		●			
	K03				●		●	
	K04		○			●	●	●
	V02		○	●				
	V03			●				
	V04				●			
	V05		●					
	D01				●			

● - SUGGESTED ○ - POSSIBLE

FLANGES DESIGN

R02:

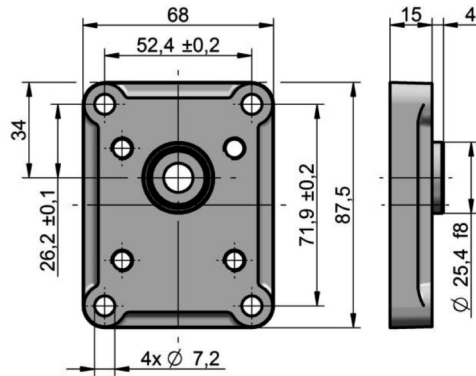

S01:

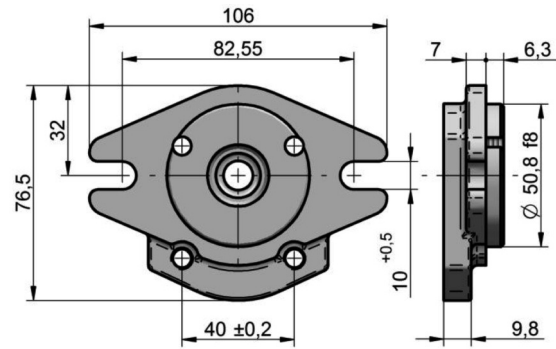

A03:

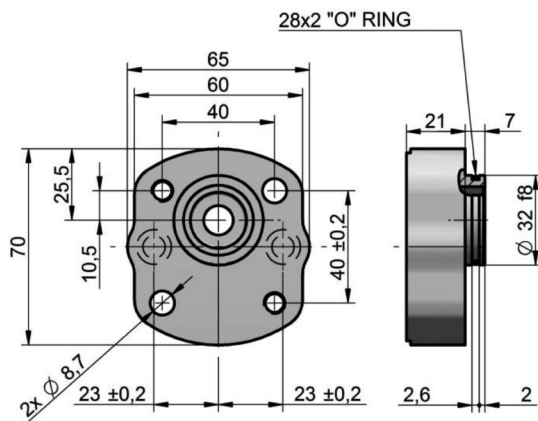

A04:

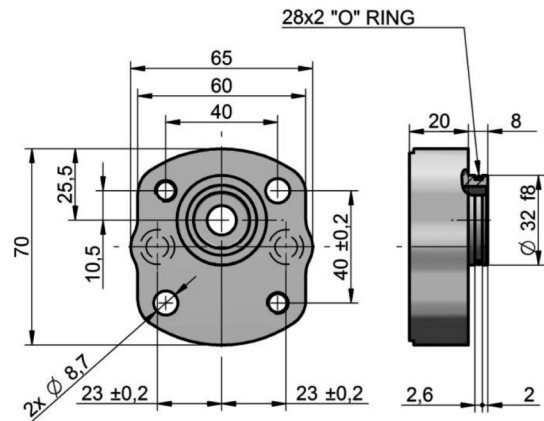

A05:

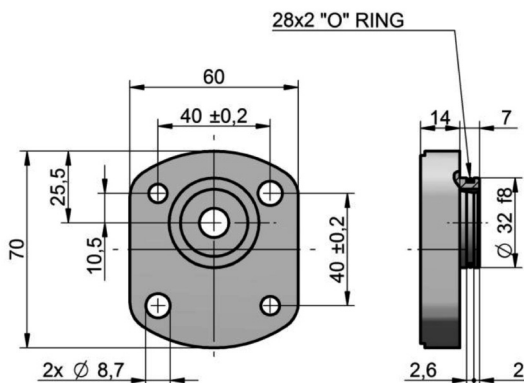

A06:

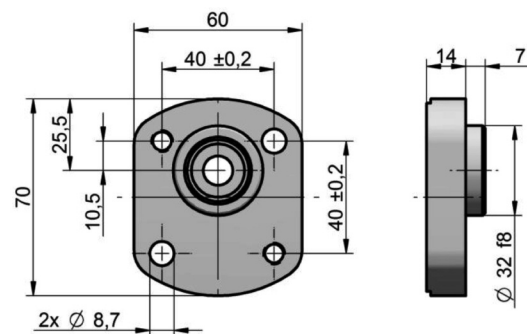

DRIVE SHAFTS

C02:

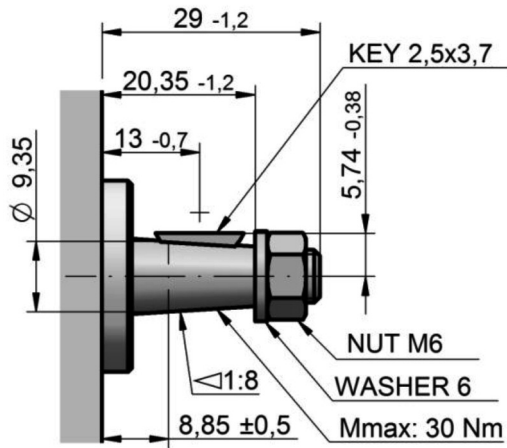

C03:

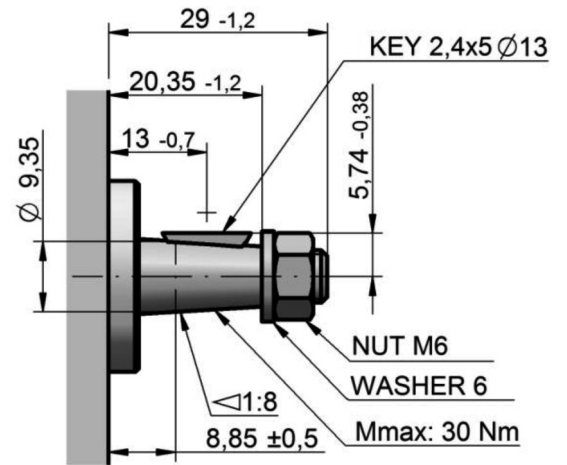

C04:

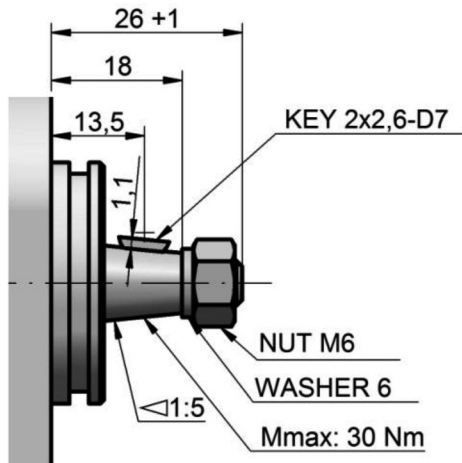

D01:

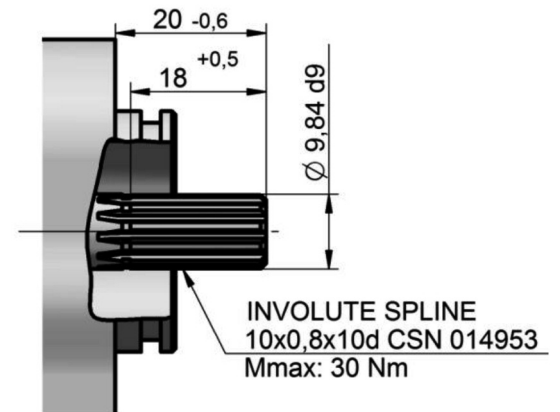

K03:

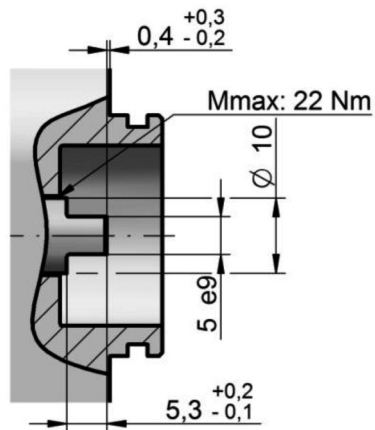

K04:

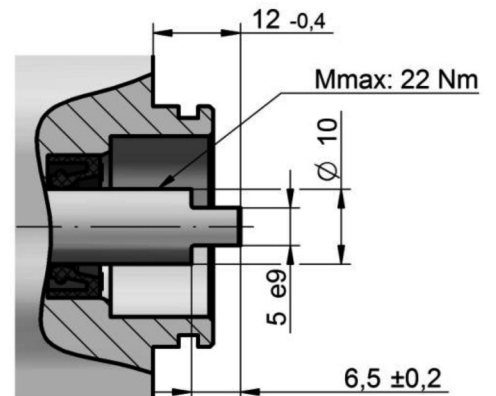

V02:

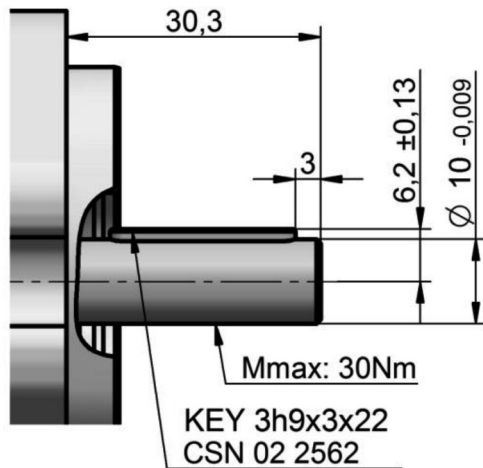

V03:

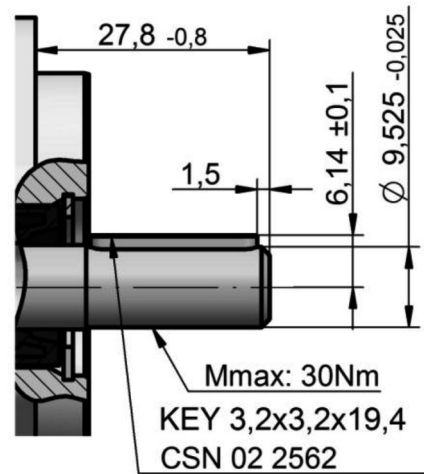

V04:

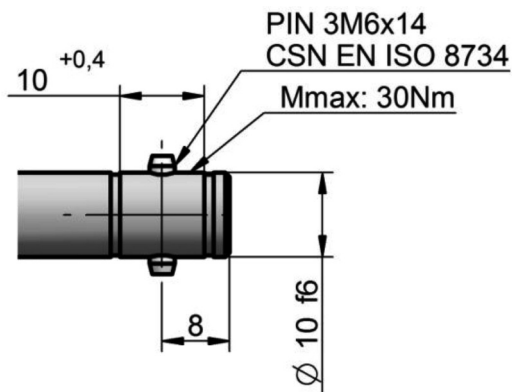

V05:

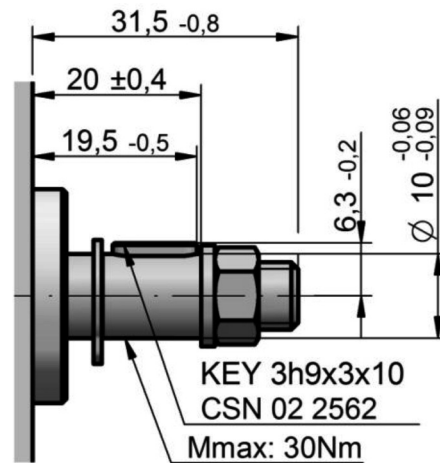

LIQUID INLET AND OUTLET CONNECTION

Metric thread according to ISO 6149

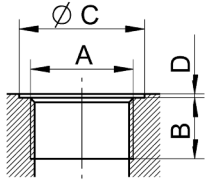

Displacement [cm ³]	Code	Inlet				Code	Outlet			
		A	B	C	D		A	B	C	D
all	M03	M 14x1.5	13	26	1	M02	M 12x1.5	12	20	1
0.8 - 3.3	M03	M 14x1.5	13	26	1	M03	M 14x1.5	13	26	1
all	M04	M 16x1.5	14	22	1	M04	M 16x1.5	14	22	1
all	M05	M 18x1.5	13	30	1	M05	M 18x1.5	13	30	1
all	M06	M 20x1.5	14	26	1	M02 - M05				
3.3 - 11.8	M07	M 22x1.5	13	35	1	M02 - M05				

BSPP pipe thread according to ISO 228-1

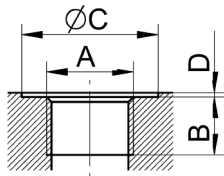

Displacement [cm ³]	kód	Inlet				kód	Outlet			
		A	B	C	D		A	B	C	D
all	G02	G 3/8"	13	24	1	G01	G 1/4"	13	26	1
all	G02	G 3/8"	13	24	1	G02	G 3/8"	13	24	1
all	G03	G 1/2"	13	34	1	G03	G 1/2"	13	34	1

UNF thread according to SAE

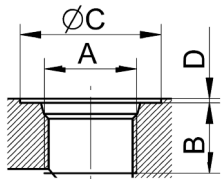

Displacement [cm ³]	kód	Inlet				kód	Outlet			
		A	B	C	D		A	B	C	D
all	U03	3/4-16 UNF	13	24.6	1	U02	9/16-18 UNF	13	24.6	1
all	U04	7/8-14 UNF	16	34.0	1	U03	3/4-16 UNF	13	30.0	1

Flanged fittings according to DIN 8901/8902

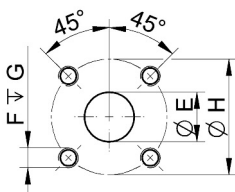

Displacement [cm ³]	kód	Inlet			kód	Outlet		
		A	B	C		A	B	C
all	H01	M5, depth 12	8	26	H01	M5, depth 12	8	26
all	H02	M5, depth 12	10	26	H02	M5, depth 12	10	26
all	H03	M6, depth 12	8	30	H03	M6, depth 12	8	30
all	H04	M6, depth 12	12	30	H04	M6, depth 12	12	30

NOTE: All inlets and outlets can be combination

Inlet / Outlet in flange

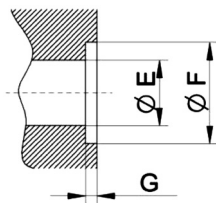

Code	Outlet		
	E	F	G
P01	8	12.4	1.4

Drains

Displacement [cm ³]	Code	Outlet			
		A	B	C	D
all	M01	M 10 x 1	8	15	1

CATALOGUE SHETS OF P23 SERIES BASIC DESIGNS

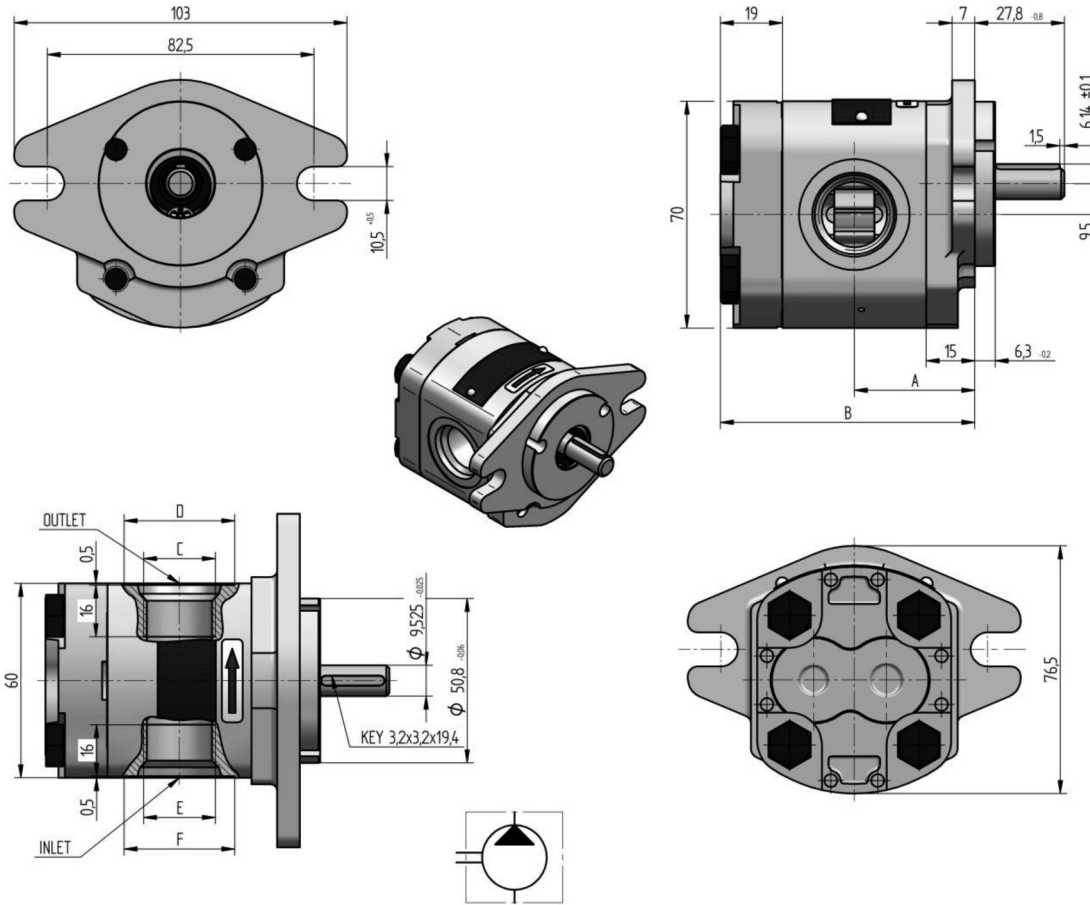

Order key	purch. code	direct. of rot.	displacement [cm ³ /1]	nom. press. [bar]	speed MIN. [min ⁻¹]	speed MAX. [min ⁻¹]	dimension					
							A [mm]	B [mm]	C [mm]	D [mm]	E [mm]	F [mm]
P23-7.9R- S01V03-SU04U04-N	187 9005	R	7.9	160	500	3 000	45.8	95.6	7/8-14 UNF-2B	Ø 34.2	7/8-14 UNF-2B	Ø 34.2
P23-7.9L- S01V03-SU04U04-N		L										
P23-6.2R- S01V03-SU04U04-N	187 9974	R	6.2	180	500	3 500	42.6	89.3	7/8-14 UNF-2B	Ø 34.2	7/8-14 UNF-2B	Ø 34.2
P23-6.2L- S01V03-SU04U04-N		L										
P23-5.8R- S01V03-SU04U04-N		R	5.8	200	50	3 500	41.9	87.8	7/8-14 UNF-2B	Ø 34.2	7/8-14 UNF-2B	Ø 34.2
P23-5.8L- S01V03-SU04U04-N		L										
P23-4.8R- S01V03-SU04U04-N	187 9880	R	4.8	230	500	3 800	40.0	84.0	7/8-14 UNF-2B	Ø 34.2	7/8-14 UNF-2B	Ø 34.2
P23-4.8L- S01V03-SU04U04-N		L										
P23-4.4R- S01V03-SU04U04-N	187 9879	R	4.4	250	500	4 000	39.2	82.5	7/8-14 UNF-2B	Ø 34.2	7/8-14 UNF-2B	Ø 34.2
P23-4.4L- S01V03-SU04U04-N		L										
P23-3.6R- S01V03-SU04U04-N	187 9878	R	3.6	260	500	4 000	37.8	79.6	7/8-14 UNF-2B	Ø 34.2	7/8-14 UNF-2B	Ø 34.2
P23-3.6L- S01V03-SU04U04-N		L										
P23-3.3R- S01V03-SU04U04-N	187 9877	R	3.3	280	500	4 000	37.2	78.5	7/8-14 UNF-2B	Ø 34.2	7/8-14 UNF-2B	Ø 34.2
P23-3.3L- S01V03-SU04U04-N		L										
P23-2.5R- S01V03-SU03U03-N	187 9876	R	2.5	280	500	4 500	35.7	75.5	3/4-16 UNF-2B	Ø 30.2	3/4-16 UNF-2B	Ø 30.2
P23-2.5L- S01V03-SU03U03-N		L										
P23-2.1R- S01V03-SU03U03-N	187 9875	R	2.1	280	600	4 500	34.9	73.9	3/4-16 UNF-2B	Ø 30.2	3/4-16 UNF-2B	Ø 30.2
P23-2.1L- S01V03-SU03U03-N		L										
P23-1.6R- S01V03-SU03U03-N	187 9874	R	1.6	280	600	5 000	34.1	72.3	3/4-16 UNF-2B	Ø 30.2	3/4-16 UNF-2B	Ø 30.2
P23-1.6L- S01V03-SU03U03-N		L										
P23-1.2R- S01V03-SU03U03-N	187 9873	R	1.2	280	600	5 000	33.4	70.8	3/4-16 UNF-2B	Ø 30.2	3/4-16 UNF-2B	Ø 30.2
P23-1.2L- S01V03-SU03U03-N		L										
P23-0.8R- S01V03-SU03U03-N	187 9872	R	0.8	280	800	5 000	32.6	69.3	3/4-16 UNF-2B	Ø 30.2	3/4-16 UNF-2B	Ø 30.2
P23-0.8L- S01V03-SU03U03-N		L										

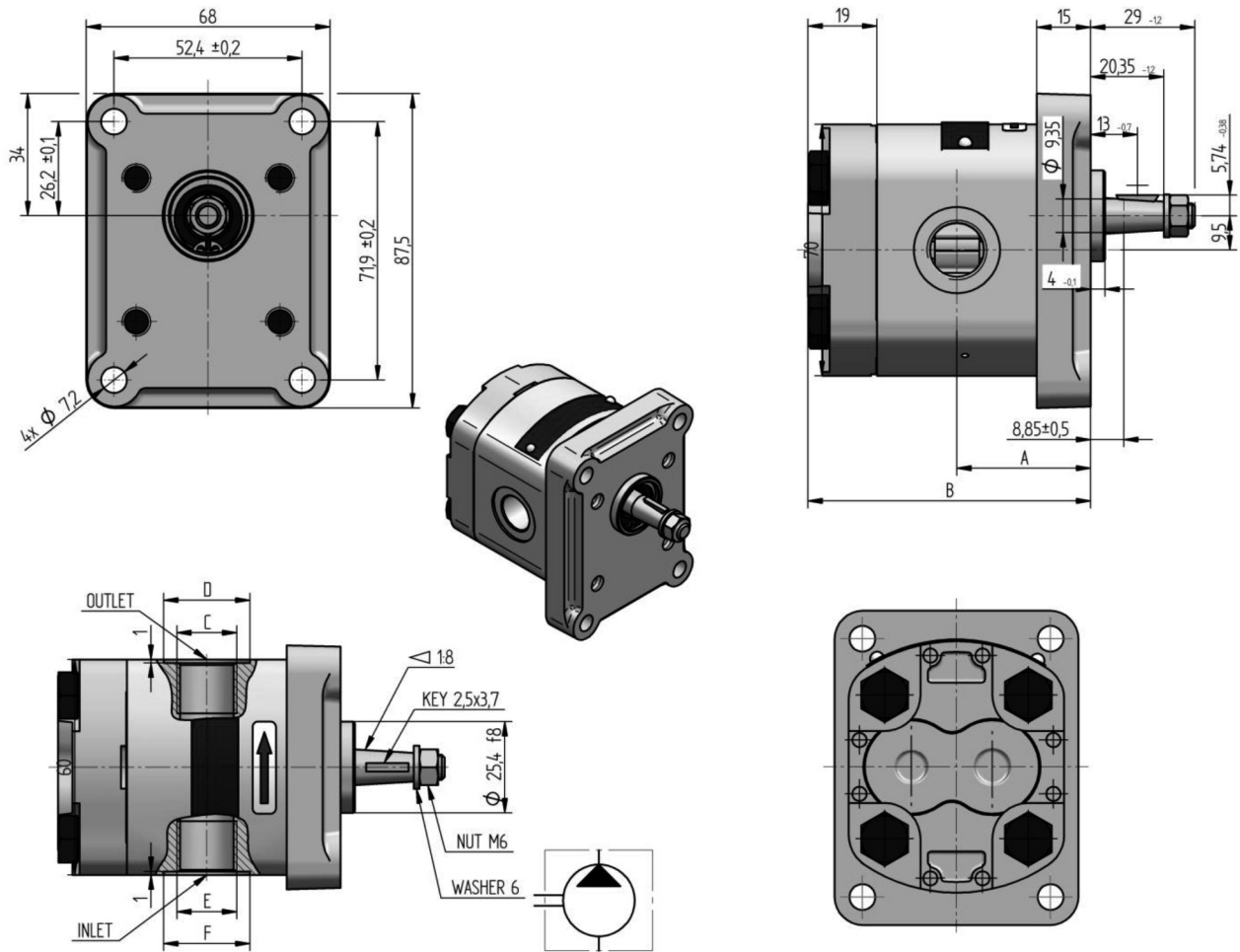

Order key	purch. code	direct. of rot.	displacement [cm ³ /1]	nom. press. [bar]	speed MIN. [min ⁻¹]	speed MAX. [min ⁻¹]	dimension					
							A [mm]	B [mm]	C [mm]	D [mm]	E [mm]	F [mm]
P23-7.9R- R02C02-SG02G02-N	187 9987	R	7.9	160	500	3 000	45.8	95.6	G 3/8	Ø 24	G 3/8	Ø 24
P23-7.9L- R02C02-SG02G02-N		L										
P23-6.2R- R02C02-SG02G02-N	187 9804	R	6.2	180	500	3 500	42.6	89.3	G 3/8	Ø 24	G 3/8	Ø 24
P23-6.2L- R02C02-SG02G02-N		L										
P23-5.8R- R02C02-SG02G02-N	187 9986	R	5.8	200	500	3 500	41.9	87.8	G 3/8	Ø 24	G 3/8	Ø 24
P23-5.8L- R02C02-SG02G02-N		L										
P23-4.8R- R02C02-SG02G02-N	187 9985	R	4.8	230	500	3 800	40.0	84.0	G 3/8	Ø 24	G 3/8	Ø 24
P23-4.8L- R02C02-SG02G02-N		L										
P23-4.4R- R02C02-SG02G02-N	187 9954	R	4.4	250	500	4 000	39.2	82.5	G 3/8	Ø 24	G 3/8	Ø 24
P23-4.4L- R02C02-SG02G02-N		L										
P23-3.6R- R02C02-SG02G02-N	187 9951	R	3.6	260	500	4 000	37.8	79.6	G 3/8	Ø 24	G 3/8	Ø 24
P23-3.6L- R02C02-SG02G02-N	187 9018	L										
P23-3.3R- R02C02-SG02G02-N	187 9984	R	3.3	280	500	4 000	37.2	78.5	G 3/8	Ø 24	G 3/8	Ø 24
P23-3.3L- R02C02-SG02G02-N		L										
P23-2.5R- R02C02-SG02G02-N	187 9950	R	2.5	280	500	4 500	35.7	75.5	G 3/8	Ø 24	G 3/8	Ø 24
P23-2.5L- R02C02-SG02G02-N		L										
P23-2.1R- R02C02-SG02G02-N	187 9983	R	2.1	280	600	4 500	34.9	73.9	G 3/8	Ø 24	G 3/8	Ø 24
P23-2.1L- R02C02-SG02G02-N		L										
P23-1.6R- R02C02-SG02G02-N	187 9890	R	1.6	280	600	5 000	34.1	72.3	G 3/8	Ø 24	G 3/8	Ø 24
P23-1.6L- R02C02-SG02G02-N		L										
P23-1.2R- R02C02-SG02G02-N	187 9903	R	1.2	280	600	5 000	33.4	70.8	G 3/8	Ø 24	G 3/8	Ø 24
P23-1.2L- R02C02-SG02G02-N		L										
P23-0.8R- R02C02-SG02G02-N	187 9982	R	0.8	280	800	5 000	32.6	69.3	G 3/8	Ø 24	G 3/8	Ø 24
P23-0.8L- R02C02-SG02G02-N		L										

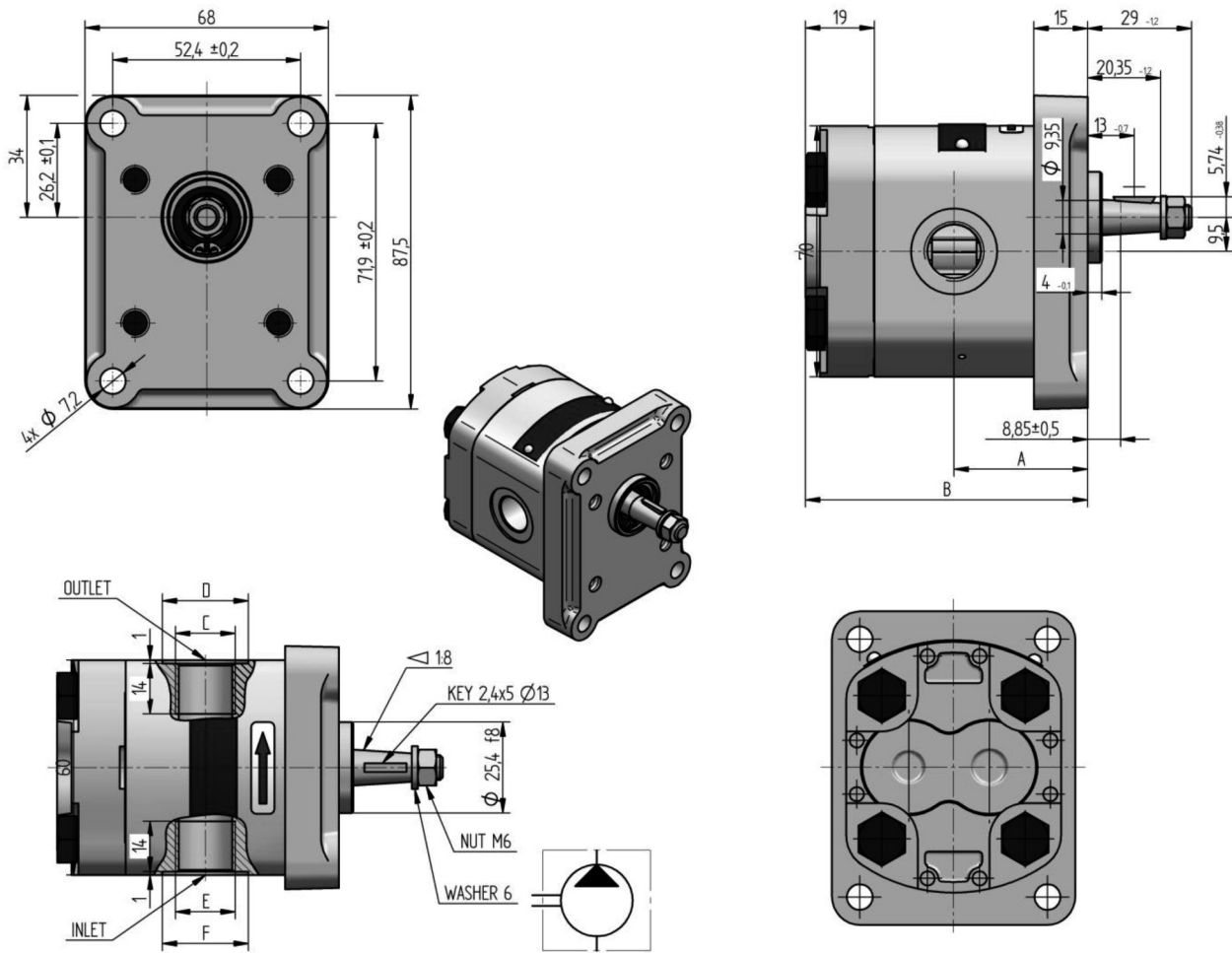

Order key	purch. code	direct. of rot.	displacement [cm ³ /1]	nom. press. [bar]	speed MIN. [min ⁻¹]	speed MAX. [min ⁻¹]	dimension					
							A [mm]	B [mm]	C [mm]	D [mm]	E [mm]	F [mm]
P23-7.9R- R02C03-SG02G02-N		R	7.9	160	500	3 000	45.8	95.6	G 3/8	Ø 24	G 3/8	Ø 24
P23-7.9L- R02C03-SG02G02-N		L										
P23-6.2R- R02C03-SG02G02-N	187 9959	R	6.2	180	500	3 500	42.6	89.3	G 3/8	Ø 24	G 3/8	Ø 24
P23-6.2L- R02C03-SG02G02-N	187 9720	L										
P23-5.8R- R02C03-SG02G02-N	187 9206	R	5.8	200	500	3 500	41.9	87.8	G 3/8	Ø 24	G 3/8	Ø 24
P23-5.8L- R02C03-SG02G02-N		L										
P23-4.8R- R02C03-SG02G02-N	187 9978	R	4.8	230	500	3 800	40.0	84.0	G 3/8	Ø 24	G 3/8	Ø 24
P23-4.8L- R02C03-SG02G02-N	187 9723	L										
P23-4.4R- R02C03-SG02G02-N	187 9993	R	4.4	250	500	4 000	39.2	82.5	G 3/8	Ø 24	G 3/8	Ø 24
P23-4.4L- R02C03-SG02G02-N		L										
P23-3.6R- R02C03-SG02G02-N		R	3.6	260	500	4 000	37.8	79.6	G 3/8	Ø 24	G 3/8	Ø 24
P23-3.6L- R02C03-SG02G02-N		L										
P23-3.3R- R02C03-SG02G02-N	187 9939	R	3.3	280	500	4 000	37.2	78.5	G 3/8	Ø 24	G 3/8	Ø 24
P23-3.3L- R02C03-SG02G02-N	187 9709	L										
P23-2.5R- R02C03-SG02G02-N	187 9968	R	2.5	280	500	4 500	35.7	75.5	G 3/8	Ø 24	G 3/8	Ø 24
P23-2.5L- R02C03-SG02G02-N	187 9990	L										
P23-2.1R- R02C03-SG02G02-N	187 9204	R	2.1	280	600	4 500	34.9	73.9	G 3/8	Ø 24	G 3/8	Ø 24
P23-2.1L- R02C03-SG02G02-N		L										
P23-1.6R- R02C03-SG02G02-N	187 9711	R	1.6	280	600	5 000	34.1	72.3	G 3/8	Ø 24	G 3/8	Ø 24
P23-1.6L- R02C03-SG02G02-N		L										
P23-1.2R- R02C03-SG02G02-N	187 9938	R	1.2	280	600	5 000	33.4	70.8	G 3/8	Ø 24	G 3/8	Ø 24
P23-1.2L- R02C03-SG02G02-N	187 9710	L										
P23-0.8R- R02C03-SG02G02-N	187 9203	R	0.8	280	800	5 000	32.6	69.3	G 3/8	Ø 24	G 3/8	Ø 24
P23-0.8L- R02C03-SG02G02-N		L										

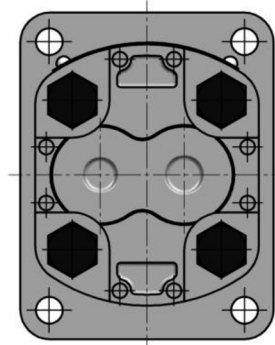
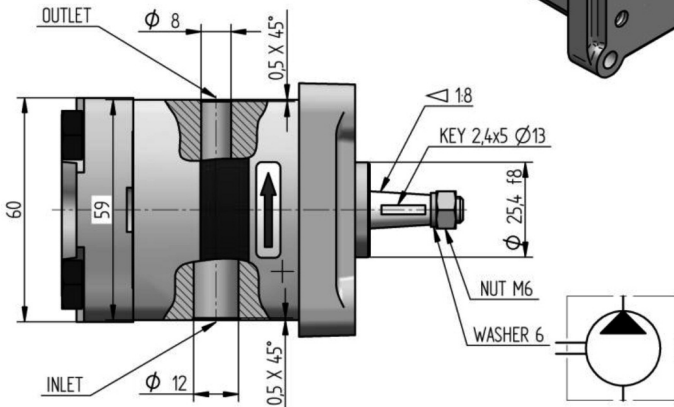
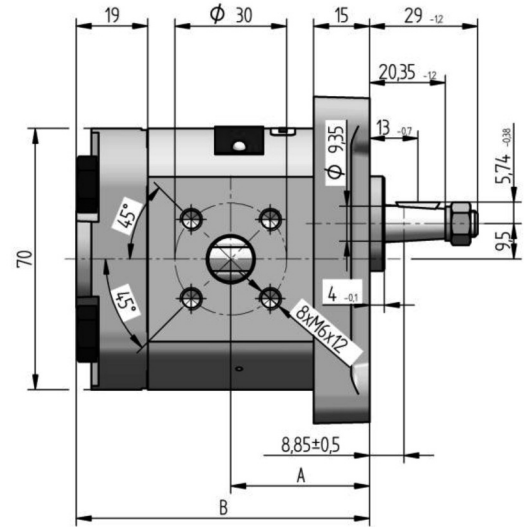
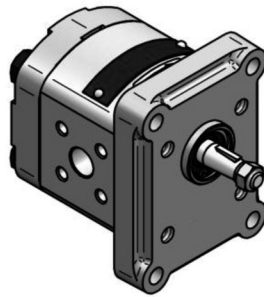
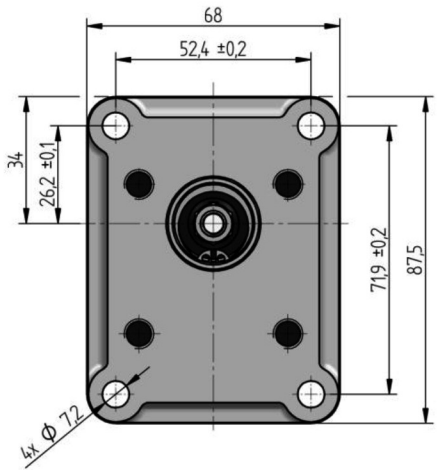

Order key	purch. code	direct. of rot.	displacement [cm ³ /1]	nom. press. [bar]	speed MIN. [min ⁻¹]	speed MAX. [min ⁻¹]	dimension	
							A [mm]	B [mm]
P23-7.9R-R02C03-SH04H03-N	187 9946	R	7.9	160	500	3 000	45.8	95.6
P23-7.9L-R02C03-SH04H03-N	187 9948	L						
P23-6.2R-R02C03-SH04H03-N	187 9980	R	6.2	180	500	3 500	42.6	89.3
P23-6.2L-R02C03-SH04H03-N	187 9963	L						
P23-5.8R-R02C03-SH04H03-N	187 9971	R	5.8	200	500	3 500	41.9	87.8
P23-5.8L-R02C03-SH04H03-N	187 9973	L						
P23-4.8R-R02C03-SH04H03-N	187 9958	R	4.8	230	500	3 800	40.0	84.0
P23-4.8L-R02C03-SH04H03-N	187 9947	L						
P23-4.4R-R02C03-SH04H03-N	187 9941	R	4.4	250	500	4 000	39.2	82.5
P23-4.4L-R02C03-SH04H03-N	187 9962	L						
P23-3.6R-R02C03-SH04H03-N	187 9945	R	3.6	260	500	4 000	37.8	79.6
P23-3.6L-R02C03-SH04H03-N	187 9972	L						
P23-3.3R-R02C03-SH04H03-N	187 9957	R	3.3	280	500	4 000	37.2	78.5
P23-3.3L-R02C03-SH04H03-N	187 9981	L						
P23-2.5R-R02C03-SH04H03-N	187 9940	R	2.5	280	500	4 500	35.7	75.5
P23-2.5L-R02C03-SH04H03-N	187 9961	L						
P23-2.1R-R02C03-SH04H03-N	187 9970	R	2.1	280	600	4 500	34.9	73.9
P23-2.1L-R02C03-SH04H03-N	187 9728	L						
P23-1.6R-R02C03-SH04H03-N	187 9969	R	1.6	280	600	5 000	34.1	72.3
P23-1.6L-R02C03-SH04H03-N	187 9762	L						
P23-1.2R-R02C03-SH04H03-N	187 9979	R	1.2	280	600	5 000	33.4	70.8
P23-1.2L-R02C03-SH04H03-N		L						
P23-0.8R-R02C03-SH04H03-N		R	0.8	280	800	5 000	32.6	69.3
P23-0.8L-R02C03-SH04H03-N		L						

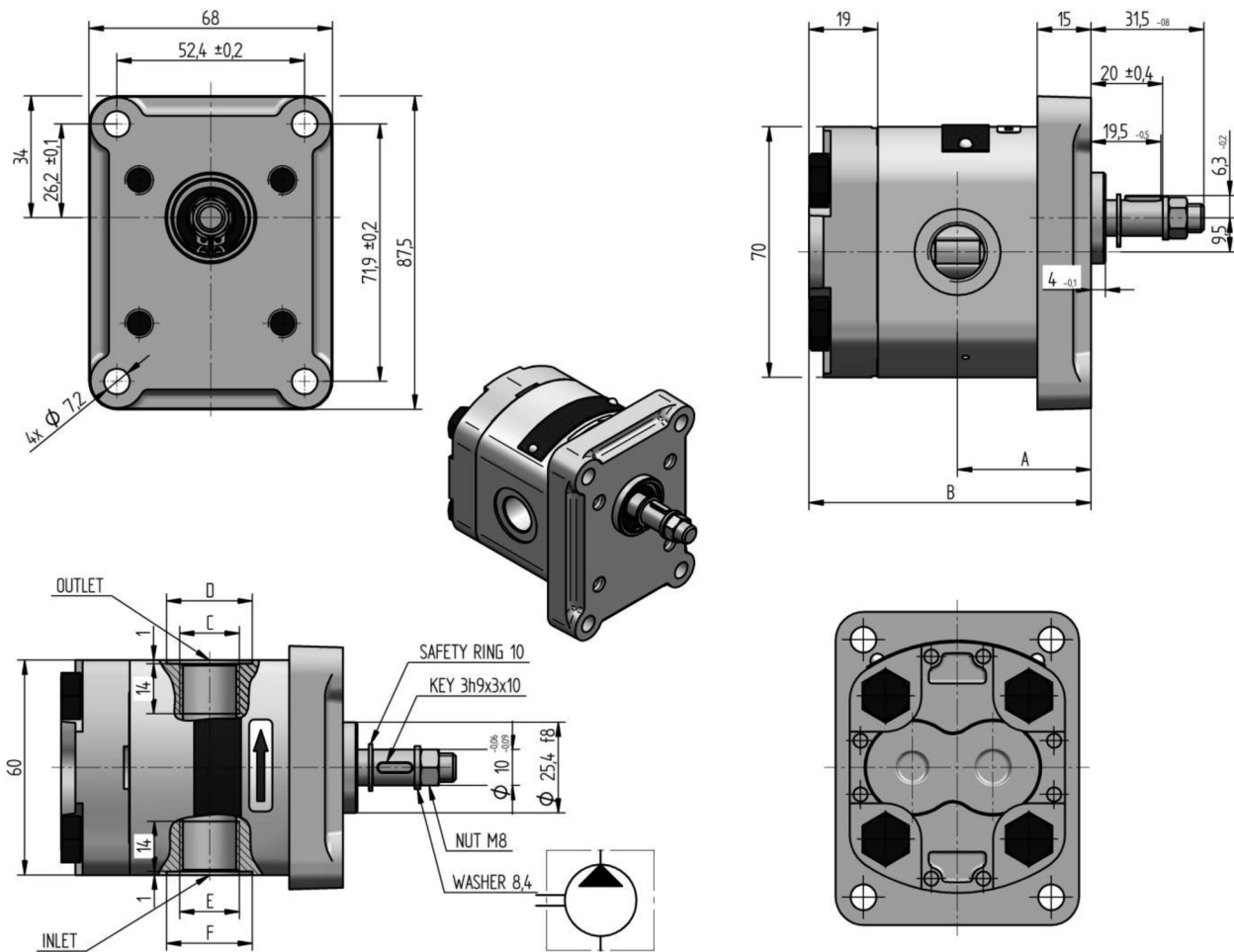

Order key	purch. code	direct. of rot.	displacement [cm ³ /1]	nom. press. [bar]	speed MIN. [min ⁻¹]	speed MAX. [min ⁻¹]	dimension					
							A [mm]	B [mm]	C [mm]	D [mm]	E [mm]	F [mm]
P23-7.9R- R02V05-SG02G02-N	187 9838	R	7.9	160	500	3 000	45.8	95.6	G 3/8	Ø 24	G 3/8	Ø 24
P23-7.9L- R02V05-SG02G02-N		L										
P23-6.2R- R02V05-SG02G02-N	187 9837	R	6.2	180	500	3 500	42.6	89.3	G 3/8	Ø 24	G 3/8	Ø 24
P23-6.2L- R02V05-SG02G02-N		L										
P23-5.8R- R02V05-SG02G02-N	187 9836	R	5.8	200	500	3 500	41.9	87.8	G 3/8	Ø 24	G 3/8	Ø 24
P23-5.8L- R02V05-SG02G02-N		L										
P23-4.8R- R02V05-SG02G02-N	187 9835	R	4.8	230	500	3 800	40.0	84.0	G 3/8	Ø 24	G 3/8	Ø 24
P23-4.8L- R02V05-SG02G02-N		L										
P23-4.4R- R02V05-SG02G02-N	187 9834	R	4.4	250	500	4 000	39.2	82.5	G 3/8	Ø 24	G 3/8	Ø 24
P23-4.4L- R02V05-SG02G02-N		L										
P23-3.6R- R02V05-SG02G02-N	187 9833	R	3.6	260	500	4 000	37.8	79.6	G 3/8	Ø 24	G 3/8	Ø 24
P23-3.6L- R02V05-SG02G02-N		L										
P23-3.3R- R02V05-SG02G02-N	187 9832	R	3.3	280	500	4 000	37.2	78.5	G 3/8	Ø 24	G 3/8	Ø 24
P23-3.3L- R02V05-SG02G02-N		L										
P23-2.5R- R02V05-SG02G02-N	187 9831	R	2.5	280	500	4 500	35.7	75.5	G 3/8	Ø 24	G 3/8	Ø 24
P23-2.5L- R02V05-SG02G02-N		L										
P23-2.1R- R02V05-SG02G02-N	187 9830	R	2.1	280	600	4 500	34.9	73.9	G 3/8	Ø 24	G 3/8	Ø 24
P23-2.1L- R02V05-SG02G02-N		L										
P23-1.6R- R02V05-SG02G02-N	187 9829	R	1.6	280	600	5 000	34.1	72.3	G 3/8	Ø 24	G 3/8	Ø 24
P23-1.6L- R02V05-SG02G02-N		L										
P23-1.2R- R02V05-SG02G02-N	187 9828	R	1.2	280	600	5 000	33.4	70.8	G 3/8	Ø 24	G 3/8	Ø 24
P23-1.2L- R02V05-SG02G02-N		L										
P23-0.8R- R02V05-SG02G02-N	187 9827	R	0.8	280	800	5 000	32.6	69.3	G 3/8	Ø 24	G 3/8	Ø 24
P23-0.8L- R02V05-SG02G02-N		L										

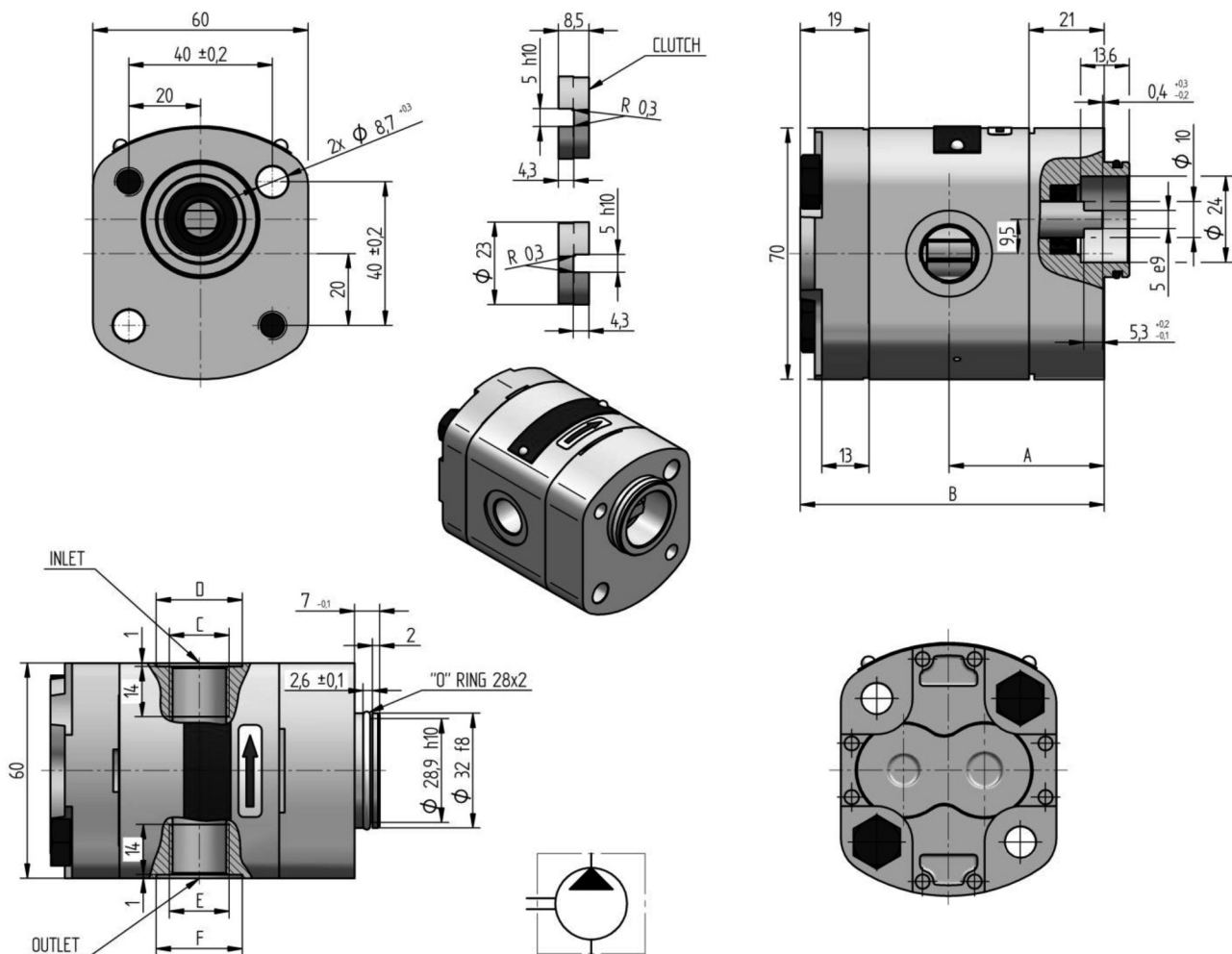

Order key	purch. code	direct. of rot.	displacement [cm ³ /1]	nom. press. [bar]	speed MIN. [min ⁻¹]	speed MAX. [min ⁻¹]	dimension					
							A [mm]	B [mm]	C [mm]	D [mm]	E [mm]	F [mm]
P23-7.9R- A03K03-SG02G02-N	187 9955	R	7.9	160	500	3 000	51.8	101.6	G 3/8	Ø 24	G 3/8	Ø 24
P23-7.9L- A03K03-SG02G02-N		L										
P23-6.2R- A03K03-SG02G02-N	187 9733	R	6.2	180	500	3 500	48.6	95.3	G 3/8	Ø 24	G 3/8	Ø 24
P23-6.2L- A03K03-SG02G02-N		L										
P23-5.8R- A03K03-SG02G02-N	187 9004	R	5.8	200	500	3 500	47.9	93.8	G 3/8	Ø 24	G 3/8	Ø 24
P23-5.8L- A03K03-SG02G02-N		L										
P23-4.8R- A03K03-SG02G02-N	187 9732	R	4.8	230	500	3 800	46.0	90.0	G 3/8	Ø 24	G 3/8	Ø 24
P23-4.8L- A03K03-SG02G02-N		L										
P23-4.4R- A03K03-SG02G02-N	187 9412	R	4.4	250	500	4 000	45.2	88.5	G 3/8	Ø 24	G 3/8	Ø 24
P23-4.4L- A03K03-SG02G02-N		L										
P23-3.6R- A03K03-SG02G02-N	187 9735	R	3.6	260	500	4 000	43.8	85.6	G 3/8	Ø 24	G 3/8	Ø 24
P23-3.6L- A03K03-SG02G02-N		L										
P23-3.3R- A03K03-SG02G02-N	187 9724	R	3.3	280	500	4 000	43.2	84.5	G 3/8	Ø 24	G 3/8	Ø 24
P23-3.3L- A03K03-SG02G02-N		L										
P23-2.5R- A03K03-SG02G02-N	187 9751	R	2.5	280	500	4 500	41.7	81.5	G 3/8	Ø 24	G 3/8	Ø 24
P23-2.5L- A03K03-SG02G02-N		L										
P23-2.1R- A03K03-SG02G02-N	187 9991	R	2.1	280	600	4 500	40.9	79.9	G 3/8	Ø 24	G 3/8	Ø 24
P23-2.1L- A03K03-SG02G02-N	187 9966	L										
P23-1.6R- A03K03-SG02G02-N		R	1.6	280	600	5 000	40.1	78.3	G 3/8	Ø 24	G 3/8	Ø 24
P23-1.6L- A03K03-SG02G02-N		L										
P23-1.2R- A03K03-SG02G02-N		R	1.2	280	600	5 000	39.4	76.8	G 3/8	Ø 24	G 3/8	Ø 24
P23-1.2L- A03K03-SG02G02-N		L										
P23-0.8R- A03K03-SG02G02-N		R	0.8	280	800	5 000	38.6	75.3	G 3/8	Ø 24	G 3/8	Ø 24
P23-0.8L- A03K03-SG02G02-N		L										

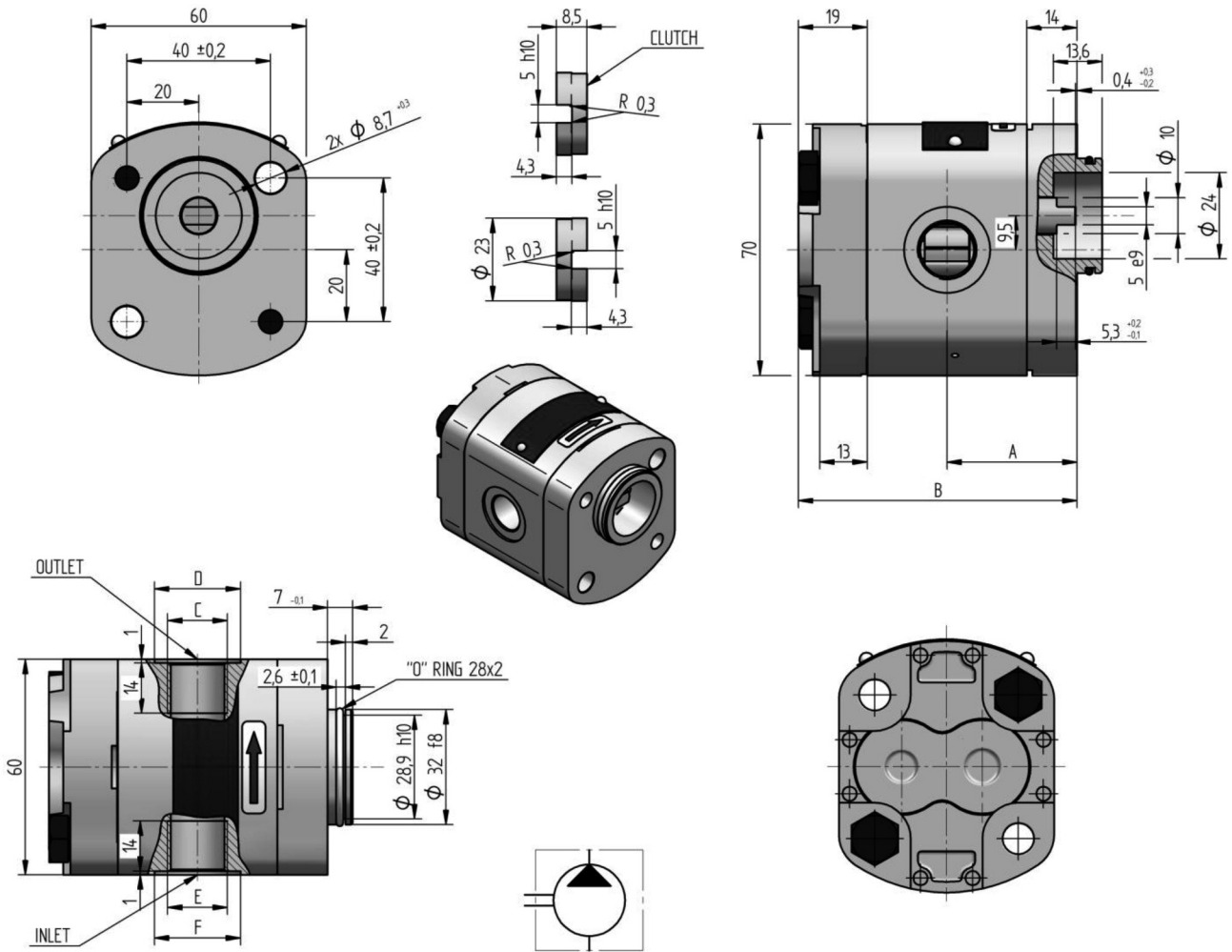

Order key	purch. code	direct. of rot.	displacement [cm ³ /1]	nom. press. [bar]	speed MIN. [min ⁻¹]	speed MAX. [min ⁻¹]	dimension					
							A [mm]	B [mm]	C [mm]	D [mm]	E [mm]	F [mm]
P23-7.9R-A05K03-SG02G02-N.004	187 9800	R	7.9	160	500	3 000	44.8	94.6	G 3/8	Ø 24	G 3/8	Ø 24
P23-7.9L-A05K03-SG02G02-N.004		L										
P23-6.2R-A05K03-SG02G02-N.004	187 9801	R	6.2	180	500	3 500	41.6	88.3	G 3/8	Ø 24	G 3/8	Ø 24
P23-6.2L-A05K03-SG02G02-N.004		L										
P23-5.8R-A05K03-SG02G02-N.004	187 9826	R	5.8	200	500	3 500	40.9	86.8	G 3/8	Ø 24	G 3/8	Ø 24
P23-5.8L-A05K03-SG02G02-N.004		L										
P23-4.8R-A05K03-SG02G02-N.004	187 9818	R	4.8	230	500	3 800	39.0	83.0	G 3/8	Ø 24	G 3/8	Ø 24
P23-4.8L-A05K03-SG02G02-N.004		L										
P23-4.4R-A05K03-SG02G02-N.004	187 9817	R	4.4	250	500	4 000	38.2	81.5	G 3/8	Ø 24	G 3/8	Ø 24
P23-4.4L-A05K03-SG02G02-N.004	187 9820	L										
P23-3.6R-A05K03-SG02G02-N.004	187 9816	R	3.6	260	500	4 000	36.8	78.6	G 3/8	Ø 24	G 3/8	Ø 24
P23-3.6L-A05K03-SG02G02-N.004		L										
P23-3.3R-A05K03-SG02G02-N.004	187 9815	R	3.3	280	500	4 000	36.2	77.5	G 3/8	Ø 24	G 3/8	Ø 24
P23-3.3L-A05K03-SG02G02-N.004		L										
P23-2.5R-A05K03-SG02G02-N.004	187 9814	R	2.5	280	500	4 500	34.7	74.5	G 3/8	Ø 24	G 3/8	Ø 24
P23-2.5L-A05K03-SG02G02-N.004	187 9819	L										
P23-2.1R-A05K03-SG02G02-N.004	187 9813	R	2.1	280	600	4 500	33.9	72.9	G 3/8	Ø 24	G 3/8	Ø 24
P23-2.1L-A05K03-SG02G02-N.004	187 9956	L										
P23-1.6R-A05K03-SG02G02-N.004	187 9812	R	1.6	280	600	5 000	33.1	71.3	G 3/8	Ø 24	G 3/8	Ø 24
P23-1.6L-A05K03-SG02G02-N.004		L										
P23-1.2R-A05K03-SG02G02-N.004	187 9825	R	1.2	280	600	5 000	32.4	69.8	G 3/8	Ø 24	G 3/8	Ø 24
P23-1.2L-A05K03-SG02G02-N.004		L										
P23-0.8R-A05K03-SG02G02-N.004	187 9824	R	0.8	280	800	5 000	31.6	68.3	G 3/8	Ø 24	G 3/8	Ø 24
P23-0.8L-A05K03-SG02G02-N.004		L										

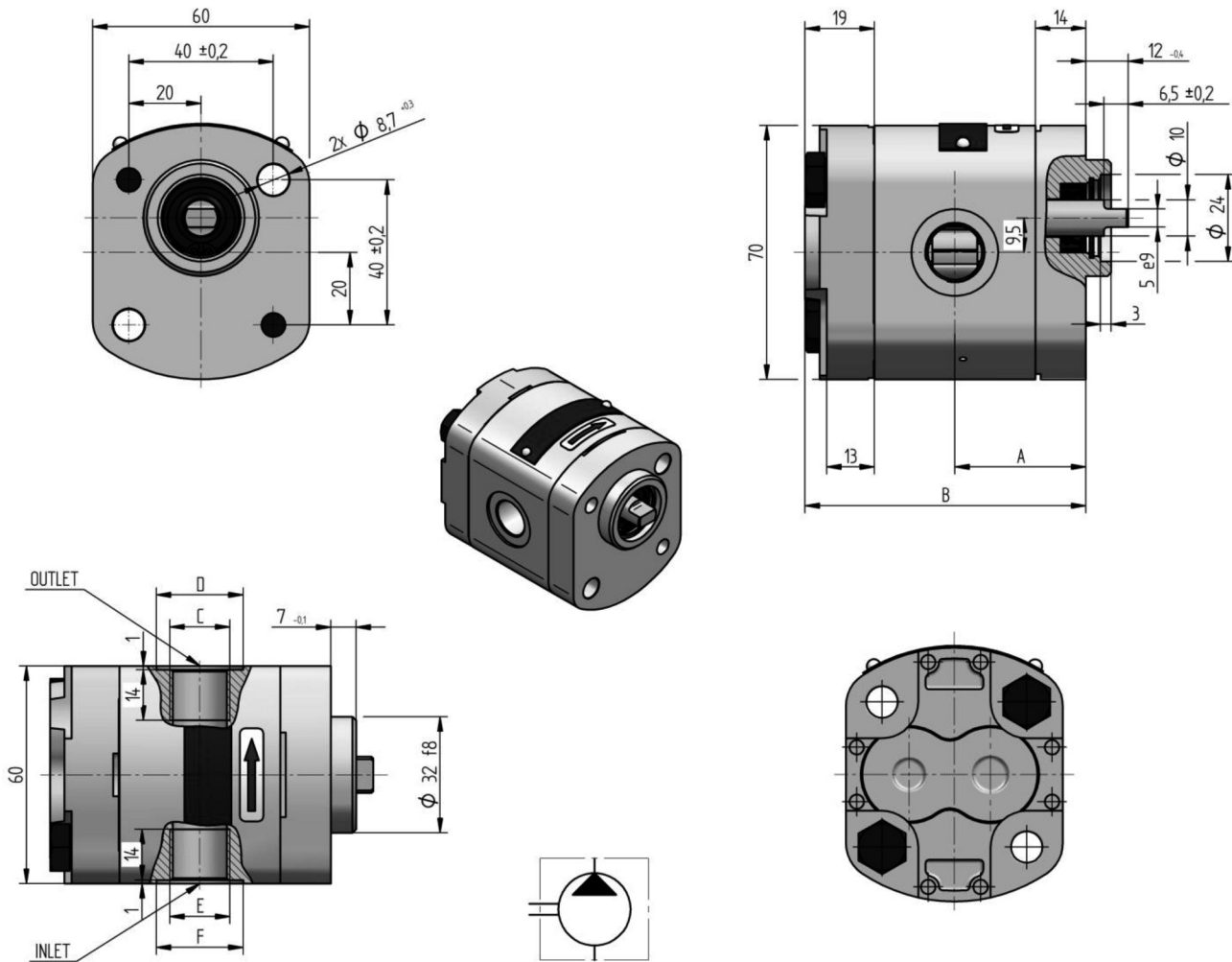

Order key	purch. code	direct. of rot.	displacement [cm ³ /1]	nom. press. [bar]	speed MIN. [min ⁻¹]	speed MAX. [min ⁻¹]	dimension					
							A [mm]	B [mm]	C [mm]	D [mm]	E [mm]	F [mm]
P23-7.9R- A06K04-SG02G02-N		R	7.9	160	500	3 000	44.8	94.6	G 3/8	Ø 24	G 3/8	Ø 24
P23-7.9L- A06K04-SG02G02-N		L										
P23-6.2R- A06K04-SG02G02-N		R	6.2	180	500	3 500	41.6	88.3	G 3/8	Ø 24	G 3/8	Ø 24
P23-6.2L- A06K04-SG02G02-N		L										
P23-5.8R- A06K04-SG02G02-N		R	5.8	200	500	3 500	40.9	86.8	G 3/8	Ø 24	G 3/8	Ø 24
P23-5.8L- A06K04-SG02G02-N		L										
P23-4.8R- A06K04-SG02G02-N		R	4.8	230	500	3 800	39.0	83.0	G 3/8	Ø 24	G 3/8	Ø 24
P23-4.8L- A06K04-SG02G02-N		L										
P23-4.4R- A06K04-SG02G02-N	187 9944	R	4.4	250	500	4 000	38.2	81.5	G 3/8	Ø 24	G 3/8	Ø 24
P23-4.4L- A06K04-SG02G02-N		L										
P23-3.6R- A06K04-SG02G02-N		R	3.6	260	500	4 000	36.8	78.6	G 3/8	Ø 24	G 3/8	Ø 24
P23-3.6L- A06K04-SG02G02-N		L										
P23-3.3R- A06K04-SG02G02-N		R	3.3	280	500	4 000	36.2	77.5	G 3/8	Ø 24	G 3/8	Ø 24
P23-3.3L- A06K04-SG02G02-N		L										
P23-2.5R- A06K04-SG02G02-N	187 9943	R	2.5	280	500	4 500	34.7	74.5	G 3/8	Ø 24	G 3/8	Ø 24
P23-2.5L- A06K04-SG02G02-N		L										
P23-2.1R- A06K04-SG02G02-N	187 9942	R	2.1	280	600	4 500	33.9	72.9	G 3/8	Ø 24	G 3/8	Ø 24
P23-2.1L- A06K04-SG02G02-N		L										
P23-1.6R- A06K04-SG02G02-N		R	1.6	280	600	5 000	33.1	71.3	G 3/8	Ø 24	G 3/8	Ø 24
P23-1.6L- A06K04-SG02G02-N		L										
P23-1.2R- A06K04-SG02G02-N		R	1.2	280	600	5 000	32.4	69.8	G 3/8	Ø 24	G 3/8	Ø 24
P23-1.2L- A06K04-SG02G02-N		L										
P23-0.8R- A06K04-SG02G02-N		R	0.8	280	800	5 000	31.6	68.3	G 3/8	Ø 24	G 3/8	Ø 24
P23-0.8L- A06K04-SG02G02-N		L										

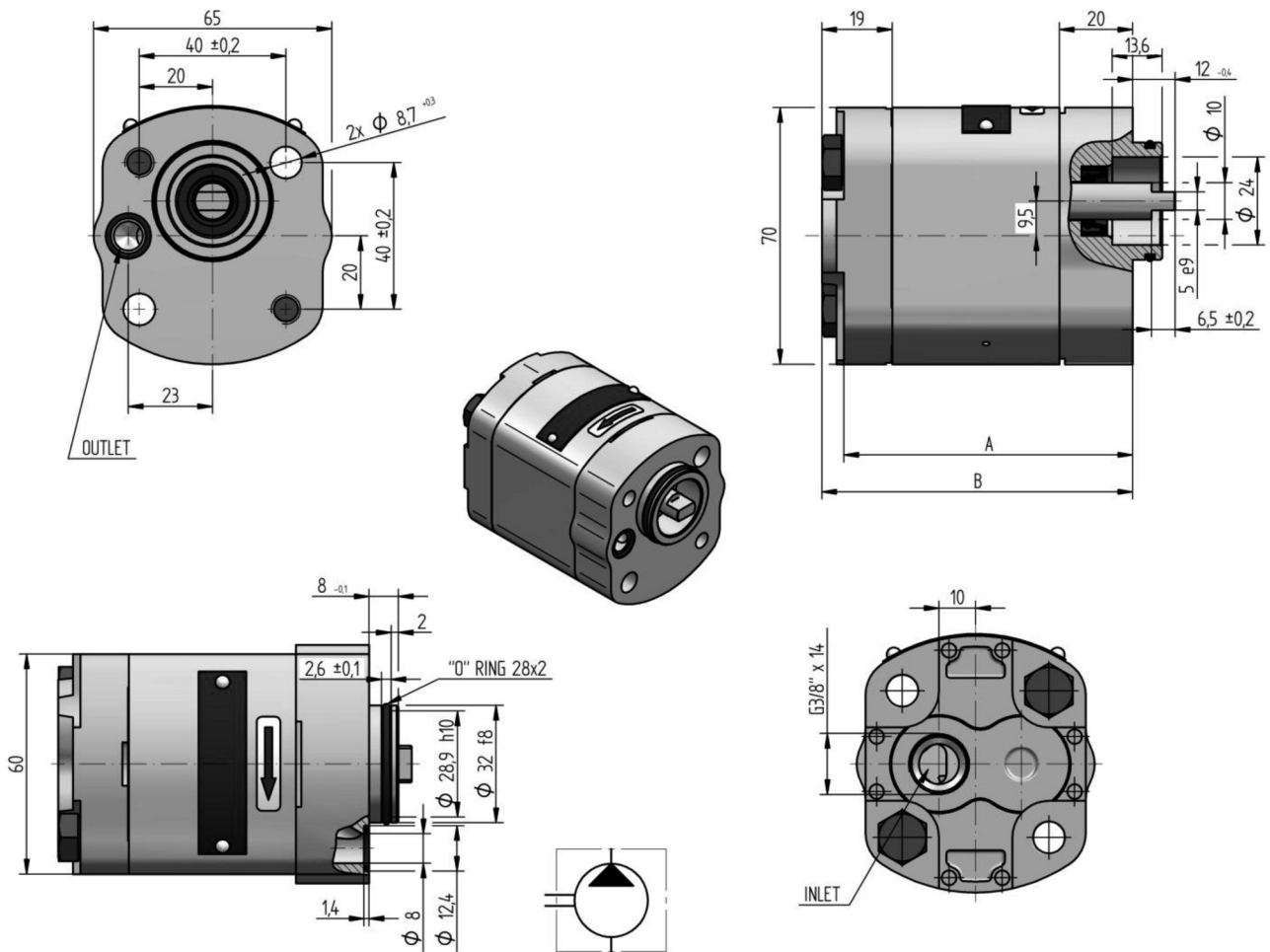

Order key	purch. code	direct. of rot.	displacement [cm ³ /1]	nom. press. [bar]	speed MIN. [min ⁻¹]	speed MAX. [min ⁻¹]	dimension	
							A [mm]	B [mm]
P23-7.9L-A04K04-AG02P01-N	187 9905	R L	7.9	160	500	3 000	94.6	100.6
P23-6.2L-A04K04-AG02P01-N	187 9989	R L	6.2	180	500	3 500	88.3	94.3
P23-5.8L-A04K04-AG02P01-N	187 9904	R L	5.8	200	500	3 500	86.8	92.8
P23-4.8L-A04K04-AG02P01-N	187 9976	R L	4.8	230	500	3 800	83.0	89.0
P23-4.4L-A04K04-AG02P01-N	187 9977	R L	4.4	250	500	4 000	81.5	87.5
P23-3.6L-A04K04-AG02P01-N	187 9921	R L	3.6	260	500	4 000	78.6	84.6
P23-3.3L-A04K04-AG02P01-N	187 9920	R L	3.3	280	500	4 000	77.5	83.5
P23-2.5L-A04K04-AG02P01-N	187 9919	R L	2.5	280	500	4 500	74.5	80.5
P23-2.1L-A04K04-AG02P01-N	187 9975	R L	2.1	280	600	4 500	72.9	78.9
P23-1.6L-A04K04-AG02P01-N	187 9918	R L	1.6	280	600	5 000	71.3	77.3
P23-1.2L-A04K04-AG02P01-N	187 9953	R L	1.2	280	600	5 000	69.8	75.8
P23-0.8L-A04K04-AG02P01-N	187 9952	R L	0.8	280	800	5 000	68.3	74.3

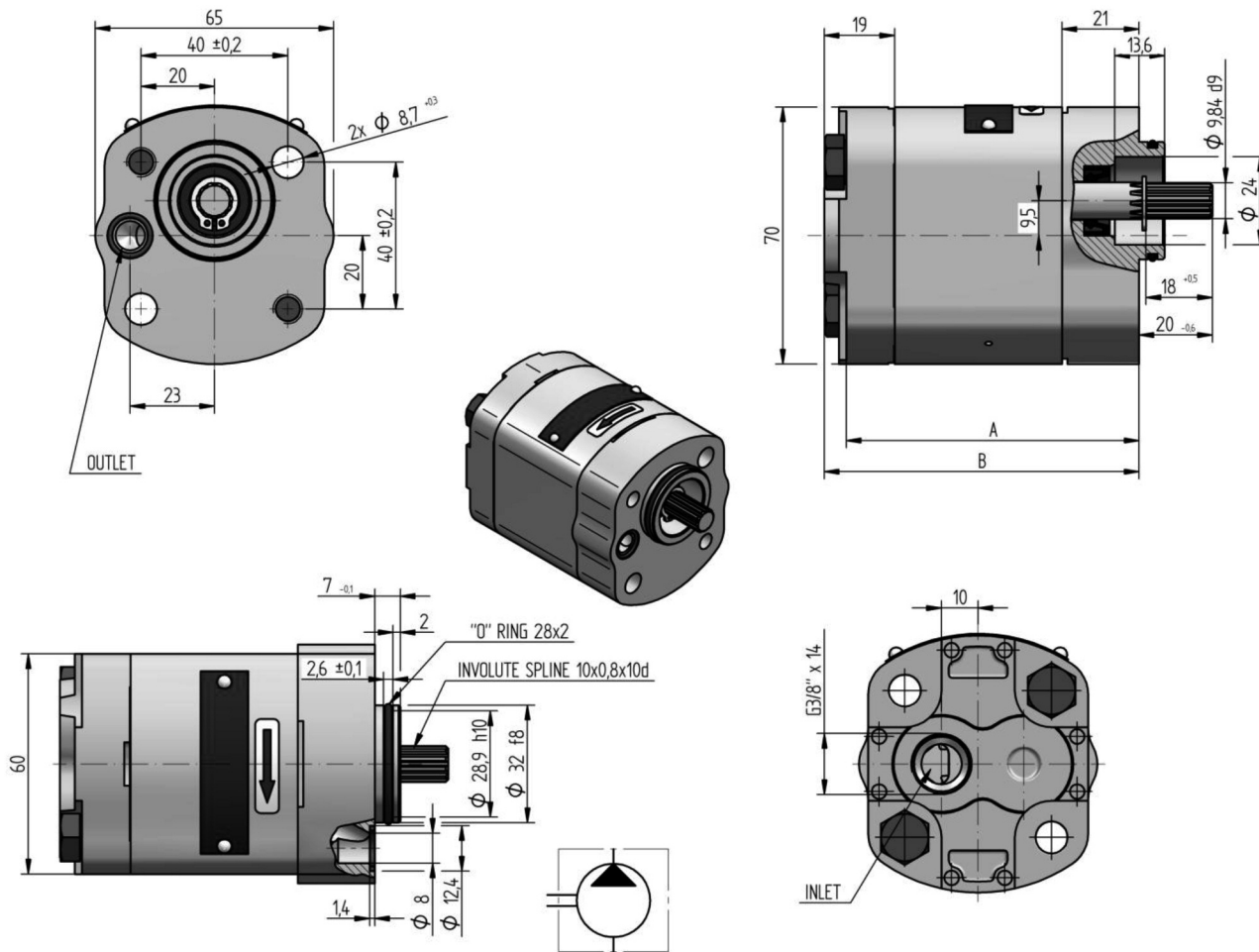

Order key	purch. code	direct. of rot.	displacement [cm ³ /1]	nom. press. [bar]	speed MIN. [min ⁻¹]	speed MAX. [min ⁻¹]	dimension	
							A [mm]	B [mm]
P23-7.9L- A03D01-AG02P01-N	187 9917	R L	7.9	160	500	3 000	95.6	101.6
P23-6.2L- A03D01-AG02P01-N	187 9916	R L	6.2	180	500	3 500	89.3	95.3
P23-5.8L- A03D01-AG02P01-N	187 9915	R L	5.8	200	500	3 500	87.8	93.8
P23-4.8L- A03D01-AG02P01-N	187 9914	R L	4.8	230	500	3 800	84.0	90.0
P23-4.4L- A03D01-AG02P01-N	187 9913	R L	4.4	250	500	4 000	82.5	88.5
P23-3.6L- A03D01-AG02P01-N	187 9912	R L	3.6	260	500	4 000	79.6	85.6
P23-3.3L- A03D01-AG02P01-N	187 9911	R L	3.3	280	500	4 000	78.5	84.5
P23-2.5L- A03D01-AG02P01-N	187 9910	R L	2.5	280	500	4 500	75.5	81.5
P23-2.1L- A03D01-AG02P01-N	187 9909	R L	2.1	280	600	4 500	73.9	79.9
P23-1.6L- A03D01-AG02P01-N	187 9908	R L	1.6	280	600	5 000	72.3	78.3
P23-1.2L- A03D01-AG02P01-N	187 9907	R L	1.2	280	600	5 000	70.8	76.8
P23-0.8L- A03D01-AG02P01-N	187 9906	R L	0.8	280	800	5 000	69.3	75.3

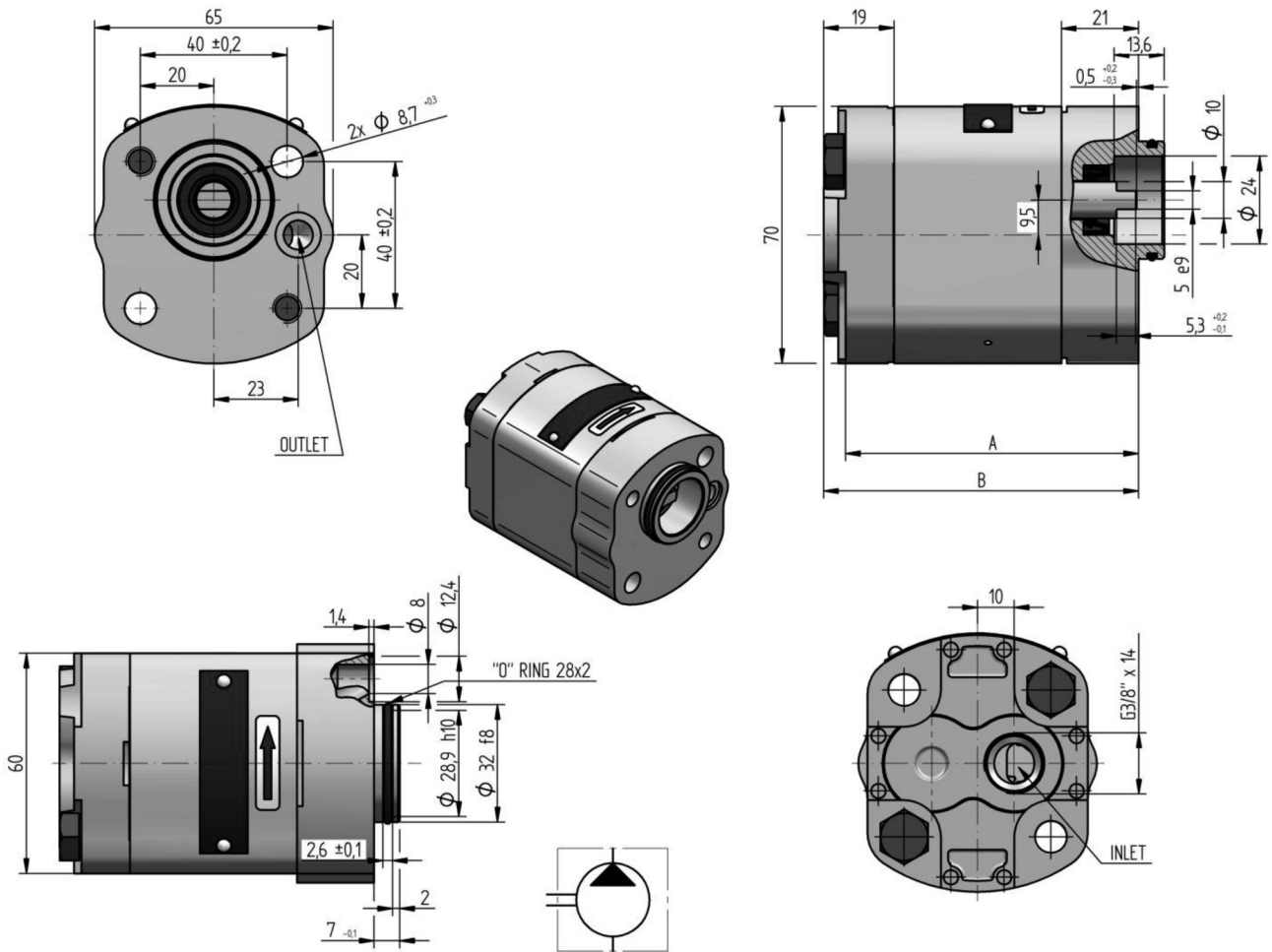

Order key	purch. code	direct. of rot.	displacement [cm ³ /1]	nom. press. [bar]	speed MIN. [min ⁻¹]	speed MAX. [min ⁻¹]	dimension	
							A [mm]	B [mm]
P23-7.9R- A03K03-AG02P01-N	187 9895	R	7.9	160	500	3 000	95.6	101.6
		L						
P23-6.2R- A03K03-AG02P01-N	187 9898	R	6.2	180	500	3 500	89.3	95.3
		L						
P23-5.8R- A03K03-AG02P01-N	187 9894	R	5.8	200	500	3 500	87.8	93.8
		L						
P23-4.8R- A03K03-AG02P01-N	187 9900	R	4.8	230	500	3 800	84.0	90.0
		L						
P23-4.4R- A03K03-AG02P01-N	187 9902	R	4.4	250	500	4 000	82.5	88.5
		L						
P23-3.6R- A03K03-AG02P01-N	187 9901	R	3.6	260	500	4 000	79.6	85.6
		L						
P23-3.3R- A03K03-AG02P01-N	187 9882	R	3.3	280	500	4 000	78.5	84.5
		L						
P23-2.5R- A03K03-AG02P01-N	187 9897	R	2.5	280	500	4 500	75.5	81.5
		L						
P23-2.1R- A03K03-AG02P01-N	187 9896	R	2.1	280	600	4 500	73.9	79.9
		L						
P23-1.6R- A03K03-AG02P01-N	187 9998	R	1.6	280	600	5 000	72.3	78.3
		L						
P23-1.2R- A03K03-AG02P01-N	187 9997	R	1.2	280	600	5 000	70.8	76.8
		L						
P23-0.8R- A03K03-AG02P01-N	187 9996	R	0.8	280	800	5 000	69.3	75.3
		L						

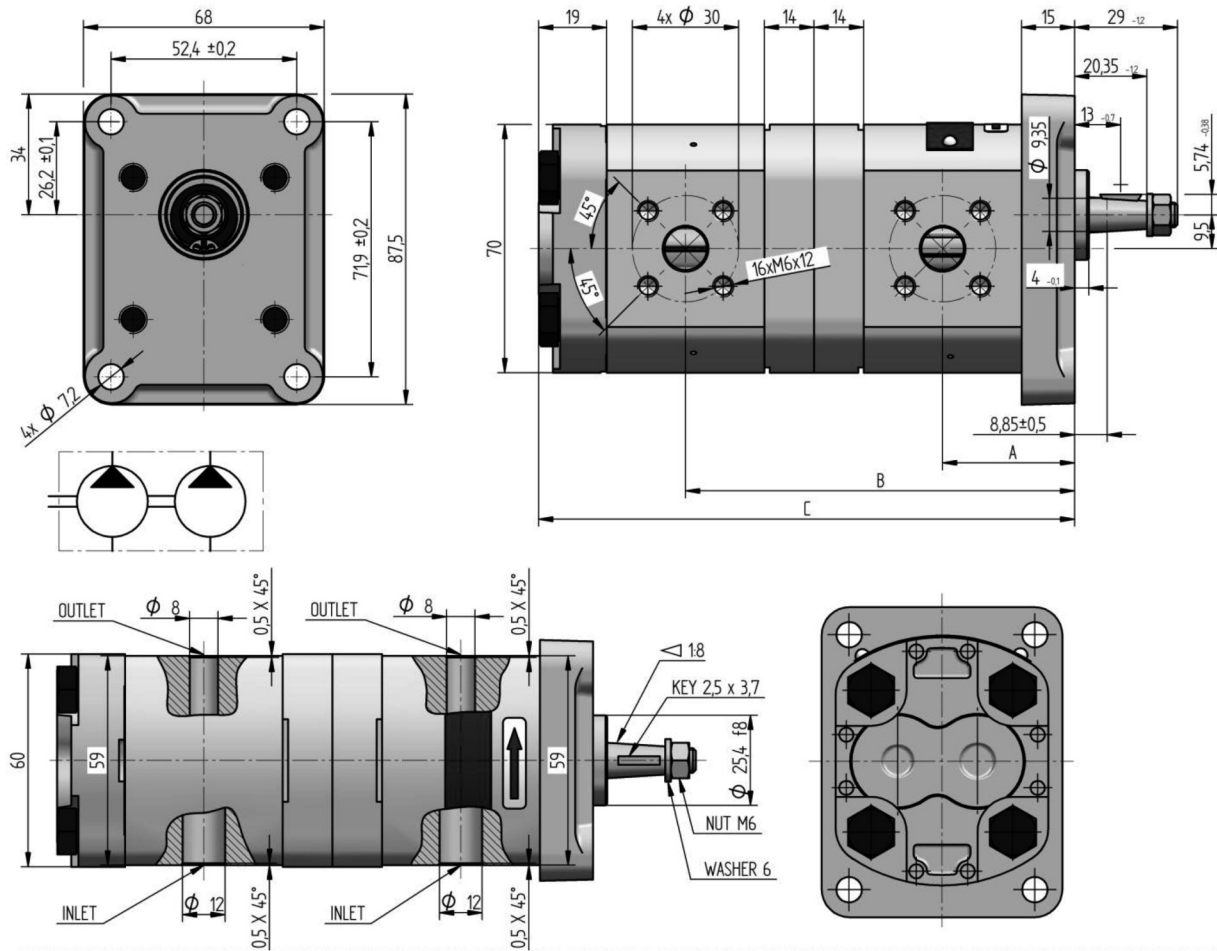

Order key	purch. code	direct. of rot.	displacement [cm ³ /1]	nom. press. [bar]	speed MIN. [min ⁻¹]	speed MAX. [min ⁻¹]	dimension		
							A [mm]	B [mm]	C [mm]
P23-6.2/2.5R-R02C02-SH04H03/H04H03-N		R L	6.2/2.5	180/280	500	3 500	42.6	119.0	158.8
P23-4.8/2.5R-R02C02-SH04H03/H04H03-N	187 9888	R L	4.8/2.5	230/250	500	3 800	40.0	113.7	153.5
P23-3.6/3.6R-R02C02-SH04H03/H04H03-N	187 9866	R L	3.6/3.6	200/260	500	4 000	37.8	111.4	153.2
P23-3.6/2.5R-R02C02-SH04H03/H04H03-N	187 9865	R L	3.6/2.5	260/280	500	4 000	37.8	109.3	149.1
P23-2.5/2.5R-R02C02-SH04H03/H04H03-N		R L	2.5/2.5	280/280	500	4 500	35.7	105.2	145.0
P23-1.2/0.8R-R02C02-SH04H03/H04H03-N		R L	1.2/0.8	280/280	600	5 000	33.4	97.4	134.1

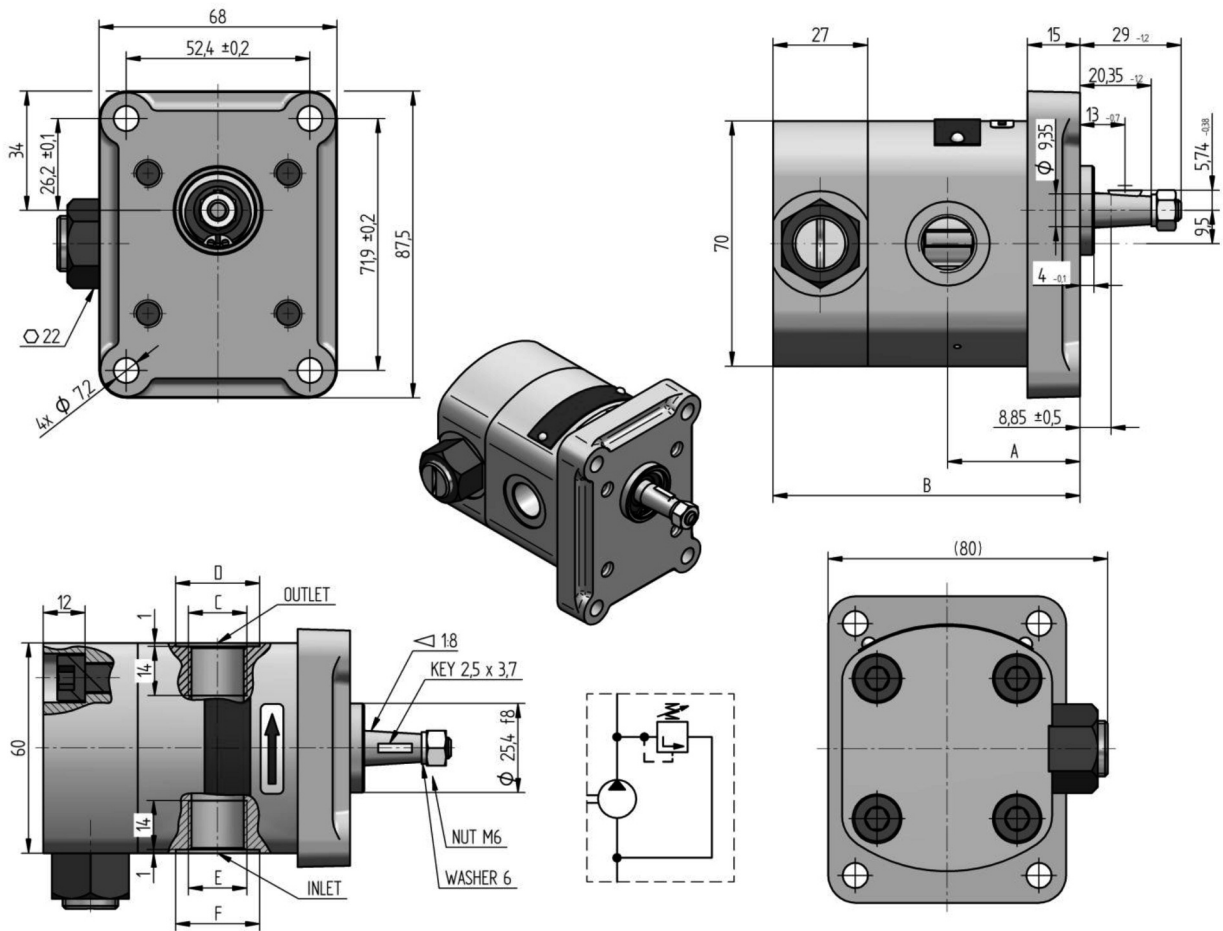

Order key	purch. code	direct. of rot.	displacement [cm ³ /1]	nom. press. [bar]	speed MIN. [min ⁻¹]	speed MAX. [min ⁻¹]	dimension					
							A [mm]	B [mm]	C [mm]	D [mm]	E [mm]	F [mm]
P23-7.9R-R02C02-SG02G02-N.002		R	7.9		500	3 000	45.8	103.6	G 3/8	Ø 24	G 3/8	Ø 24
P23-6.2R-R02C02-SG02G02-N.002		R	6.2		500	3 500	42.6	97.3	G 3/8	Ø 24	G 3/8	Ø 24
P23-5.8R-R02C02-SG02G02-N.002		R	5.8		500	3 500	41.9	95.8	G 3/8	Ø 24	G 3/8	Ø 24
P23-4.8R-R02C02-SG02G02-N.002		R	4.8		500	3 800	40.0	92.0	G 3/8	Ø 24	G 3/8	Ø 24
P23-4.4R-R02C02-SG02G02-N.002		R	4.4		500	4 000	39.2	90.5	G 3/8	Ø 24	G 3/8	Ø 24
P23-3.6R-R02C02-SG02G02-N.002	187 9002	R	3.6	60 ± 5	500	4 000	37.8	87.6	G 3/8	Ø 24	G 3/8	Ø 24
P23-3.3R-R02C02-SG02G02-N.002		R	3.3		500	4 000	37.2	86.5	G 3/8	Ø 24	G 3/8	Ø 24
P23-2.5R-R02C02-SG02G02-N.002		R	2.5		500	4 500	35.7	83.5	G 3/8	Ø 24	G 3/8	Ø 24
P23-2.1R-R02C02-SG02G02-N.002		R	2.1		600	4 500	34.9	81.9	G 3/8	Ø 24	G 3/8	Ø 24
P23-1.6R-R02C02-SG02G02-N.002		R	1.6		600	5 000	34.1	80.3	G 3/8	Ø 24	G 3/8	Ø 24
P23-1.2R-R02C02-SG02G02-N.002		R	1.2		600	5 000	33.4	78.8	G 3/8	Ø 24	G 3/8	Ø 24
P23-0.8R-R02C02-SG02G02-N.002		R	0.8		800	5 000	32.6	77.3	G 3/8	Ø 24	G 3/8	Ø 24

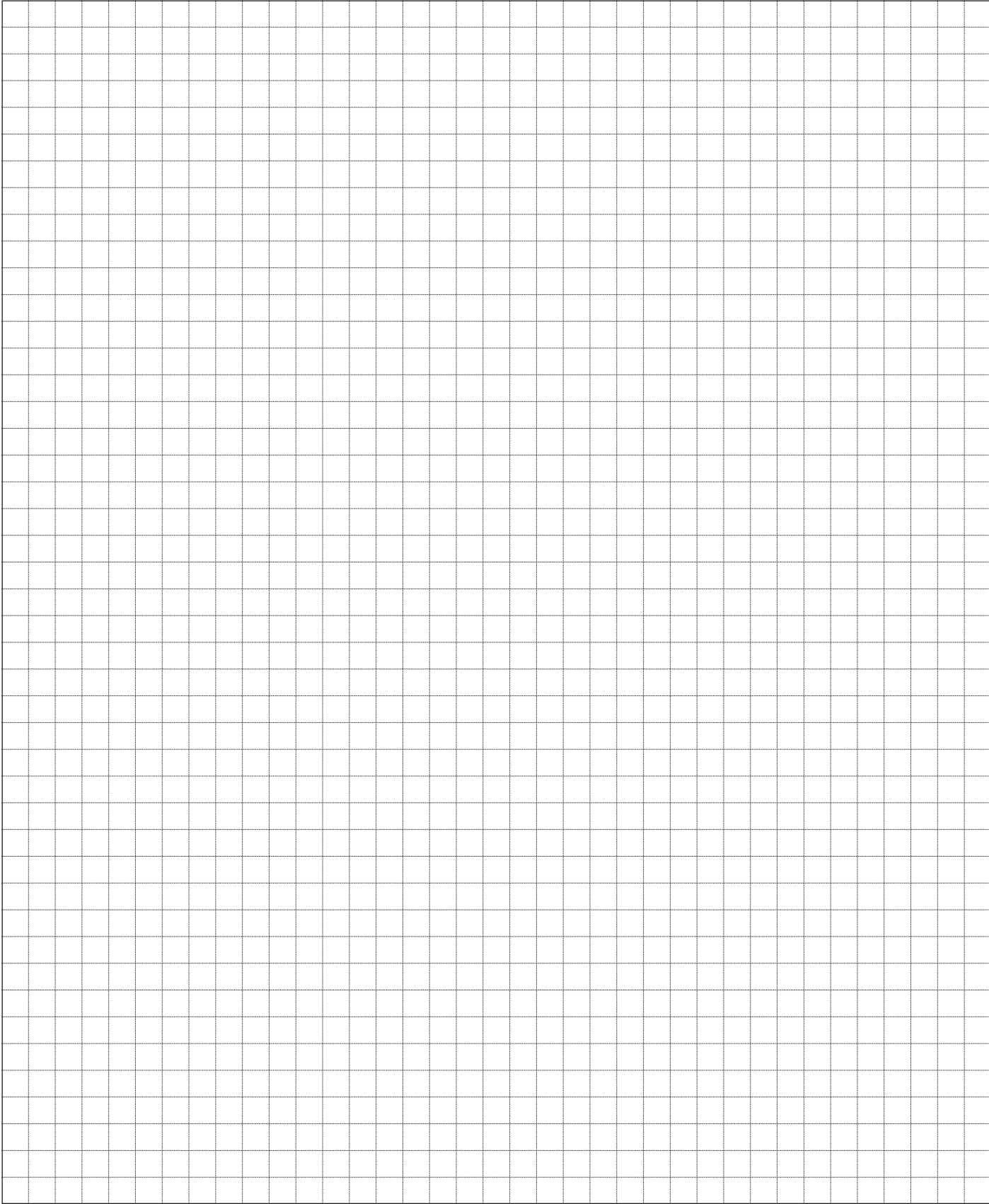

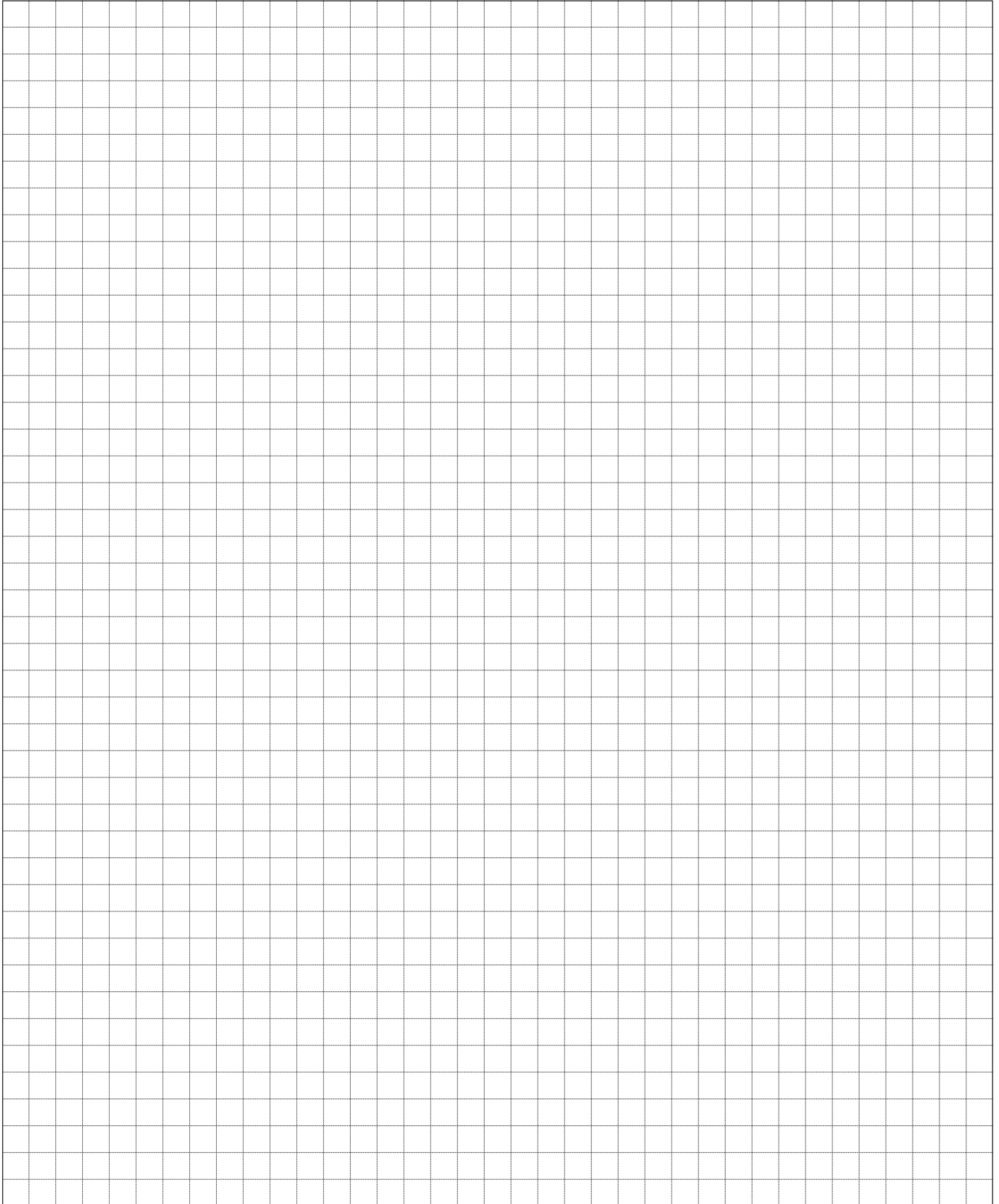

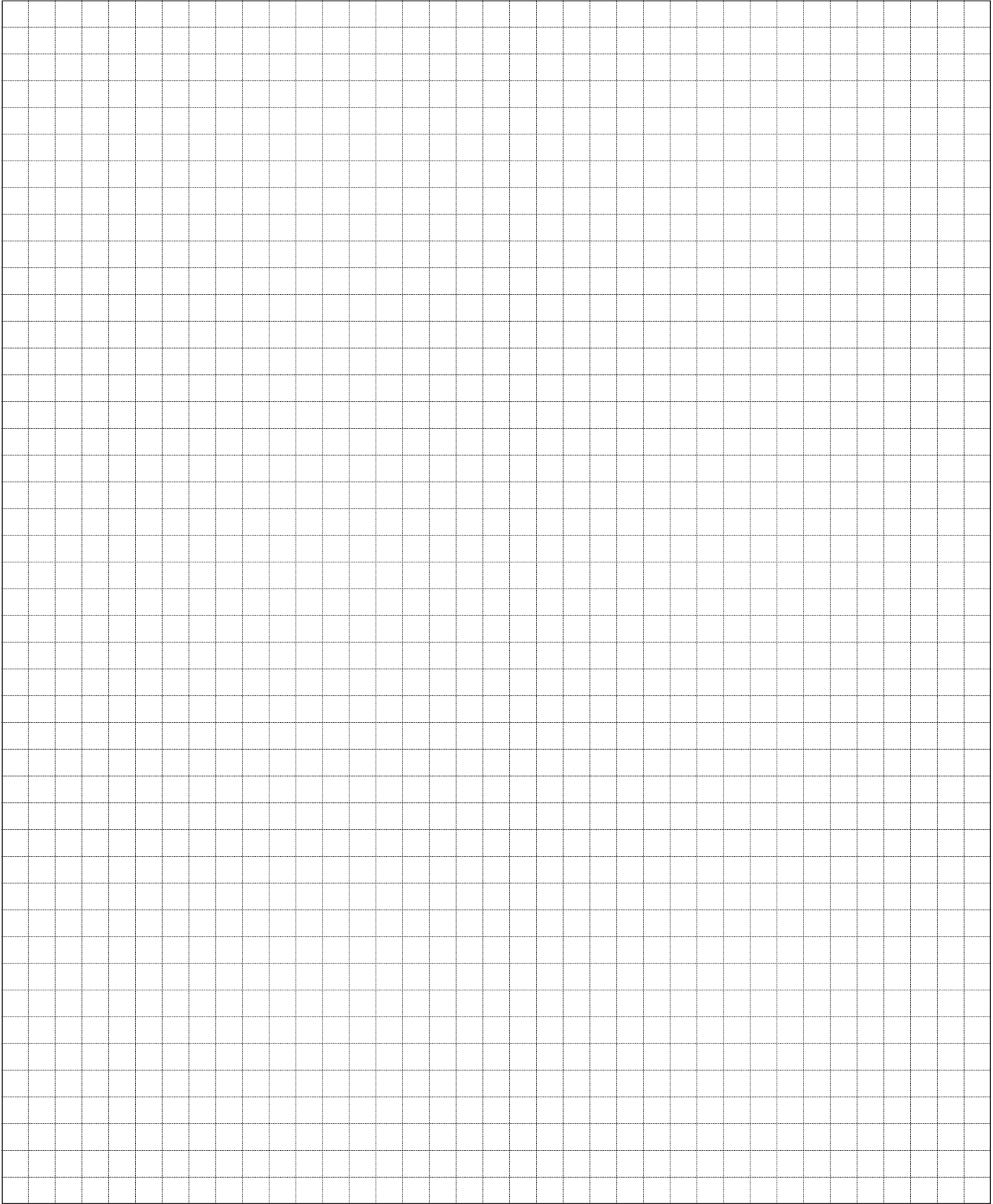

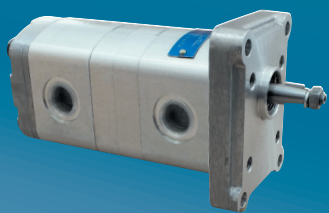
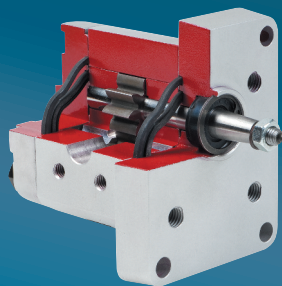
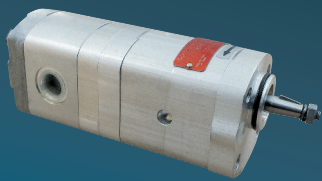

jihostroj
AERO TECHNOLOGY & HYDRAULICS

JIHOSTROJ a.s.
Budějovická 148
CZ 382 32 Velešín
Czech Republic
tel.: +420 380 340 511
fax: +420 380 340 612
e-mail: mailbox@jihostroj.cz
http: //www.jihostroj.com

GPS 48°49'51.748" N 14°27'40.770" E

