

Displacement from 17 to 71 ccm
Pressure up to 300 bar
Speed from 350 to 3200 RPM

GEAR PUMPS
GHD1

TABLE OF CONTENTS

DESCRIPTION.....	2
BASIC PARTS OF PUMP.....	2
PARAMETER TABLE.....	3
FORMULAS USED FOR CALCULATION.....	4
PUMP EFFICIENCIES.....	4
WORKING LIQUID.....	5
PRESSURE LOAD.....	5
OTHER REQUIREMENTS.....	6
DIRECTION OF ROTATION.....	6
REVERSIBLE DESIGN.....	6
GHD1 FLOW RATE AND POWER CURVES.....	7
GHD2 FLOW RATE AND POWER CURVES.....	9
ORDER KEY – SINGLE VERSION.....	10
ORDER KEY – MULTIPLE VERSION.....	11
COMBINATION OF FLANGES AND SHAFTS.....	12
FLANGE DESIGN.....	13
DRIVE SHAFTS.....	14
LIQUID INLET AND OUTLET CONNECTION.....	16
CATALOGUE SHEETS OF GHD1 SERIES BASIC DESIGN.....	18
NOTE.....	22

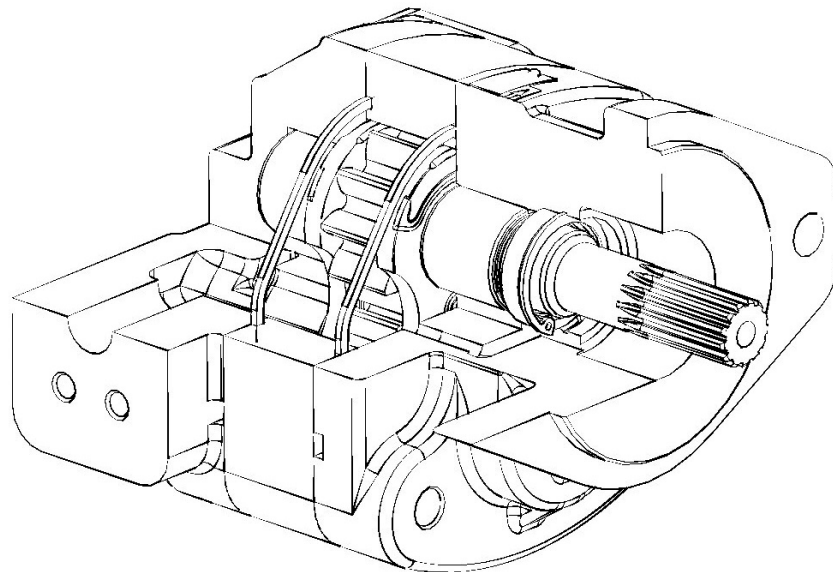

DESCRIPTION

- GHD1 Series Pumps with external gearing for its massive cast iron construction are designed for the toughest operations in agricultural and construction equipment. The series covers a wide range displacement from 17 to 71 cm³.
- These pumps are characterized by a three-part, all-cast-iron structure: flange – body – cover. Bushings supporting gear studs are pressed into the flange and the cover. Gear wheels, which are optimised to achieve a low noise level, are made of ultra high-strength steel. Liquid inlet and outlet are located in the cover (thus, the body is not weakened by them and a higher pressure load is possible) from sides or axially in the cover. The axial power balancing is performed using sliding aluminium alloy pressure plates in which a shape sealing of balancing surface is located in grooves. The flange dimensions enable a design with a pre-shaft with bearings for a higher radial or axial load of the drive.
- The GHD1 pumps are produced in various designs of drives, clamping flanges as well as liquid inlets and outlets. These pumps comply with the standards ISO, SAE, UNI and other world-recognised standards, they can be delivered in one-way single-section as well as multiple-section designs. They can also be delivered in a reversible design, with external or internal drainage.

BASIC PARTS OF PUMP

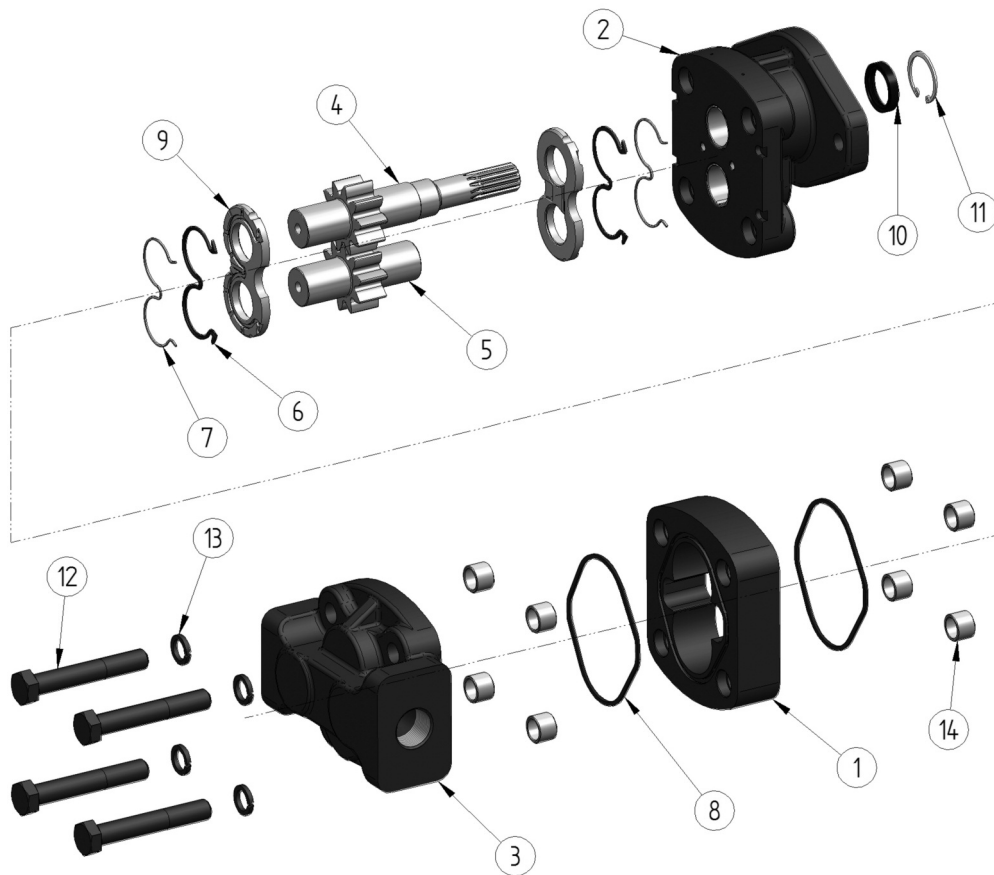

1. Body
2. Flange
3. Cover
4. Driving gear
5. Driven gear
6. Balancing sealing
7. Sealing protective plate
8. Peripheral sealing
9. Pressure plates
10. Shaft seal
11. Safety ring
12. Connection bolts
13. Spring washer
14. Cantering tube

PARAMETER TABLE

Nominal Size Parameters		Sym.	Unit.	GHD1 17	GHD1 27	GHD1 34	GHD1 43
Actual displacement		V_g	[cm ³]	17.39	27.53	34.05	43.47
Rotation speed	nominal	n_n	[min ⁻¹]	1500	1500	1500	1500
	minimum	n_{min}	[min ⁻¹]	400	400	400	400
	maximum	n_{max}	[min ⁻¹]	3200	3200	3000	2800
Pressure at inlet*	minimum	p_{1min}	[bar]	-0.3	-0.3	-0.3	-0.3
	maximum	p_{1max}	[bar]	0.5	0.5	0.5	0.5
Pressure at outlet**	max. continuous	p_{2n}	[bar]	300	300	300	280
	maximum	p_{2max}	[bar]	320	320	320	300
	peak	p_3	[bar]	330	330	330	310
Nominal flow rate (min.) at n_n and p_{2n}		Q_n	[dm ³ .min ⁻¹]	23.5	38.0	48.0	61.3
Maximum flow rate at n_{max} a p_{2max}		Q_{max}	[dm ³ .min ⁻¹]	54.5	86.3	100.1	119.3
Nominal input power (max.) at n_n and p_{2n}		P_n	[kW]	16.1	24.9	30.2	36.0
Maximum input power at n_{max} a p_{2max}		P_{max}	[kW]	33.6	53.3	61.8	69.0
Weight		m	[kg]	-	-	-	-

Nominal Size Parameters		Sym.	Unit.	GHD1 51	GHD1 56	GHD1 61	GHD1 71
Actual displacement		V_g	[cm ³]	51.44	55.79	61.59	71.01
Rotation speed	nominal	n_n	[min ⁻¹]	1500	1500	1500	1500
	minimum	n_{min}	[min ⁻¹]	350	350	350	350
	maximum	n_{max}	[min ⁻¹]	2600	2400	2200	1800
Pressure at inlet*	minimum	p_{1min}	[bar]	-0.3	-0.3	-0.3	-0.3
	maximum	p_{1max}	[bar]	0.5	0.5	0.5	0.5
Pressure at outlet**	max. continuous	p_{2n}	[bar]	260	250	230	210
	maximum	p_{2max}	[bar]	280	270	250	230
	peak	p_3	[bar]	290	280	260	240
Nominal flow rate (min.) at n_n and p_{2n}		Q_n	[dm ³ .min ⁻¹]	72.5	78.7	86.8	100.1
Maximum flow rate at n_{max} a p_{2max}		Q_{max}	[dm ³ .min ⁻¹]	131.1	131.2	132.8	125.3
Nominal input power (max.) at n_n and p_{2n}		P_n	[kW]	39.5	41.2	41.9	44.1
Maximum input power at n_{max} a p_{2max}		P_{max}	[kW]	70.8	68.3	64.0	55.6
Weight		m	[kg]	-	-	-	-

* Inlet pressure in the reversible design can be up to $p_1 = p_{2n} - 70$ bar max. External drainage must be used in case of the reversible design.

** Outlet pressure in the reversible design is **10% lower** than shown in the table (depending on operating conditions - it is necessary to consult with the manufacturer).

FORMULAS USED FOR CALCULATION

Flow rate
 Q

$$Q = \frac{V_g \cdot n}{1000} \cdot \eta_v \quad [\text{dm}^3 \cdot \text{min}^{-1}]$$

V_g [cm³] pump displacement
 n [min⁻¹] rotation speed
 η_v [-] volumetric efficiency

Displacement
 V_g

$$V_g = \frac{Q \cdot 1000}{n \cdot \eta_v} \quad [\text{cm}^3]$$

Torque
 M_k

$$M_k = \frac{V_g \cdot p}{20 \cdot \pi \cdot \eta_m} \quad [\text{Nm}]$$

p [bar] required pressure at outlet
 η_m [-] mechanical efficiency

Input power
 P

$$P = \frac{V_g \cdot n \cdot p}{600 \cdot 1000 \cdot \eta_t} \quad [\text{kW}]$$

η_t [-] total efficiency

PUMP EFFICIENCIES

Volumetric efficiency
 η_v

It determines the amount of flow losses. Its value is $\eta_v = 0,92 \div 0,98$ (depending on rotation speed, viscosity of working liquid and outlet pressure). It can be expressed as follows:

$$\eta_v = \frac{Q_{act.}}{Q_{theor}} \quad [-]$$

$Q_{act.}$ [dm³ · min⁻¹] actual flow rate
 Q_{theor} [dm³ · min⁻¹] theoretical flow rate

Mechanical efficiency
 η_m

It determines mechanical losses. Its value is about $\eta_m = 0,85$.
It can be expressed as follows:

$$\eta_m = \frac{M_{theor}}{M_{act.}} \quad [-]$$

$M_{act.}$ [Nm] actual torque
 M_{theor} [Nm] theoretical torque

Total efficiency
 η_t

It is defined as product of η_n and η_m and determines difference between theoretical and actual required input power:

$$\eta_t = \eta_v \cdot \eta_m = \frac{P_{theor}}{P_{act.}} \quad [-]$$

$P_{act.}$ [kW] actual input power
 P_{theor} [kW] theoretical input power

WORKING LIQUID

- Mineral oils for hydraulic drives
- Hydraulic liquids based on plant oils suitable for hydraulic drives

Liquid temperature

- $t = -20 \div +80$ [°C]
when used with FKM (Viton) seal up to 120 [°C]

Cinematic viscosity

- Recommended (during continuous operation): $\nu = 20 \div 80 \cdot 10^{-6} [\text{m}^2 \cdot \text{s}^{-1}]$
- Maximum (cold starting, at viscosity >1000 , operating pressure <10 bar is permissible, speed $<1500 \cdot \text{min}^{-1}$): $\nu = 1200 \cdot 10^{-6} [\text{m}^2 \cdot \text{s}^{-1}]$
- Minimum (operating mode at $10 \cdot 10^{-6}$ up $20 \cdot 10^{-6}$ should be consulted with manufacturer): $\nu = 10 \cdot 10^{-6} [\text{m}^2 \cdot \text{s}^{-1}]$

Filtration coefficient β_α

$\beta_{25\ 75} \geq$ (for pressure $p_2 < 200$ bar)
 $\beta_{10\ 75} \geq$ (for pressure $p_2 > 200$ bar)

Liquid contamination class according to ISO 4406

21/18/15 (for pressure $p_2 < 200$ bar)
20/17/14 (for pressure $p_2 > 200$ bar)

Liquid contamination class according to NAS 1638

10 (for pressure $p_2 < 200$ bar)
8 (for pressure $p_2 > 200$ bar)

PRESSURE LOAD

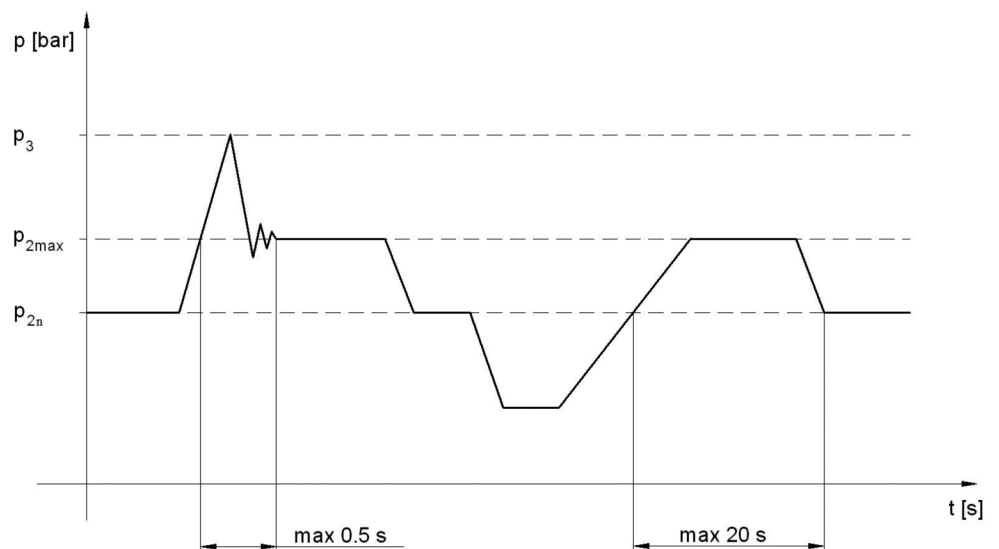

- p_{2n} **max. contin. pressure** Max. working pressure, at which the pump can be operated without time limitation.
- p_{2max} **max. pressure** Maximum pressure permissible for a short time, max. 20s.
- p_3 **peak pressure** Short-time pressure (fractions of a second) arising in case of a sudden change of the operating mode; any excess of this pressure during operation is impermissible.

OTHER REQUIREMENTS

- A driving device must not generate an axial or a radial load of the pump shaft, unless this is exclusively permitted for the pump with a front-end bearing.
- All the matters affecting technical parameters and properties of the pump are given in respective operating manuals, technical specifications and test specifications of the manufacturer.

DIRECTION OF ROTATION

- Determine direction of rotation by looking at the drive shaft. The pump can only be used in the specified direction of rotation.

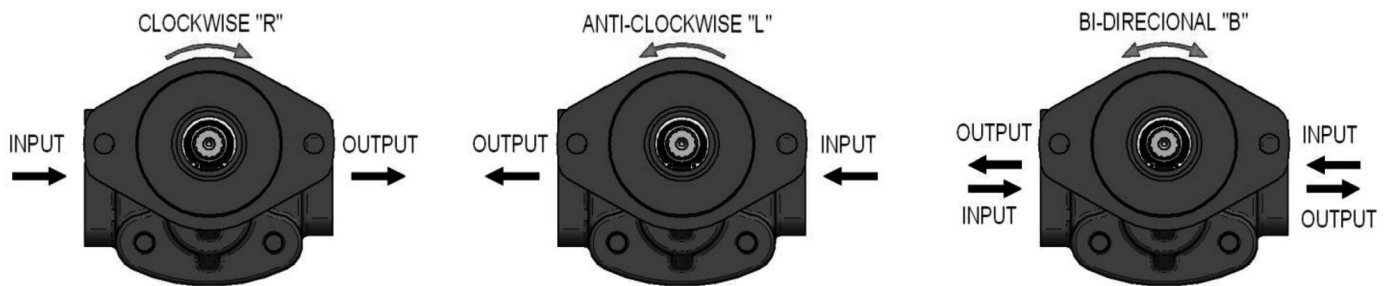

REVERSIBLE DESIGN

- The pumps with the possibility of bidirectional rotation have a different internal arrangement requiring drainage. Two types of drain are used - internal and external. The internal drainage is always interconnected with the outlet by means of valves. The external drainage is solved by an orifice located in the cover opposite the driven gear.

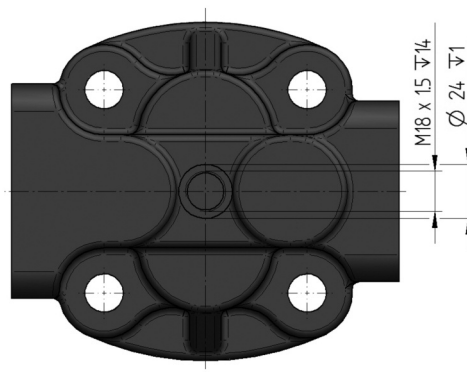

GHD1 FLOW RATE AND POWER CURVES

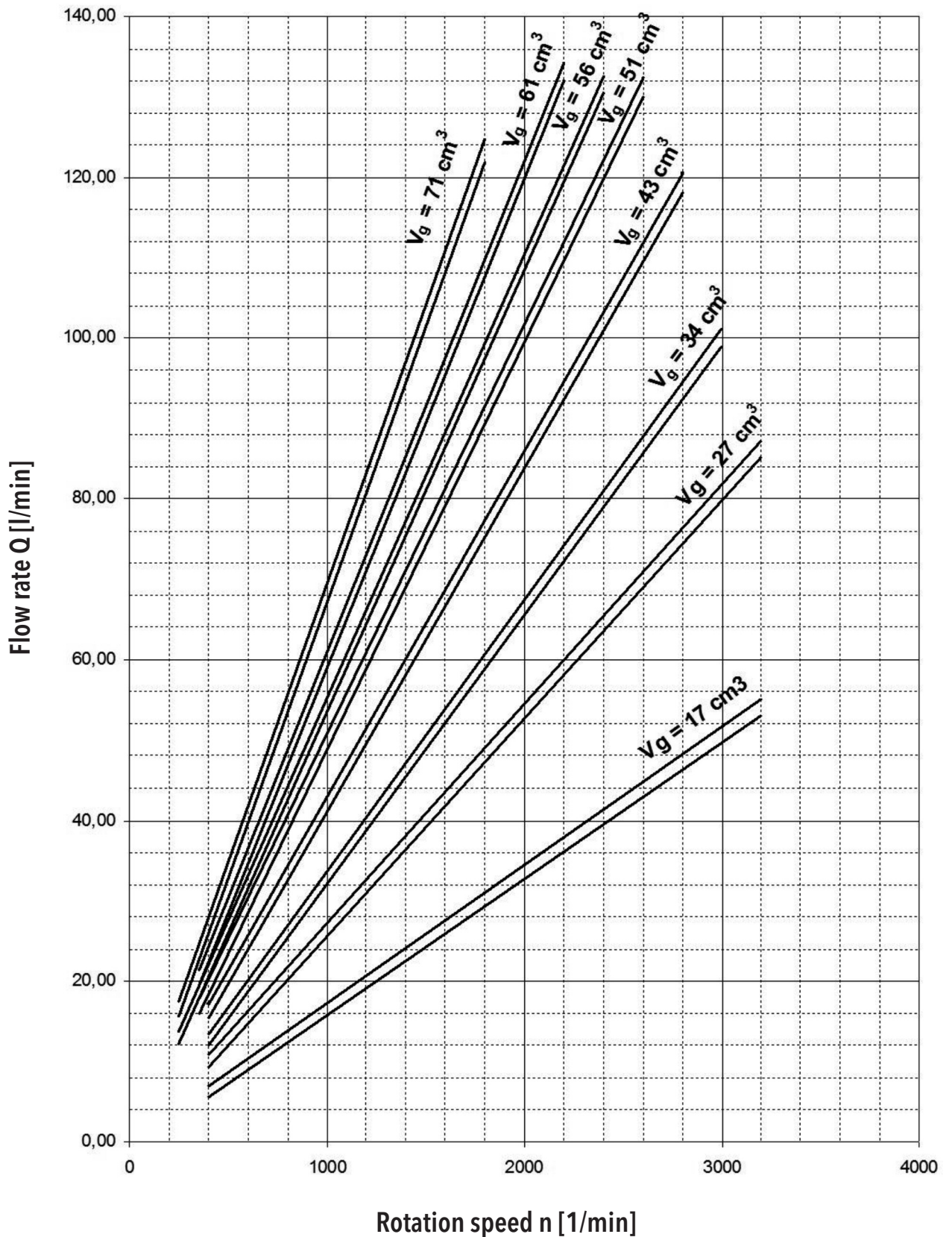

Above curves apply to ISO Vg 46 oil at temperature $t = 45^\circ\text{C}$.

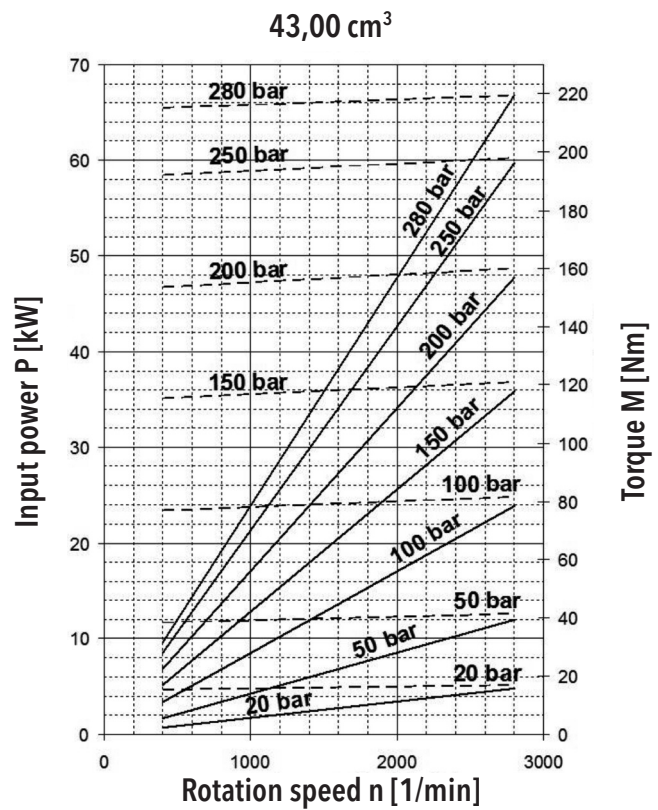
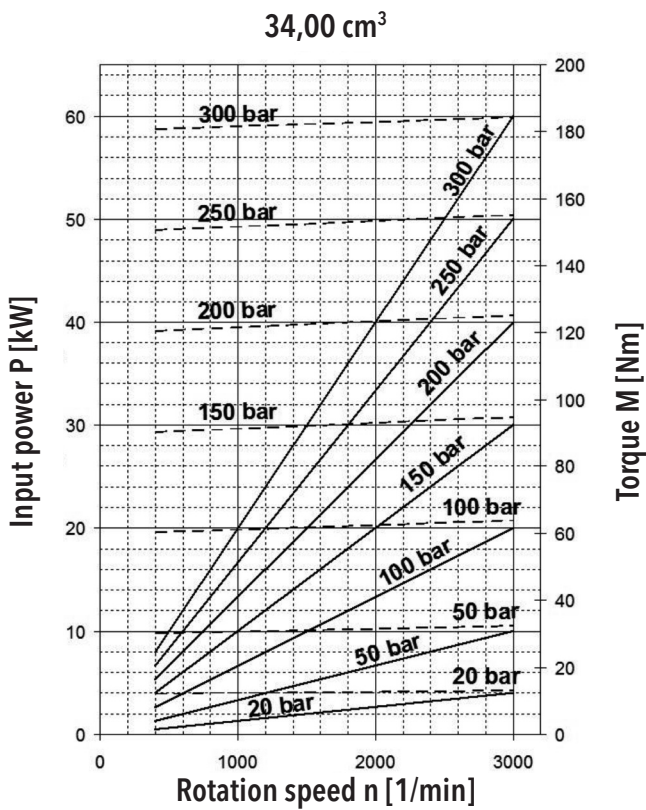
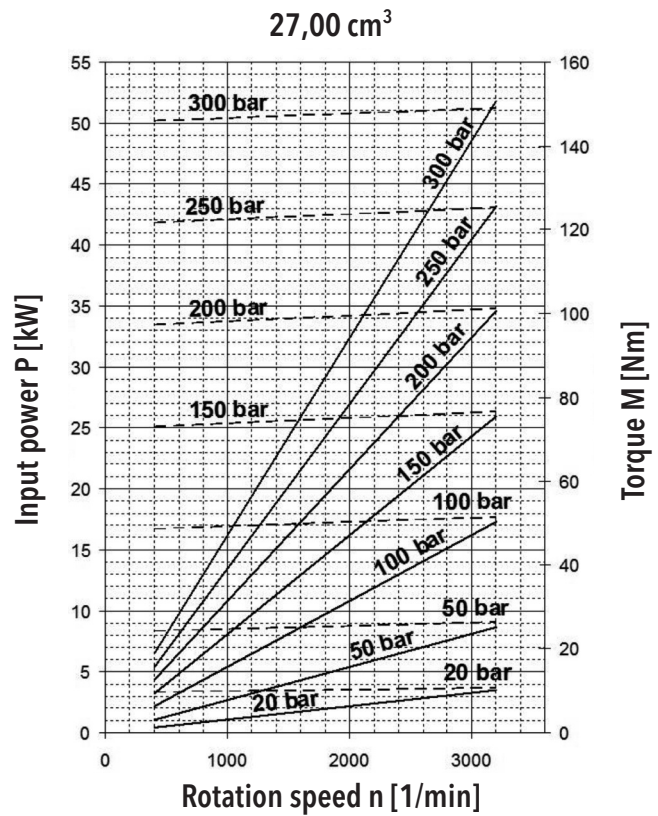
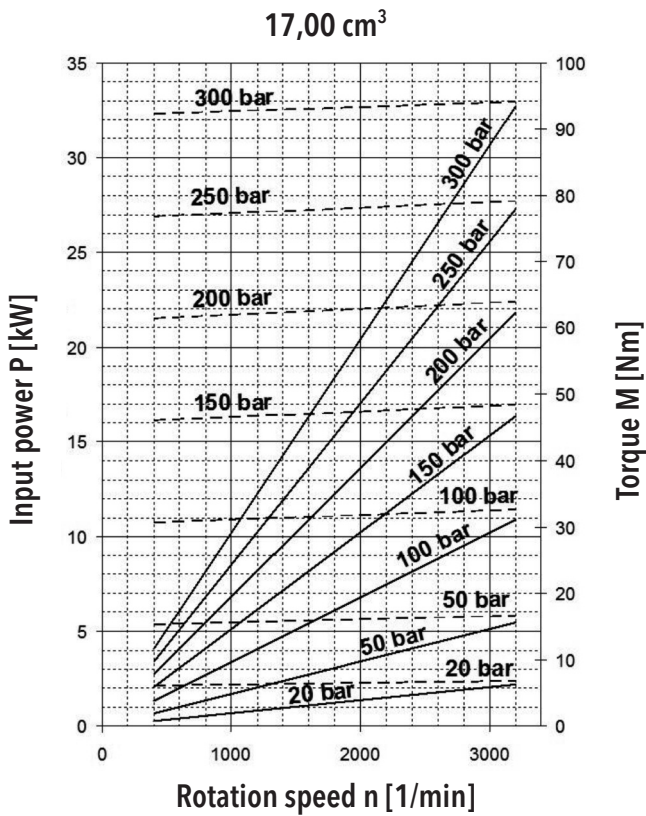

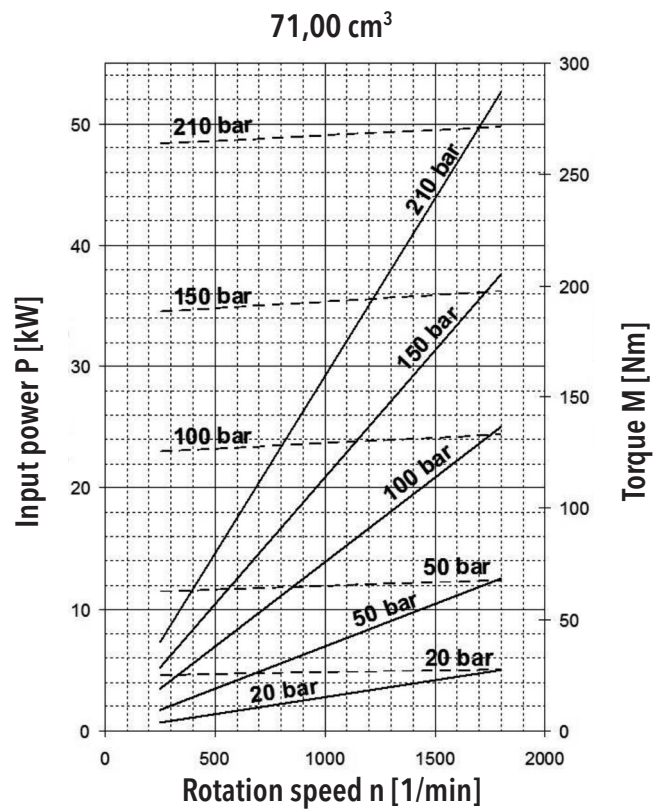
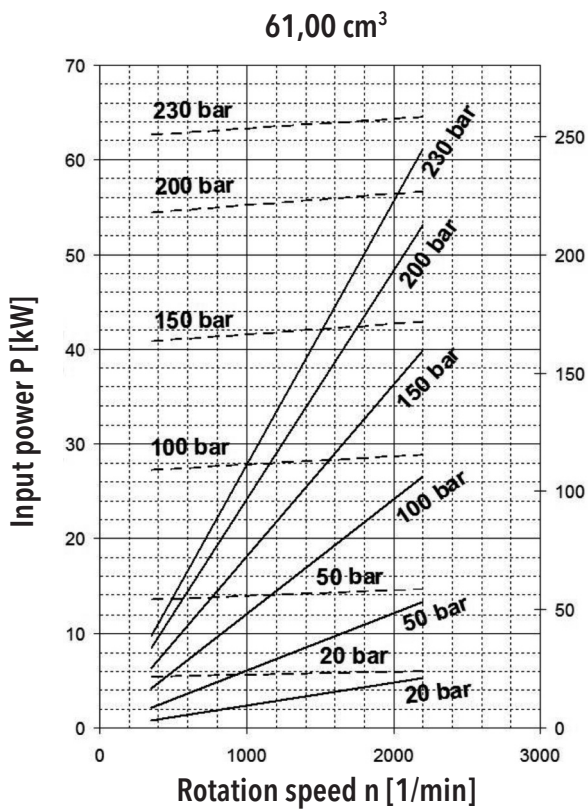
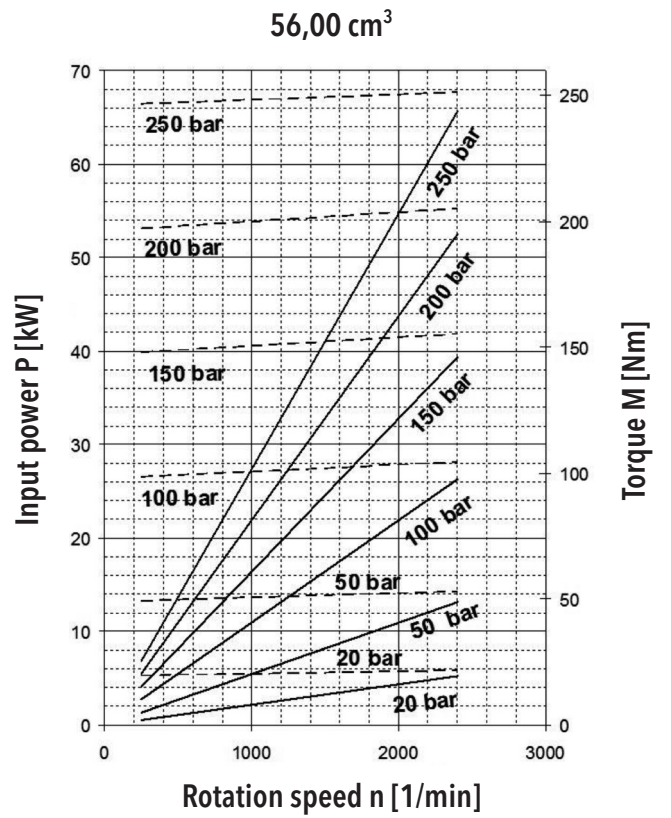
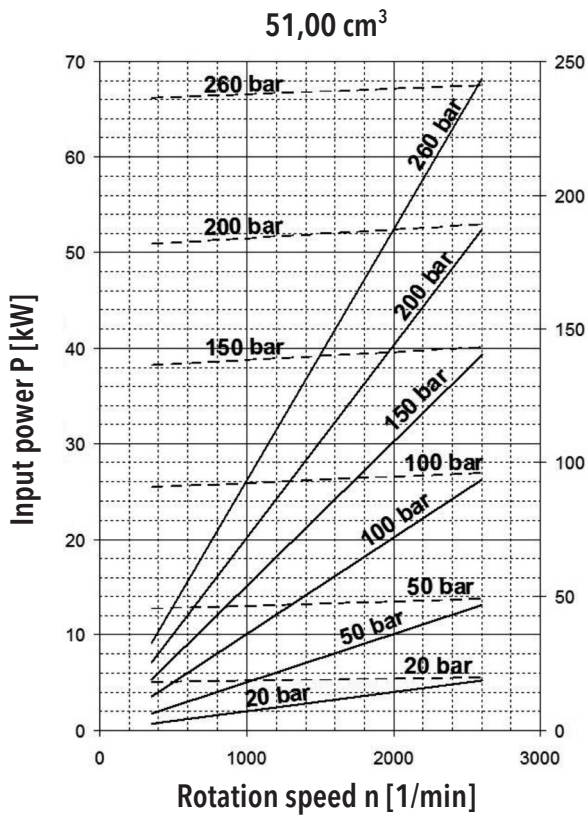

ORDER KEY - SINGLE VERSION

GHD1 - 34 R - S02 D13 - S G05 G04 - N . 001

Code	Type
GHD1	GHD1 Series Gear Pump

Code	Displacement [cm ³]
17	17,39
27	27,53
34	34,05
43	43,47
51	51,44
71	71,01
XX	Other displacements on request

Code	Direction of rotation
R	Clockwise
L	Anti-clockwise
B	Bi-directional

Code	Location of inlets and outlets
S	Side (in the body)
R	Axial (in the cover)
C	Combination

Code	Seal material
N	NBR
V	FKM (VITON)
H	HNBR

Code	Special arrangements
-	No special arrangements
001	With front end bearing
004	Without shaft seal
012	Rear and side input and output

Code	Flange design
R14	Rectangle flange, centre ring $\varnothing 95$, Spacing screw 140 x 190
R15	Squared flange, centre ring $\varnothing 90$, Spacing screw 155 x 155
S02	SAE A 2 apertures
S03	SAE B 2 apertures
S04	SAE C 2 apertures
S06	SAE C 2 + 4 apertures
I02	ISO, centre ring $\varnothing 50$
F03	Squared flange, centre ring $\varnothing 125$, Spacing screw $\varnothing 160$
Z	Special desing

Code	Drive shaft desing
D13	Spline SAE B 13T
D14	Spline SAE C 14T
D15	Spline SAE BB 15T
D18	Spline DIN 5462 A8 x 32 x 36 x 6
D19	Spline ČSN 28 x 1,5
D25	Spline ČSN 014942 D-6 x 28 x 34e9 x 7
D26	Spline ČSN 38 x 1,5
D27	Spline DIN 5480 WA 35 x 2 x 16 x 9g
V17	Cylindric SAE B, $\varnothing 22,22$ Key 6,4 x 6,4 x 25,4
V18	Cylindric SAE BB, $\varnothing 25,4$ Key 6,4 x 6,4 x 31,8
V19	Cylindric SAE C, $\varnothing 31,7$ Key 7,9 x 7,9 x 31,8
Z	Special desing

Code	Liquid inlet and outlet connection shape
M09	Thread M 27x2
M12	Thread M 33x2
M15	Thread M 48x2
G04	Thread BSP G 3/4"
G05	Thread BSP G1"
G06	Thread BSP G1 1/4"
G07	Thread BSP G1 1/2"
G09	Thread BSP G2"
U05	Thread 1-1/16-12 UN
U07	Thread 1-5/16-12 UN
U08	Thread 1-5/8-12 UN
U09	Thread 1-7/8-12 UN
H09	Fitting $\varnothing 18; 4xM8; \varnothing 55$
H10	Fitting $\varnothing 25; 4xM8; \varnothing 55$
A02	Fitting SAE (SSS) 3/4"
A03	Fitting SAE (SSS) 1"
A04	Fitting SAE (SSS) 1" 1/4
A05	Fitting SAE (SSS) 1" 1/2
A06	Fitting SAE (SSS) 2"
E02	Fitting SAE (SSM) 3/4"
E03	Fitting SAE (SSM) 1"
E04	Fitting SAE (SSM) 1" 1/4
E05	Fitting SAE (SSM) 1" 1/2
E06	Fitting SAE (SSM) 2"
K03	Fitting $\varnothing 18; 4xM8 / \varnothing 40$
K04	Fitting $\varnothing 26; 4xM10 / \varnothing 51$
K05	Fitting $\varnothing 18; 4xM8 / \varnothing 55$
K06	Fitting $\varnothing 25; 4xM8 / \varnothing 55$
S04	Fitting $\varnothing 46; 4xM12 - 78x78$
S05	Fitting $\varnothing 22; 4xM10 - 48x48$
S06	Fitting $\varnothing 30; 4xM10 - 48x48$
Z	Special desing

An example of designation for the GHD1 anti-clockwise pump with displacement of 27 cm³, SAE B flange, SAE B spline, BSP axial inlet and outlet and standard NBR seal without special arrangements: **GHD1-27L-S03D13-RG05G04-N**









ORDER KEY - MULTIPLE VERSION



GHD1 - 34 / 17 / 17 R - S02 D13 - S G05 G04 / G05 G04 / G05 G04 - N . 001

Code	Type
GHD1	GHD1 Series Gear Pump

Code	Displacement [cm ³]
17	17,39
27	27,53
34	34,05
43	43,47
51	51,44
71	71,01
XX	Other displacements on request











Code	Direction of rotation
R	Clockwise
L	Anti-clockwise
B	Bi-directional



















Code	Flange design
R14	 Rectangle flange, centre ring Ø95, Spacing screw 140 x 190
R15	 Squared flange, centre ring Ø90, Spacing screw 155 x 155
S02	 SAE A 2 apertures
S03	 SAE B 2 apertures
S04	 SAE C 2 apertures
S06	 SAE C 2 + 4 apertures
I02	 ISO, centre ring Ø50
F03	 Squared flange, centre ring Ø125, Spacing screw Ø160
Z	Special desing

Code	Location of inlets and outlets	
S		Side (in the body)
C		Combination

Code	Special arrangements
-	No special arrangements
001	With front end bearing
004	Without shaft seal
012	Rear and side input and output

Code	Seal material
N	NBR
V	FKM (VITON)
H	HNBR

Code	Drive shaft desing	
D13		Spline SAE B 13T
D14		Spline SAE C 14T
D15		Spline SAE BB 15T
D18		Spline DIN 5462 A8 x 32 x 36 x 6
D19		Spline ČSN 28 x 1,5
D25		Spline ČSN 014942 D-6 x 28 x 34e9 x 7
D26		Spline ČSN 38 x 1,5
D27		Spline DIN 5480 WA 35 x 2 x 16 x 9g
V17		Cylindric SAE B, Ø22,22 Key 6,4 x 6,4 x 25,4
V18		Cylindric SAE BB, Ø25,4 Key 6,4 x 6,4 x 31,8
V19		Cylindric SAE C, Ø31,7 Key 7,9 x 7,9 x 31,8
Z	Special desing	

Code	Liquid inlet and outlet connection shape	
M09		Thread M 27x2
M12		Thread M 33x2
M15		Thread M 48x2
G04		Thread BSP G 3/4"
G05		Thread BSP G1"
G06		Thread BSP G1 1/4"
G07		Thread BSP G1 1/2"
G09		Thread BSP G2"
U05		Thread 1-1/16-12 UN
U07		Thread 1-5/16-12 UN
U08		Thread 1-5/8-12 UN
U09		Thread 1-7/8-12 UN
H09		Fitting Ø18;4xM8;Ø55
H10		Fitting Ø25;4xM8;Ø55
A02		Fitting SAE (SSS) 3/4"
A03		Fitting SAE (SSS) 1"
A04		Fitting SAE (SSS) 1 1/4"
A05		Fitting SAE (SSS) 1 1/2"
A06		Fitting SAE (SSS) 2"
E02		Fitting SAE (SSM) 3/4"
E03		Fitting SAE (SSM) 1"
E04		Fitting SAE (SSM) 1 1/4"
E05		Fitting SAE (SSM) 1 1/2"
E06		Fitting SAE (SSM) 2"
K03		Fitting Ø18;4xM8 / Ø40
K04		Fitting Ø26;4xM10/Ø51
K05		Fitting Ø18;4xM8 / Ø55
K06		Fitting Ø25;4xM8 / Ø55
S04		Fitting Ø46;4xM12 - 78x78
S05		Fitting Ø22;4xM10 - 48x48
S06		Fitting Ø30;4xM10 - 48x48
N		Without inlet/outlet
Z		Special desing

An example of designation for the GHD1 three-section clockwise pump with displacements of 34, 27 and 17 cm³, SAE B flange, SAE BB spline, BSP thread one common inlet and three outlets and FKM seal without special arrangements: **GHD1-34/27/17R-S03D15-SNG04/G06G04/NG04-V**

Note: In case of combination inlets, with the code „C” is respected following sequence of inlets and outlets:

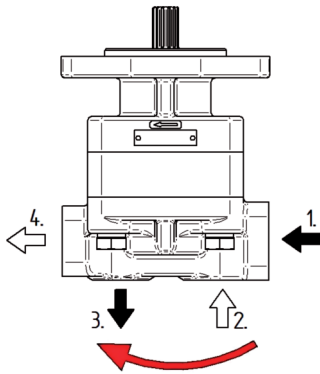

For clockwise and reverse gear pump,
in direction clockwise

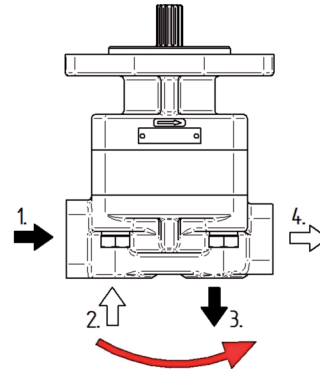

For anti-clockwise gear pump,
in direction anti-clockwise

For. ex....: GHD1-43B-S03D13-CG05 G05 G04 G04 -N
1. 2. 3. 4.

COMBINATIONS OF FLANGES AND SHAFTS

		FLANGE DESIGN									
		R14	R15	S02	S03	S04	S06	I02	F03		
DRIVE SHAFT	D13				●	●					
	D14						●	●			
	D15				○	●	○	○			
	D18								●		
	D19		●								
	D25			●							
	D26		●								
	D27										●
	V17				●	●					
	V18				○	●	○	○			
	V19						●	●			

FLANGES DESIGN

R14:

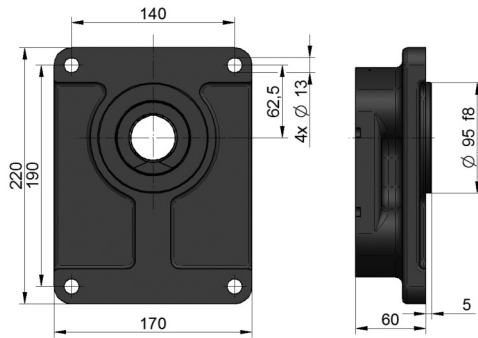

R15:

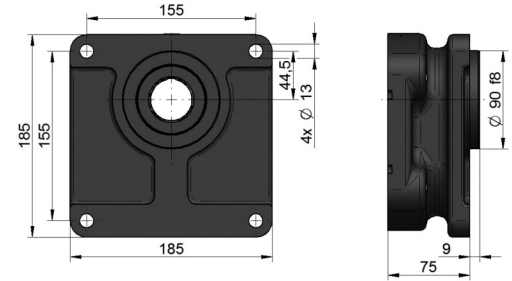

S02:

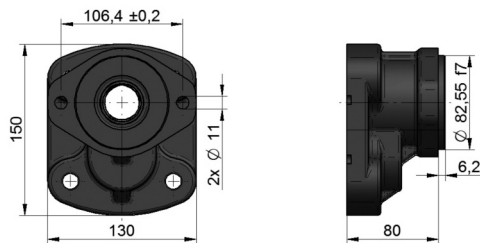

S03:

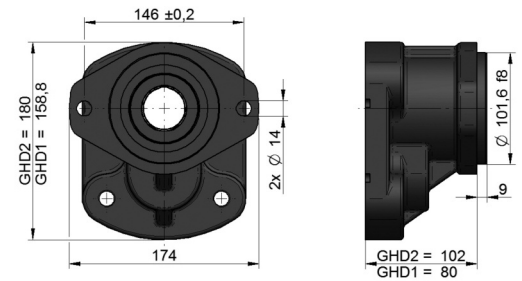

S04:

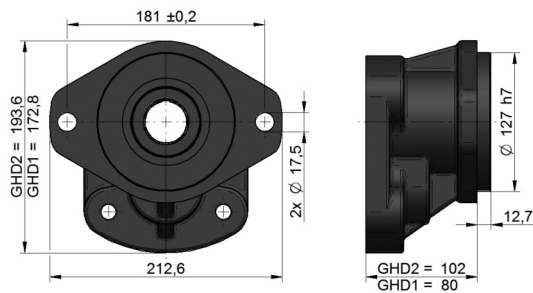

S06:

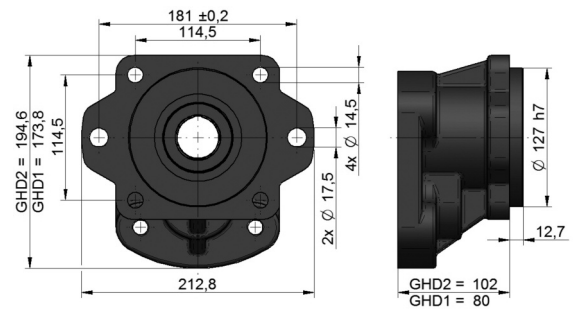

I01:

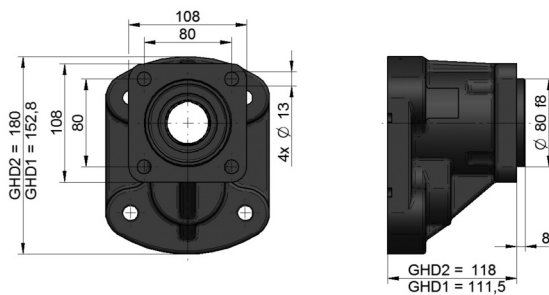

F03:

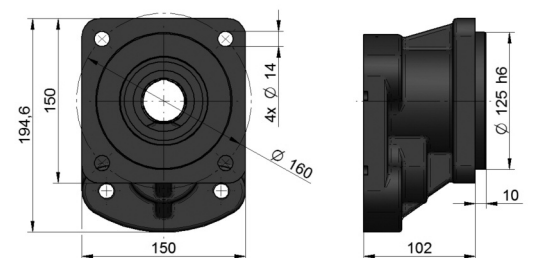

DRIVE SHAFTS

D13:

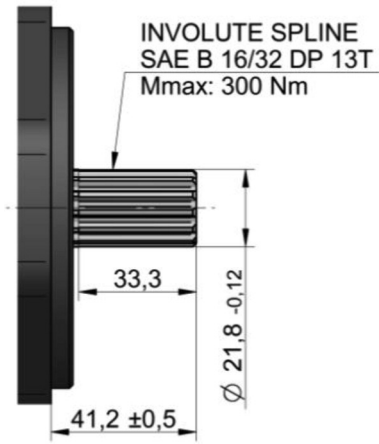

D14:

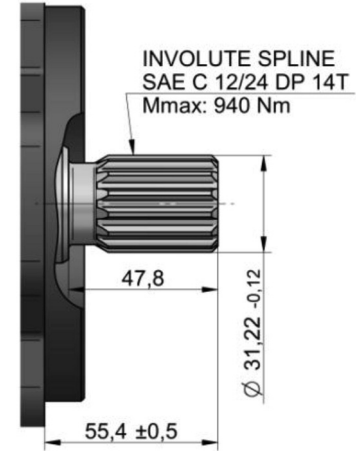

D15:

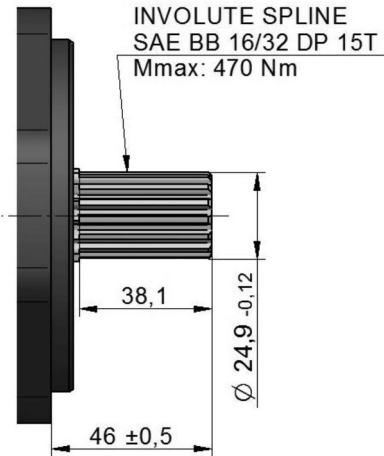

D18:

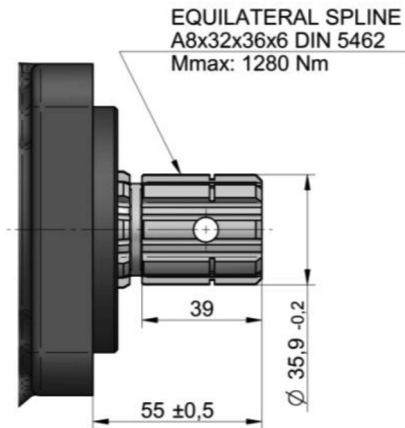

D19:

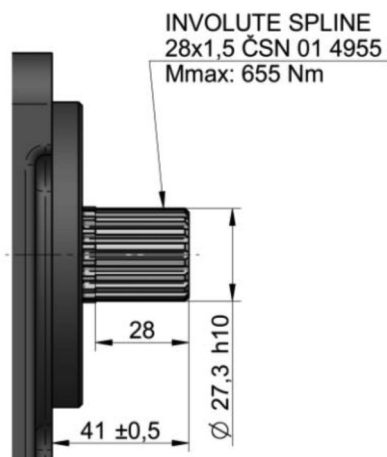

D25:

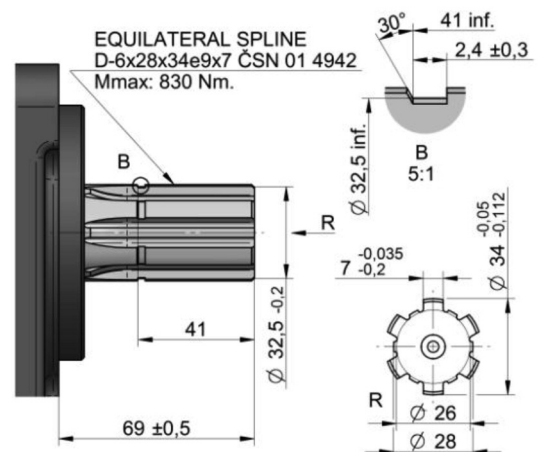

D26:

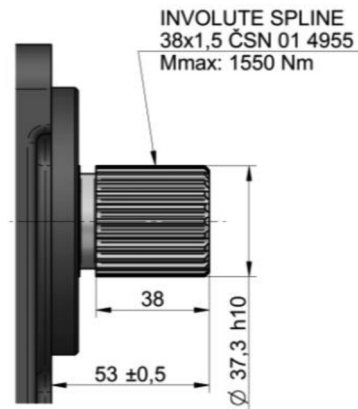

D27:

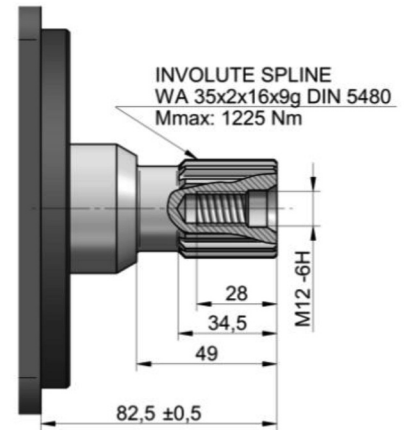

V17:

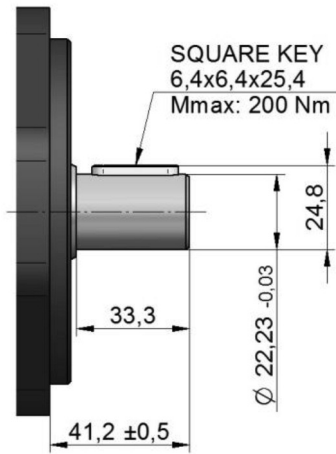

V18:

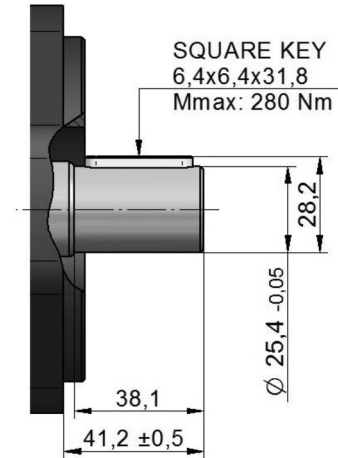

V19:

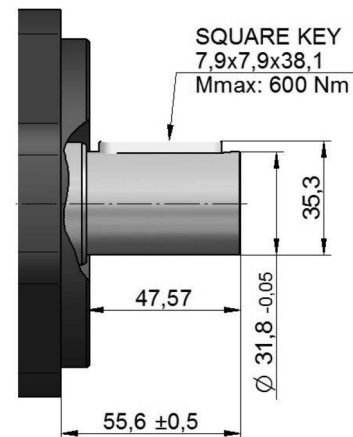

LIQUID INLET AND OUTLET CONNECTION

Metric thread according to ISO 6149

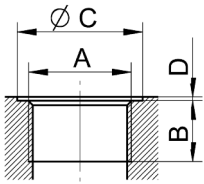

Displacement [cm ³]	Code	Inlet				Code	Outlet			
		A	B	C	D		A	B	C	D
GHD1 17-51	M12	M 33x2	18	40	1	M09	M 27x2	16	33	1
GHD2 51-150	M15	M 48x2	22	56	1	M12	M 33x2	18	40	1

BSPP pipe thread according to ISO 228-1

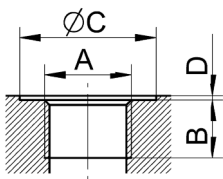

Displacement [cm ³]	Code	Inlet				Code	Outlet			
		A	B	C	D		A	B	C	D
GHD1 17-34	G05	G 1"	18	45	1	G04	G 3/4"	16	39	1
GHD1 34-71	G06	G 1 1/4"	24	58	1	G05	G 1"	18	45	1
GHD2 51-71	G06	G 1 1/4"	24	58	1	G05	G 1"	18	45	1
GHD2 71-100	G07	G 1 1/2"	26	64	1	G06	G 1 1/4"	24	58	1
GHD2 100-150	G09	G 2"	32	78	1	G07	G 1 1/2"	26	64	1

UNF thread according to SAE

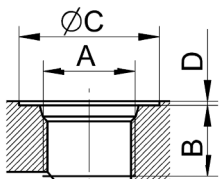

Displacement [cm ³]	Code	Inlet				Code	Outlet			
		A	B	C	D		A	B	C	D
GHD1 17-34	U07	1-5/16-12UN	19	49	1	U05	1-1/16-12UN	19	41	1
GHD1 34-71	U08	1-5/8-12UN	19	58	1	U07	1-5/16-12UN	19	49	1
GHD2 51-80	U08	1-5/8-12UN	19	58	1	U07	1-5/16-12UN	19	49	1
GHD2 80-150	U09	1-7/8-12UN	19	65	1	U08	1-5/8-12UN	19	58	1

Flanged fittings according to DIN 8901/8902

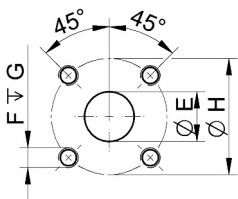

Displacement [cm ³]	Code	Inlet				Code	Outlet			
		E	F	G	H		E	F	G	H
GHD1 17-51	H10	25	M8	16	55	H09	18	M8	16	55

Note: Usable only as side inputs

Flanged fittings according to SAE, metric thread

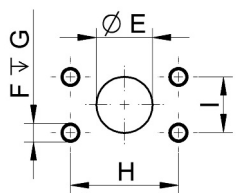

Displacement [cm ³]	Code	Inlet					Code	Outlet				
		E	F	G	H	I		E	F	G	H	I
GHD1 17-34	E03	25.4	M10	22	52.4	26.2	E02	19.0	M10	22	47.6	22.2
GHD1 34-51	E04	30.5	M10	22	58.7	30.2	E03	25.4	M10	22	52.4	26.2
GHD2 51-71	E05	39.3	M12	27	69.8	35.7	E04	30.5	M10	22	58.7	30.2
GHD2 51-82	E05	39.3	M12	27	69.8	35.7	E04	30.5	M10	22	58.7	30.2
GHD2 82-150	E06	51.0	M12	27	77.8	42.9	E05	39.3	M12	27	69.8	35.7

Note: Usable only as side inputs

Flanged fittings according to SAE, UNC thread

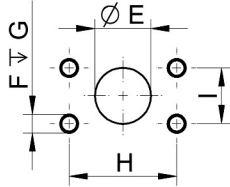

Displacement [cm ³]	Code	Inlet					Code	Outlet				
		E	F	G	H	I		E	F	G	H	I
GHD1 17-34	A03	25.4	3/8-16 UNC-2B	22.0	52.4	26.2	A02	19.0	3/8-16 UNC-2B	22.0	47.6	22.2
GHD1 34-71	A04	30.5	7/16-14 UNC-2B	28.5	58.7	30.2	A03	25.4	3/8-16 UNC-2B	22.0	52.4	26.2
GHD2 51-71	A05	39.3	1/2-13 UNC-2B	27.0	69.8	35.7	A04	30.5	7/16-14 UNC-2B	29.0	58.7	30.2
GHD2 51-82	A05	39.3	1/2-13 UNC-2B	27.0	69.8	35.7	A04	30.5	7/16-14 UNC-2B	29.0	58.7	30.2
GHD2 82-150	A06	51.0	1/2-13 UNC-2B	27.0	77.8	42.9	A05	39.3	1/2-13 UNC-2B	27.0	69.8	35.7

Note: Usable only as side inputs

Flanged fittings - „cross“

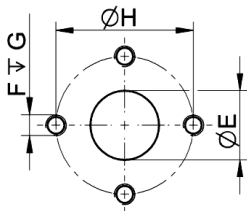

Displacement [cm ³]	Code	Inlet				Code	Outlet			
		E	F	G	H		E	F	G	H
GHD1 17-51	K04	26	M10	18	51	K03	18	M8	18	40
GHD1 17-51	K06	25	M8	16	55	K05	18	M8	16	55

Note: Usable only as side inputs

Flanged fittings - „square“

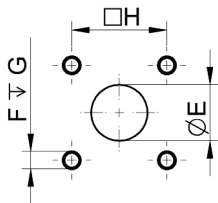

Displacement [cm ³]	Code	Inlet				Code	Outlet			
		E	F	G	H		E	F	G	H
GHD1 17-51	S06	30	M10	22	48	S05	22	M10	22	48
GHD2 51-150	S04	46	M12	24	78	S04	46	M12	24	78

Note: S04 – usable only as side inputs

S05, S06 – usable as axial and side input at GHD2 series

Drains:

Displacement [cm ³]	Code	Outlet			
		A	B	C	D
all	M05	M 18 x 1.5	14	24	1
all	G03	G 1/2"	14	33	1

CATALOGUE SHETS OF GHD1 SERIES BASIC DESIGNS

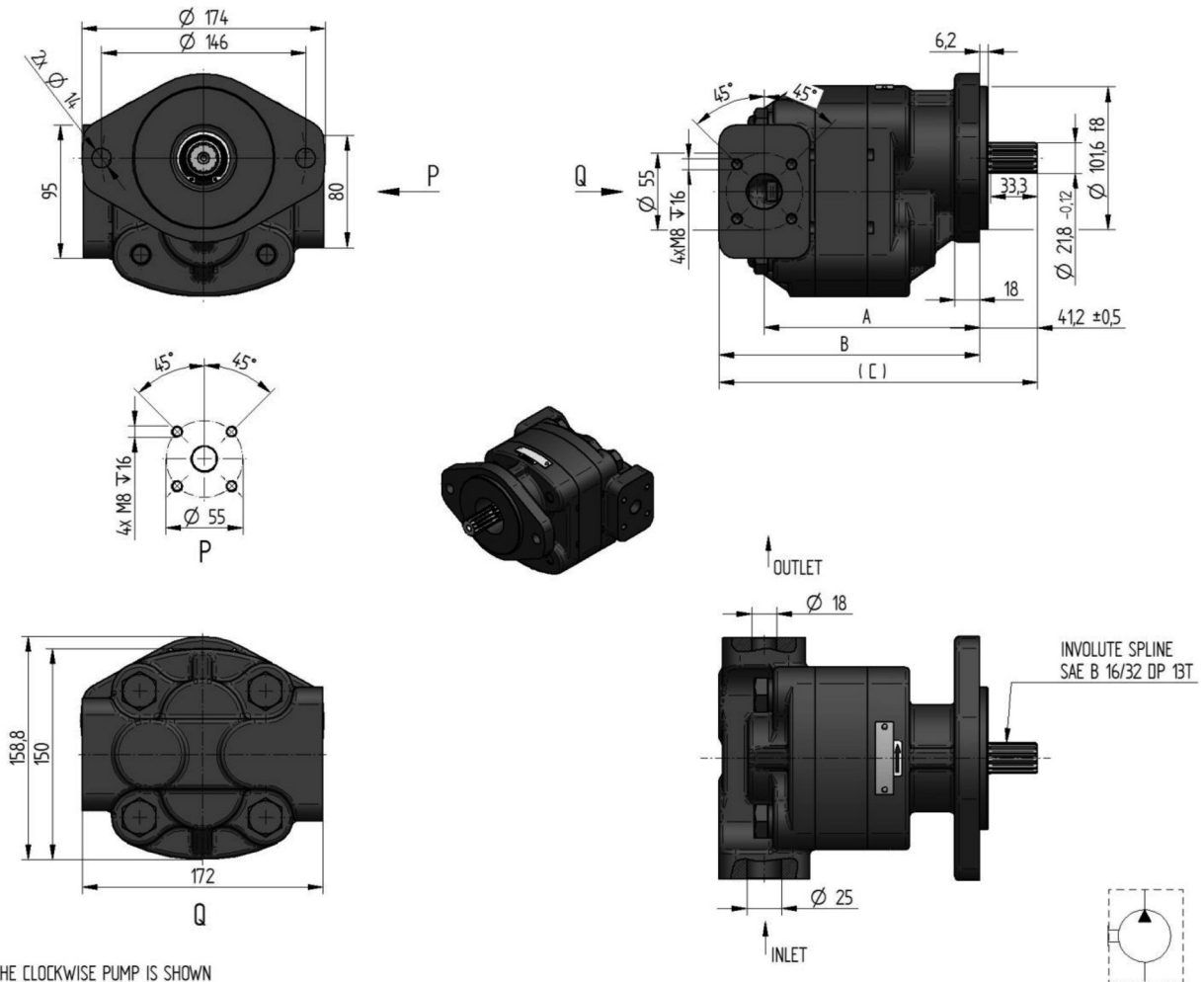

THE CLOCKWISE PUMP IS SHOWN

Order key	purch. code	direct. of rot.	displacement [cm ³ /1]	nom. press. [bar]	speed MIN. [min ⁻¹]	speed MAX. [min ⁻¹]	dimension		
							A [mm]	B [mm]	C [mm]
GHD1-71R-S03D13-SH10H09-N		R	71	210	250	1 800	63.7	128.5	168.3
GHD1-71L-S03D13-SH10H09-N		L							
GHD1-51R-S03D13-SH10H09-N		R	51	260	350	2 600	59.0	119.1	158.9
GHD1-51L-S03D13-SH10H09-N		L							
GHD1-43R-S03D13-SH10H09-N		R	43	280	400	2 800	48.8	98.6	138.4
GHD1-43L-S03D13-SH10H09-N		L							
GHD1-34R-S03D13-SH10H09-N		R	34	300	400	3 000	45.6	92.3	132.1
GHD1-34L-S03D13-SH10H09-N		L							
GHD1-27R-S03D13-SH10H09-N		R	27	300	400	3 200	44.0	89.2	129.0
GHD1-27L-S03D13-SH10H09-N		L							
GHD1-17R-S03D13-SH10H09-N		R	17	300	400	3 200	42.5	86.0	125.8
GHD1-17L-S03D13-SH10H09-N		L							

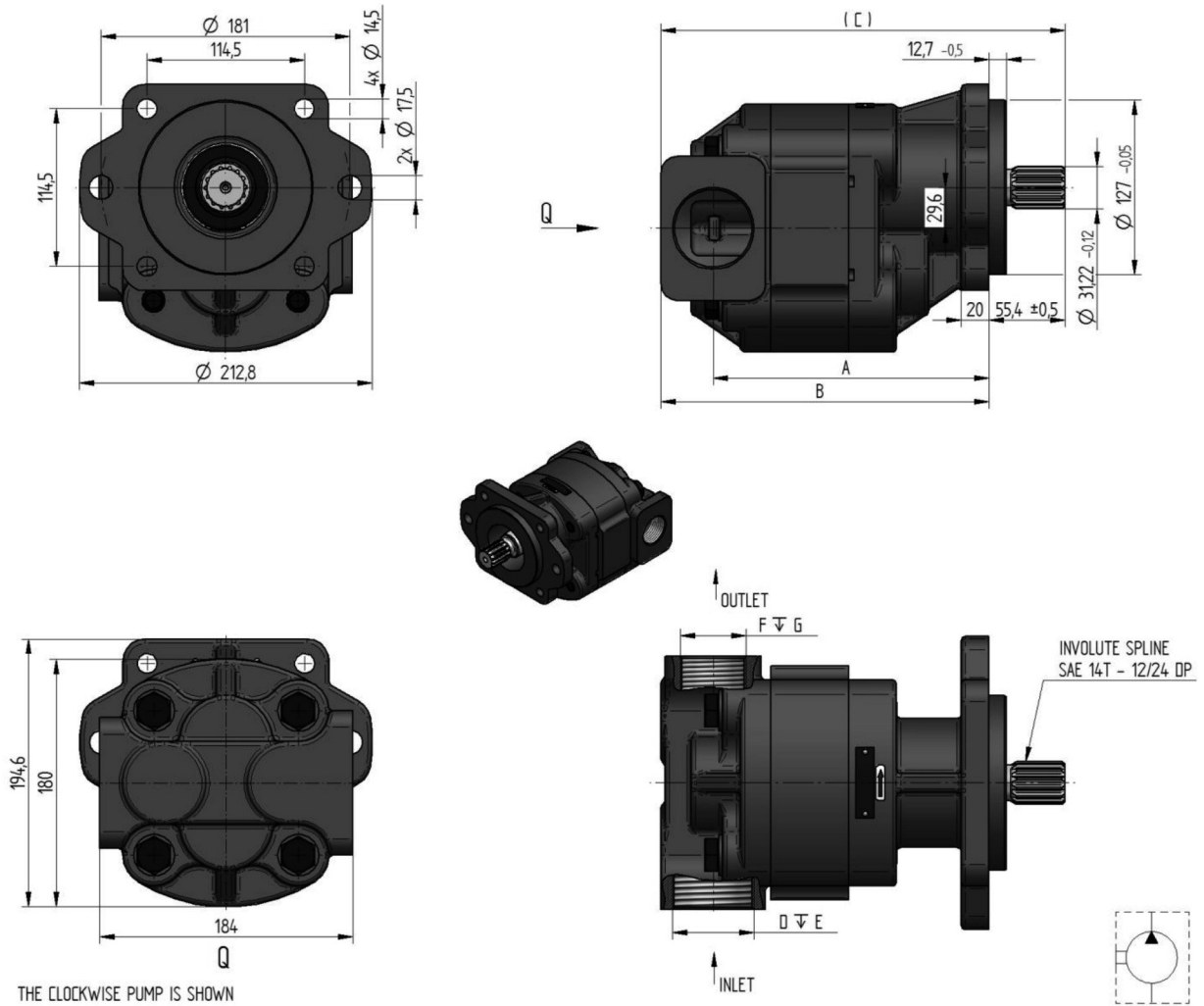

Order key	purch. code	direct. of rot.	displacement [cm ³ /1]	nom. press. [bar]	speed MIN. [min ⁻¹]	speed MAX. [min ⁻¹]	dimension						
							A [mm]	B [mm]	C [mm]	D [mm]	E [mm]	F [mm]	G [mm]
GHD2-150R-S06D14-SG09G07-N		R	150	170	250	2000	222.0	260.0	315.4	G 2"	32	G 1 1/2"	26
GHD2-150L-S06D14-SG09G07-N		L											
GHD2-125R-S06D14-SG09G07-N		R	125	190	250	2400	211.5	249.5	304.9	G 2"	32	G 1 1/2"	26
GHD2-125L-S06D14-SG09G07-N		L											
GHD2-110R-S06D14-SG09G07-N		R	110	210	350	2600	205.0	243.0	298.4	G 2"	32	G 1 1/2"	26
GHD2-110L-S06D14-SG09G07-N		L											
GHD2-100R-S06D14-SG07G06-N		R	100	230	350	2700	200.5	238.5	293.9	G 1 1/2"	26	G 1 1/4"	24
GHD2-100L-S06D14-SG07G06-N		L											
GHD2-90R-S06D14-SG07G06-N		R	90	240	400	2800	196.5	234.5	289.9	G 1 1/2"	26	G 1 1/4"	24
GHD2-90L-S06D14-SG07G06-N		L											
GHD2-82R-S06D14-SG07G06-N		R	82	260	400	3000	193.0	231.0	286.4	G 1 1/2"	26	G 1 1/4"	24
GHD2-82L-S06D14-SG07G06-N		L											
GHD2-71R-S06D14-SG06G05-N		R	71	260	400	3200	188.5	226.5	281.9	G 1 1/4"	24	G 1"	18
GHD2-71L-S06D14-SG06G05-N		L											
GHD2-61R-S06D14-SG06G05-N		R	61	270	400	3200	184.0	222.0	277.4	G 1 1/4"	24	G 1"	18
GHD2-61L-S06D14-SG06G05-N		L											
GHD2-56R-S06D14-SG06G05-N		R	56	280	400	3200	182.0	220.0	275.4	G 1 1/4"	24	G 1"	18
GHD2-56L-S06D14-SG06G05-N		L											
GHD2-51R-S06D14-SG06G05-N		R	51	280	400	3200	180.0	218.0	273.4	G 1 1/4"	24	G 1"	18
GHD2-51L-S06D14-SG06G05-N		L											

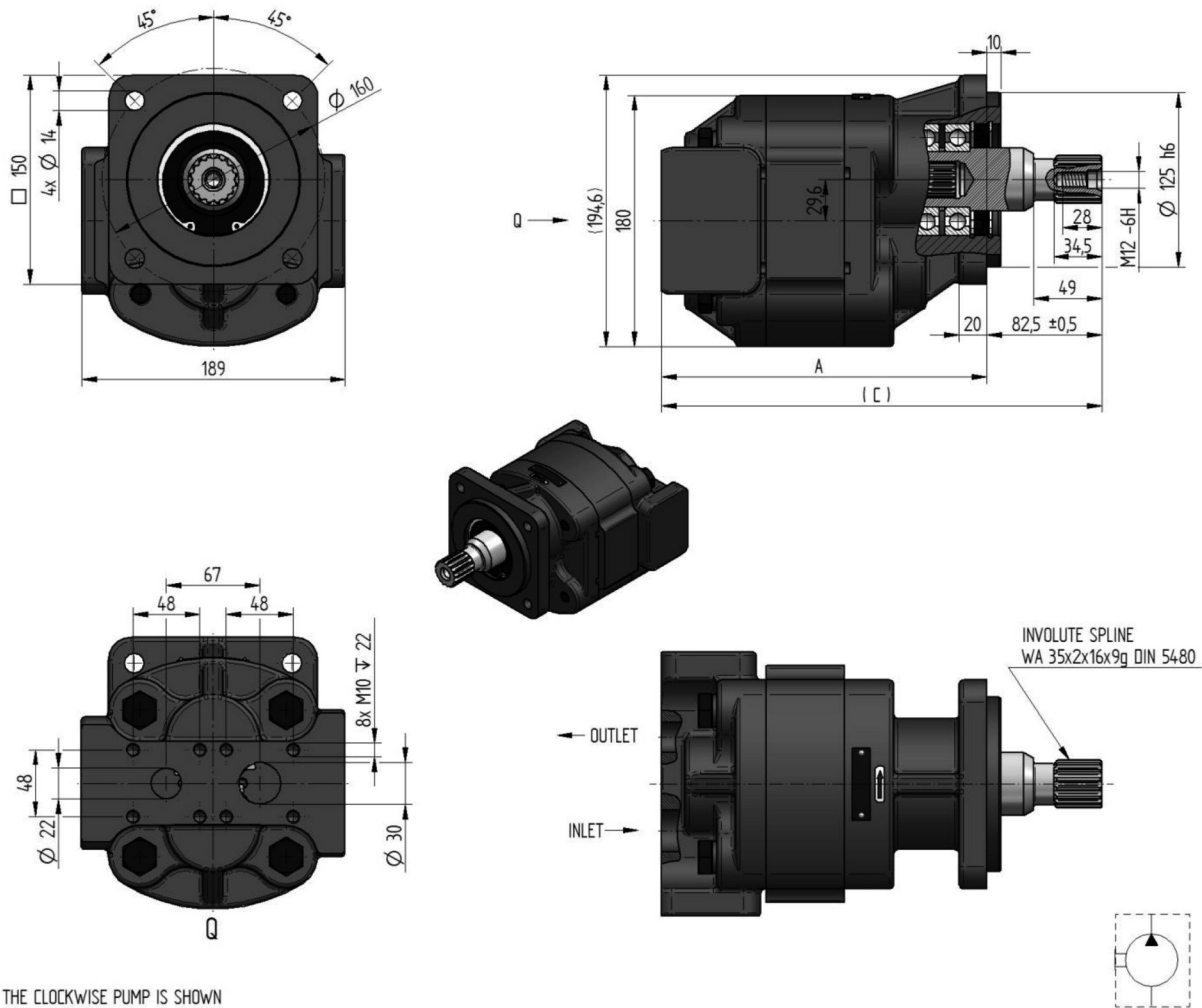

THE CLOCKWISE PUMP IS SHOWN

Order key	purch. code	direct. of rot.	displacement [cm ³ /1]	nom. press. [bar]	speed MIN. [min ⁻¹]	speed MAX. [min ⁻¹]	dimension	
							A [mm]	C [mm]
GHD2-150R-F03D27-RS06S05-N.001		R	150	170	250	2000	255.0	337.5
GHD2-150L-F03D27-RS06S05-N.001		L						
GHD2-125R-F03D27-RS06S05-N.001		R	125	190	250	2400	244.5	327.0
GHD2-125L-F03D27-RS06S05-N.001		L						
GHD2-110R-F03D27-RS06S05-N.001		R	110	210	350	2600	238.0	320.5
GHD2-110L-F03D27-RS06S05-N.001		L						
GHD2-100R-F03D27-RS06S05-N.001		R	100	230	350	2700	233.5	316.0
GHD2-100L-F03D27-RS06S05-N.001		L						
GHD2-90R-F03D27-RS06S05-N.001		R	90	240	400	2800	229.5	312.0
GHD2-90L-F03D27-RS06S05-N.001		L						
GHD2-82R-F03D27-RS06S05-N.001		R	82	260	400	3000	226.0	308.5
GHD2-82L-F03D27-RS06S05-N.001		L						
GHD2-71R-F03D27-RS06S05-N.001		R	71	260	400	3200	221.5	304.0
GHD2-71L-F03D27-RS06S05-N.001		L						
GHD2-61R-F03D27-RS06S05-N.001		R	61	270	400	3200	217.0	299.5
GHD2-61L-F03D27-RS06S05-N.001		L						
GHD2-56R-F03D27-RS06S05-N.001		R	56	280	400	3200	215.0	297.5
GHD2-56L-F03D27-RS06S05-N.001		L						
GHD2-51R-F03D27-RS06S05-N.001		R	51	280	400	3200	213.0	295.5
GHD2-51L-F03D27-RS06S05-N.001		L						

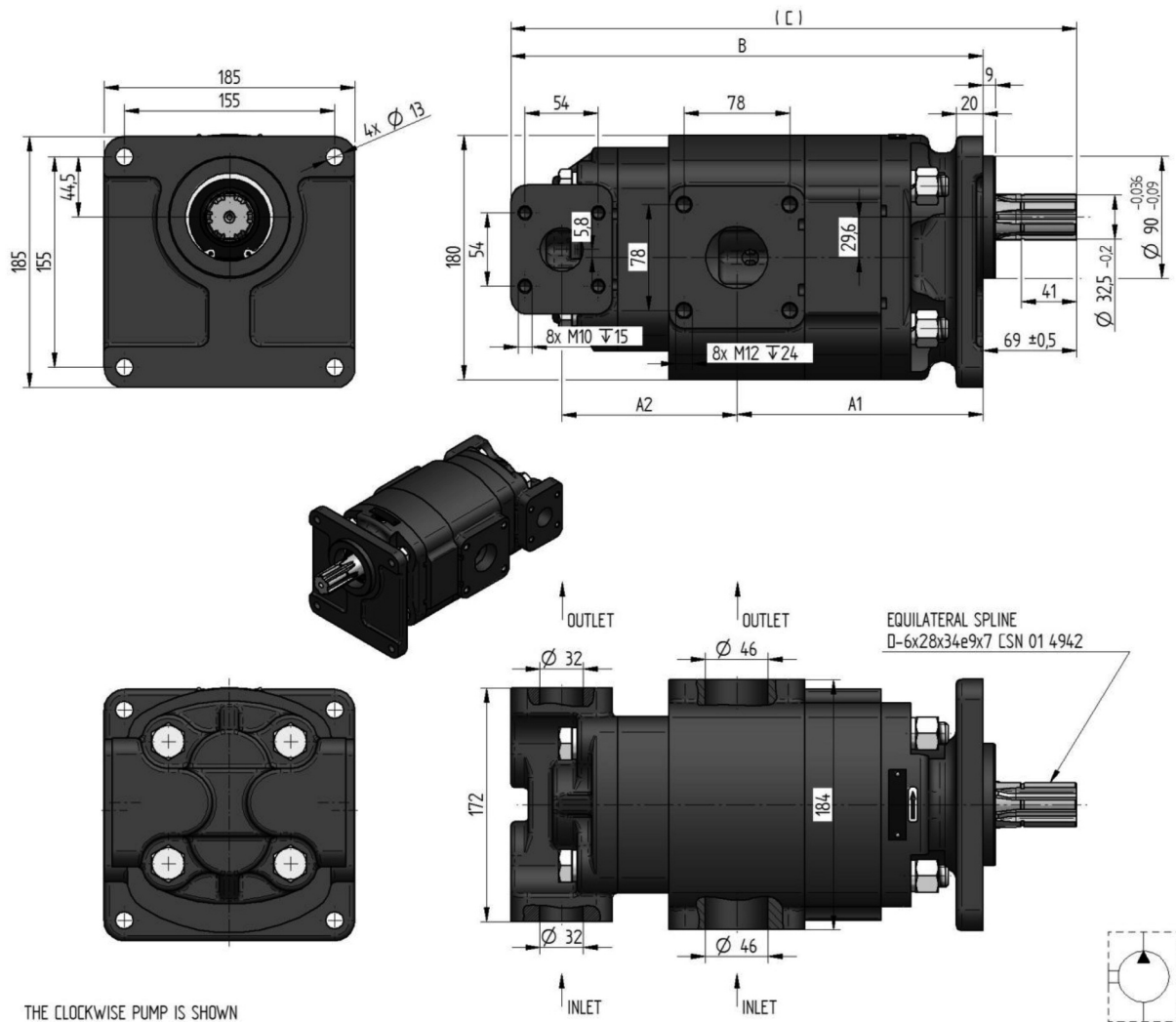

THE CLOCKWISE PUMP IS SHOWN

Order key	purch. code	direct. of rot.	displacement [cm ³ /1]	nom. press. [bar]	speed MIN. [min ⁻¹]	speed MAX. [min ⁻¹]	dimension			
							A1 [mm]	A2 [mm]	B [mm]	C [mm]
GHD2-100/GHD1-51R-R15D25-SS04S04/S07S07-N		R	100/51	230/260	350	2 600	181.5	141.0	360.0	429.0
GHD2-100/GHD1-51L-R15D25-SS04S04/S07S07-N		L								

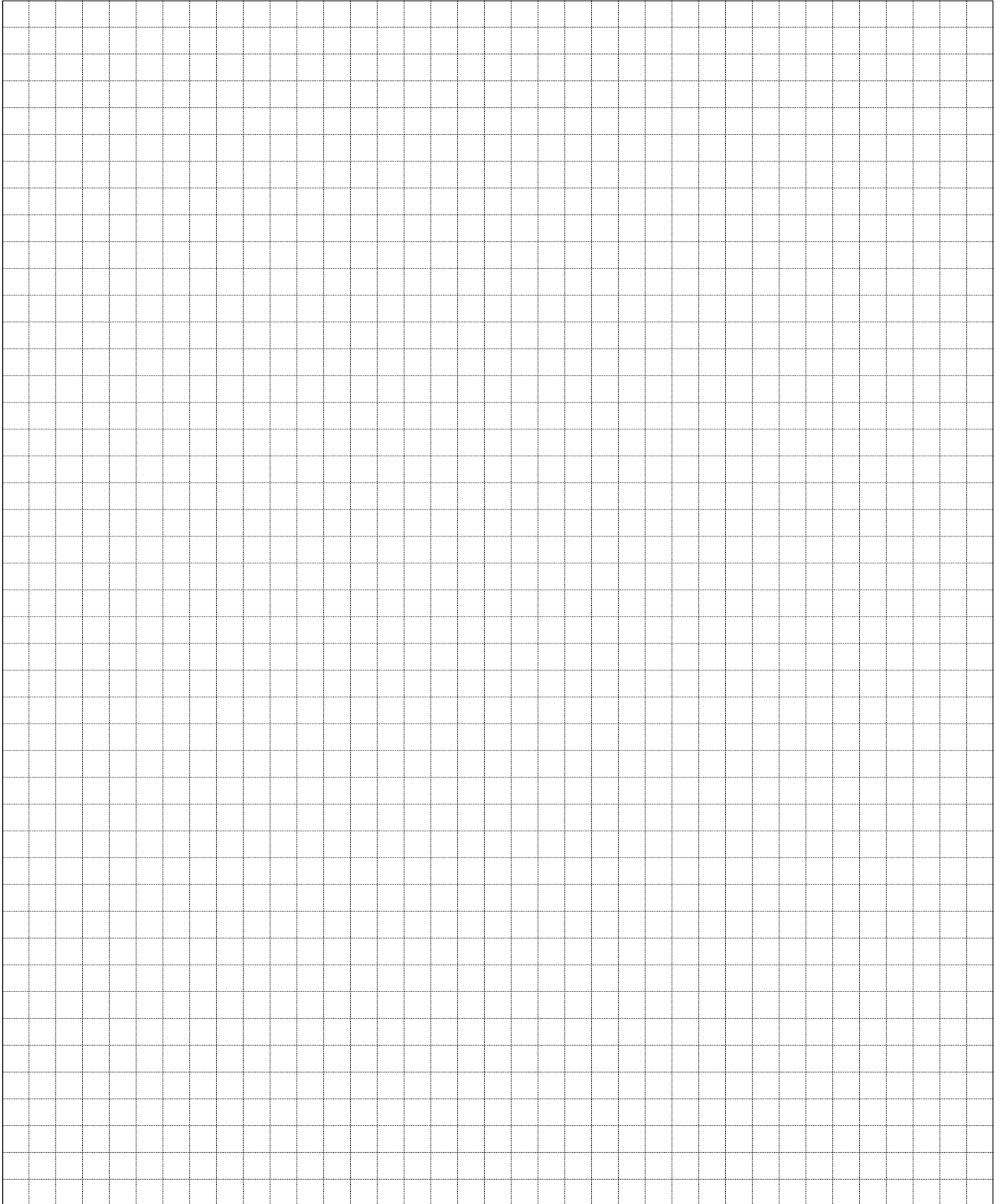

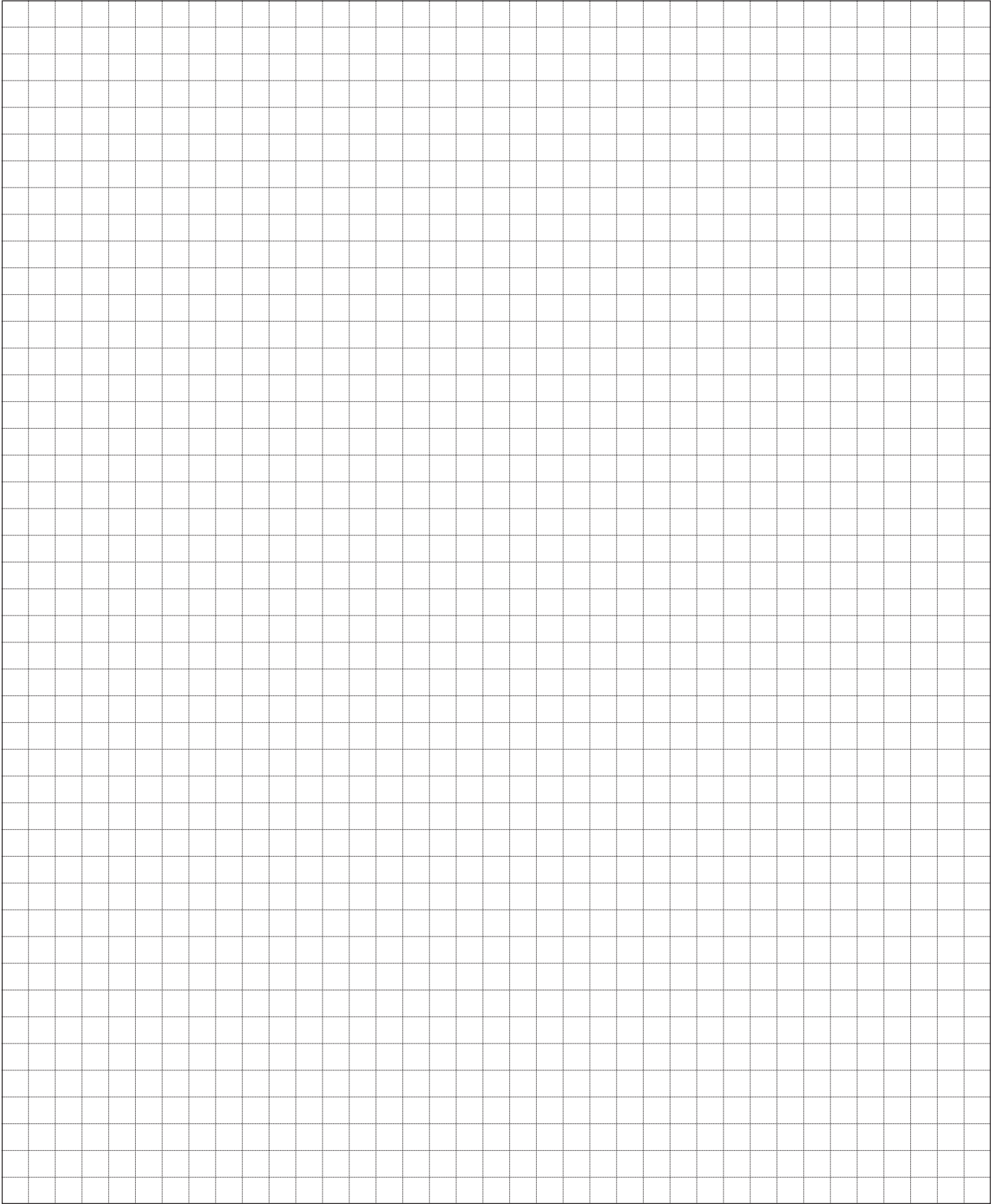

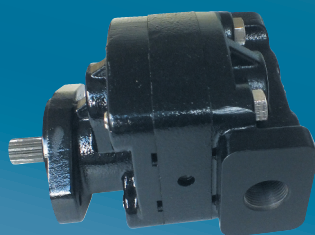

jihostroj
AERO TECHNOLOGY & HYDRAULICS

JIHOSTROJ a.s.
Budějovická 148
CZ 382 32 Velešín
Czech Republic
tel.: +420 380 340 511
fax: +420 380 340 612
e-mail: mailbox@jihostroj.cz
http: //www.jihostroj.com
GPS 48°49'51.748" N 14°27'40.770" E

