

juhostroj
AERO TECHNOLOGY & HYDRAULICS

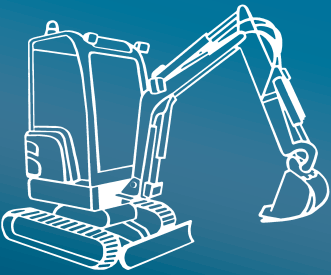

Displacement from 10 to 36 ccm
Pressure up to 300 bar
Speed from 350 to 3400 RPM

GEAR PUMPS
GHDO

TABLE OF CONTENTS

DESCRIPTION.....	2
BASIC PARTS OF PUMP.....	2
PARAMETER TABLE.....	3
FORMULAS USED FOR CALCULATION.....	4
PUMP EFFICIENCIES.....	4
WORKING LIQUID.....	5
PRESSURE LOAD.....	5
OTHER REQUIREMENTS.....	6
DIRECTION OF ROTATION.....	6
REVERSIBLE DESIGN.....	6
GHDO FLOW RATE AND POWER CURVES.....	7
ORDER KEY - SINGLE VERSION.....	12
ORDER KEY - MULTIPLE VERSION.....	13
COMBINATIONS OF FLANGES AND SHAFTS.....	14
FLANGE DESIGN.....	15
DRIVE SHAFTS.....	16
LIQUID INLET AND OUTLET CONNECTION.....	17
CATALOGUE SHETS OF GHDO SERIES BASIC DESIGNS.....	19
NOTES.....	29

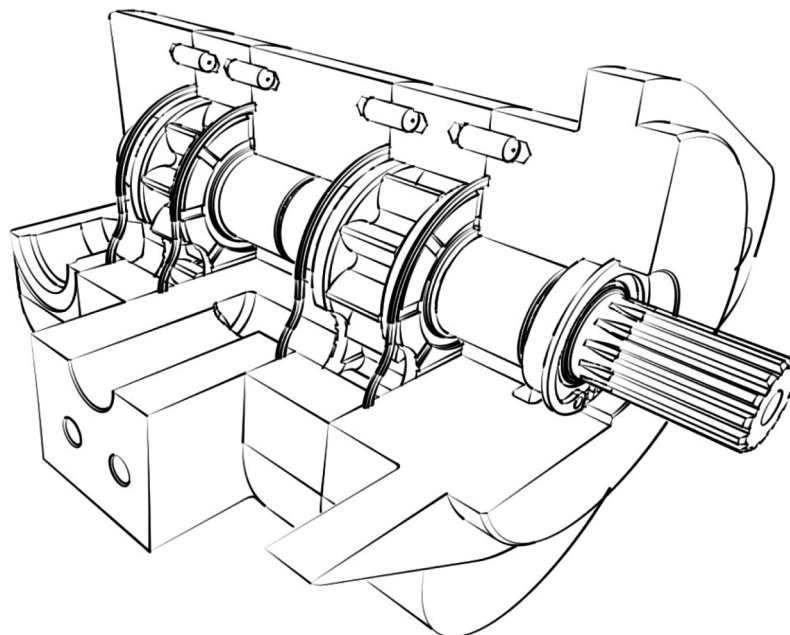

DESCRIPTION

- Due to their robust iron-cast structure, the GHDO series pumps with external gearing are intended for the heaviest applications in the area of agricultural and building machines. The GHDO series covers the range of displacements from 10 to 36 cm³/rev.
- These pumps are characterized by a three-part, all-cast-iron structure: flange – body – cover. Bushings supporting gear studs are pressed into the flange and the cover. Gear wheels, which are optimised to achieve a low noise level, are made of ultrahigh-strength steel. Liquid inlet and outlet are located in the cover (thus, the body is not weakened by them and a higher pressure load is possible) from sides or axially in the cover. The axial power balancing is performed using sliding aluminium alloy pressure plates in which a shape sealing of balancing surface is located in grooves. The flange dimensions enable a design with a pre-shaft with bearings for a higher radial or axial load of the drive.
- The GHDO pumps are produced in various designs of drives, clamping flanges as well as liquid inlets and outlets. These pumps comply with the standards ISO, SAE, UNI and other world-recognised standards, they can be delivered in one-way single-section as well as multiple-section designs. They can also be delivered in a reversible design, with external or internal drainage.

BASIC PARTS OF PUMP

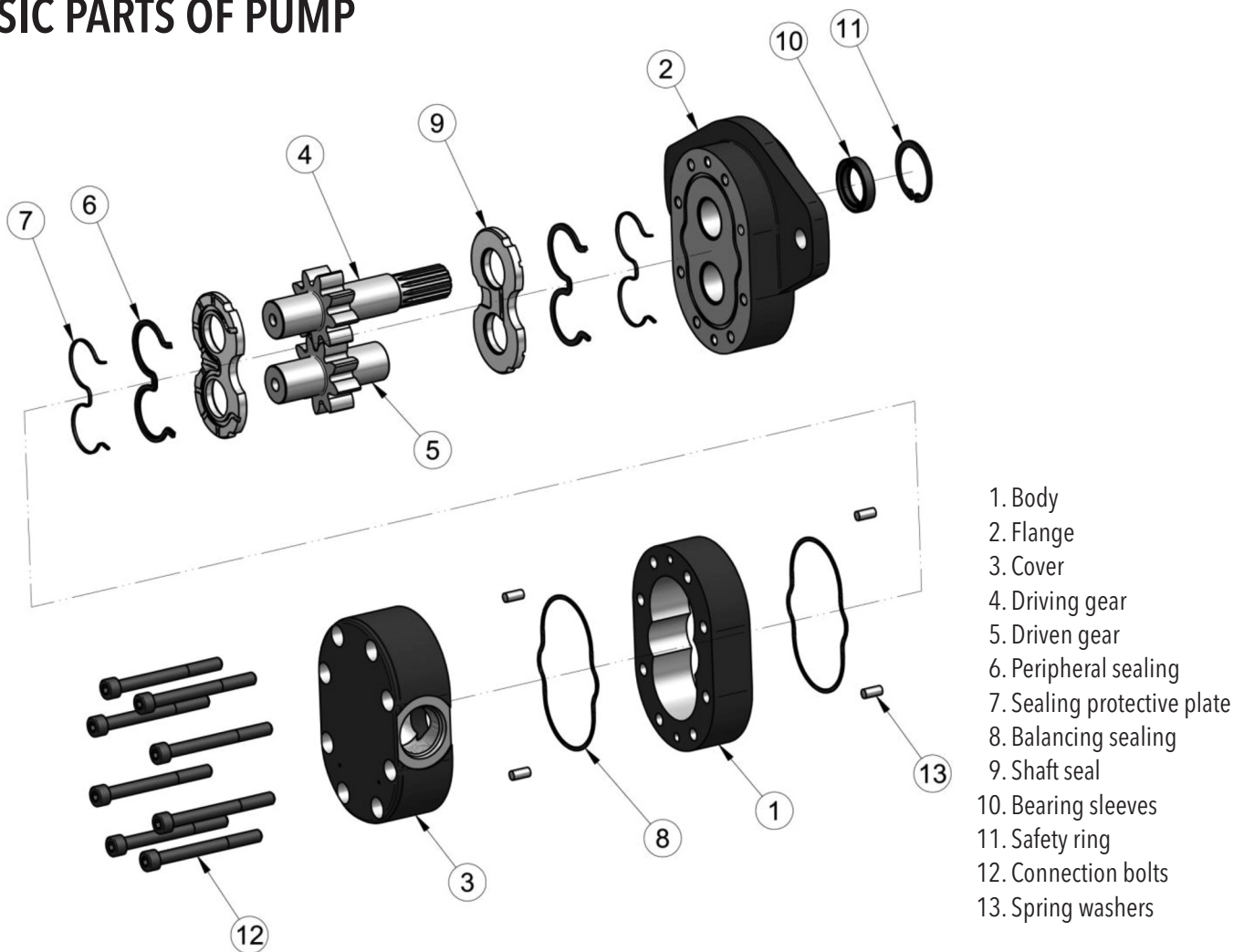

1. Body
2. Flange
3. Cover
4. Driving gear
5. Driven gear
6. Peripheral sealing
7. Sealing protective plate
8. Balancing sealing
9. Shaft seal
10. Bearing sleeves
11. Safety ring
12. Connection bolts
13. Spring washers

PARAMETER TABLE

Nominal Size Parameters		Sym.	Unit.	GHDO 7	GHDO 10	GHDO 13	GHDO 17	GHDO 19	GHDO 23	GHDO 27
Actual displacement		V_g	[cm ³]	7.21	9.71	12.85	17.31	19.41	22.95	27.54
Rotation speed	nominal	n_n	[min ⁻¹]	1500	1500	1500	1500	1500	1500	1500
	minimum	n_{min}	[min ⁻¹]	400	400	400	350	350	350	350
	maximum	n_{max}	[min ⁻¹]	3400	3400	3400	3400	3400	3400	3400
Pressure at inlet*	minimum	p_{1min}	[bar]	-0.4	-0.4	-0.4	-0.4	-0.4	-0.4	-0.4
	maximum	p_{1max}	[bar]	0.6	0.6	0.6	0.6	0.6	0.6	0.6
Pressure at outlet**	max. continuous	p_{2n}	[bar]	300	300	300	300	295	295	290
	maximum	p_{2max}	[bar]	320	320	320	320	315	315	310
	peak	p_3	[bar]	330	330	330	330	325	325	320
Nominal flow rate (min.) at n_n and p_{2n}		Q_n	[dm ³ .min ⁻¹]	9.9	13.5	18.1	24.4	27.4	32.4	38.8
Maximum flow rate at n_{max} a p_{2max}		Q_{max}	[dm ³ .min ⁻¹]	22.6	30.7	41.1	55.3	62.0	73.3	88.0
Nominal input power (max.) at n_n and p_{2n}		P_n	[kW]	6.6	8.8	11.5	15.5	17.0	20.1	23.8
Maximum input power at n_{max} a p_{2max}		P_{max}	[kW]	15.9	21.2	27.7	37.4	41.2	48.8	57.6
Weight		m	[kg]	8.7	8.8	9.0	9.2	9.4	9.8	10.1

Nominal Size Parameters		Sym.	Unit.	GHDO 29	GHDO 32	GHDO 36	GHDO 38	GHDO 41	GHDO 44	GHDO 51
Actual displacement		V_g	[cm ³]	29.64	32.66	36.72	38.82	41.84	44.99	52.07
Rotation speed	nominal	n_n	[min ⁻¹]	1500	1500	1500	1500	1500	1500	1500
	minimum	n_{min}	[min ⁻¹]	350	350	350	350	350	350	350
	maximum	n_{max}	[min ⁻¹]	3200	3000	2700	2600	2400	2300	2000
Pressure at inlet*	minimum	p_{1min}	[bar]	-0.4	-0.4	-0.4	-0.4	-0.4	-0.4	-0.4
	maximum	p_{1max}	[bar]	0.6	0.6	0.6	0.6	0.6	0.6	0.6
Pressure at outlet**	max. continuous	p_{2n}	[bar]	290	280	250	240	225	220	210
	maximum	p_{2max}	[bar]	310	300	270	260	245	240	230
	peak	p_3	[bar]	320	310	280	270	255	250	240
Nominal flow rate (min.) at n_n and p_{2n}		Q_n	[dm ³ .min ⁻¹]	41.8	46.1	51.8	54.7	59.0	63.4	73.4
Maximum flow rate at n_{max} a p_{2max}		Q_{max}	[dm ³ .min ⁻¹]	89.2	92.1	93.2	94.9	94.4	97.3	97.9
Nominal input power (max.) at n_n and p_{2n}		P_n	[kW]	25.6	27.2	27.3	27.7	28.0	29.5	32.5
Maximum input power at n_{max} a p_{2max}		P_{max}	[kW]	58.3	58.3	53.1	52.1	48.8	49.3	47.5
Weight		m	[kg]	10.2	10.4	10.6	10.7	10.9	11.1	11.4

* Inlet pressure in the reversible design can be up to $p_1 = p_{2n} - 70$ bar max. External drainage must be used in case of the reversible design.

** Outlet pressure in the reversible design is **10% lower** than shown in the table (depending on operating conditions - it is necessary to consult with the manufacturer).

FORMULAS USED FOR CALCULATION

Flow rate
 Q

$$Q = \frac{V_g \cdot n}{1000} \cdot \eta_v \quad [\text{dm}^3 \cdot \text{min}^{-1}]$$

V_g [cm³] pump displacement
 n [min⁻¹] rotation speed
 η_v [-] volumetric efficiency

Displacement
 V_g

$$V_g = \frac{Q \cdot 1000}{n \cdot \eta_v} \quad [\text{cm}^3]$$

Torque
 M_k

$$M_k = \frac{V_g \cdot p}{20 \cdot \pi \cdot \eta_m} \quad [\text{Nm}]$$

p [bar] required pressure at outlet
 η_m [-] mechanical efficiency

Input power
 P

$$P = \frac{V_g \cdot n \cdot p}{600 \cdot 1000 \cdot \eta_t} \quad [\text{kW}]$$

η_t [-] total efficiency

PUMP EFFICIENCIES

Volumetric efficiency

η_v

It determines the amount of flow losses. Its value is $\eta_v = 0,92 \div 0,98$ (depending on rotation speed, viscosity of working liquid and outlet pressure). It can be expressed as follows:

$$\eta_v = \frac{Q_{act.}}{Q_{theor}} \quad [-]$$

$Q_{act.}$ [dm³ · min⁻¹] actual flow rate
 Q_{theor} [dm³ · min⁻¹] theoretical flow rate

Mechanical efficiency

η_m

It determines mechanical losses. Its value is about $\eta_m = 0,85$. It can be expressed as follows:

$$\eta_m = \frac{M_{theor}}{M_{act.}} \quad [-]$$

$M_{act.}$ [Nm] actual torque
 M_{theor} [Nm] theoretical torque

Total efficiency

η_t

t is defined as product of η_n and η_m and determines difference between theoretical and actual required input power:

$$\eta_t = \eta_v \cdot \eta_m = \frac{P_{theor}}{P_{act.}} \quad [-]$$

$P_{act.}$ [kW] actual input power
 P_{theor} [kW] theoretical input power

WORKING LIQUID

- Mineral oils for hydraulic drives
- Hydraulic liquids based on plant oils suitable for hydraulic drives

Liquid temperature

- $t = -20 \div +80$ [°C]
when used with FKM (Viton) seal up to 120 [°C]

Cinematic viscosity

- Recommended (during continuous operation): $\nu = 20 \div 80 \cdot 10^{-6} [\text{m}^2 \cdot \text{s}^{-1}]$
- Maximum (cold starting, at viscosity >1000 , operating pressure <10 bar is permissible, speed $<1500 \cdot \text{min}^{-1}$): $\nu = 1200 \cdot 10^{-6} [\text{m}^2 \cdot \text{s}^{-1}]$
- Minimum (operating mode at $10 \cdot 10^{-6}$ up $20 \cdot 10^{-6}$ should be consulted with manufacturer): $\nu = 10 \cdot 10^{-6} [\text{m}^2 \cdot \text{s}^{-1}]$

Filtration coefficient β_α

$\beta_{25\ 75} \geq$ (for pressure $p_2 < 200$ bar)
 $\beta_{10\ 75} \geq$ (for pressure $p_2 > 200$ bar)

Liquid contamination class according to ISO 4406

21/18/15 (for pressure $p_2 < 200$ bar)
20/17/14 (for pressure $p_2 > 200$ bar)

Liquid contamination class according to NAS 1638

10 (for pressure $p_2 < 200$ bar)
8 (for pressure $p_2 > 200$ bar)

PRESSURE LOAD

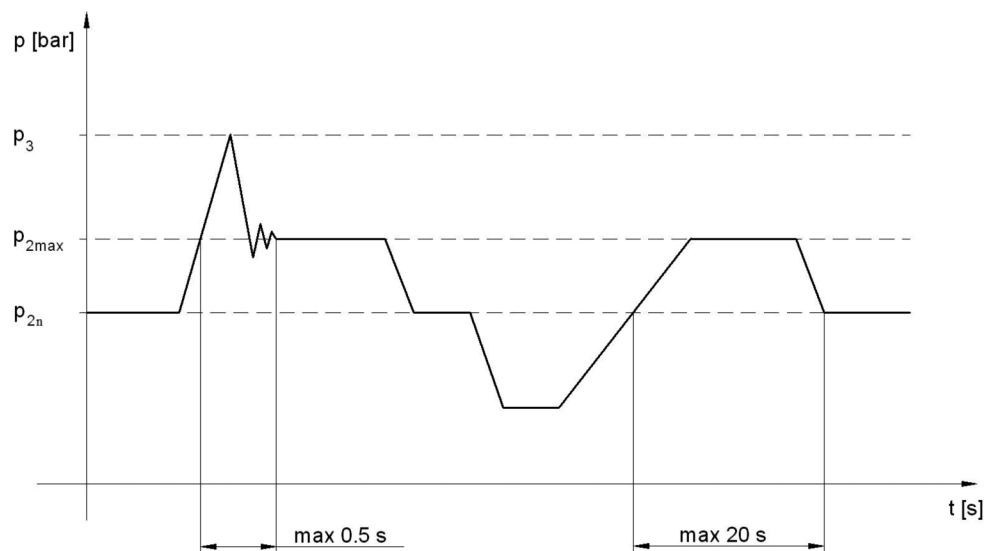

- p_{2n} **max. contin. pressure** Max. working pressure, at which the pump can be operated without time limitation.
- p_{2max} **max. pressure** Maximum pressure permissible for a short time, max. 20s.
- p_3 **peak pressure** Short-time pressure (fractions of a second) arising in case of a sudden change of the operating mode; any excess of this pressure during operation is impermissible.

OTHER REQUIREMENTS

- A driving device must not generate an axial or a radial load of the pump shaft, unless this is exclusively permitted for the pump with a front-end bearing.
- All the matters affecting technical parameters and properties of the pump are given in respective operating manuals, technical specifications and test specifications of the manufacturer.

DIRECTION OF ROTATION

- Determine direction of rotation by looking at the drive shaft. The pump can only be used in the specified direction of rotation.



REVERSIBLE DESIGN

- The pumps with the possibility of bidirectional rotation have a different internal arrangement requiring drainage. Two types of drain are used - internal and external. The internal drainage is always interconnected with the outlet by means of valves. The external drainage is solved by an orifice located in the cover opposite the driven gear.

GHDO FLOW RATE AND POWER CURVES

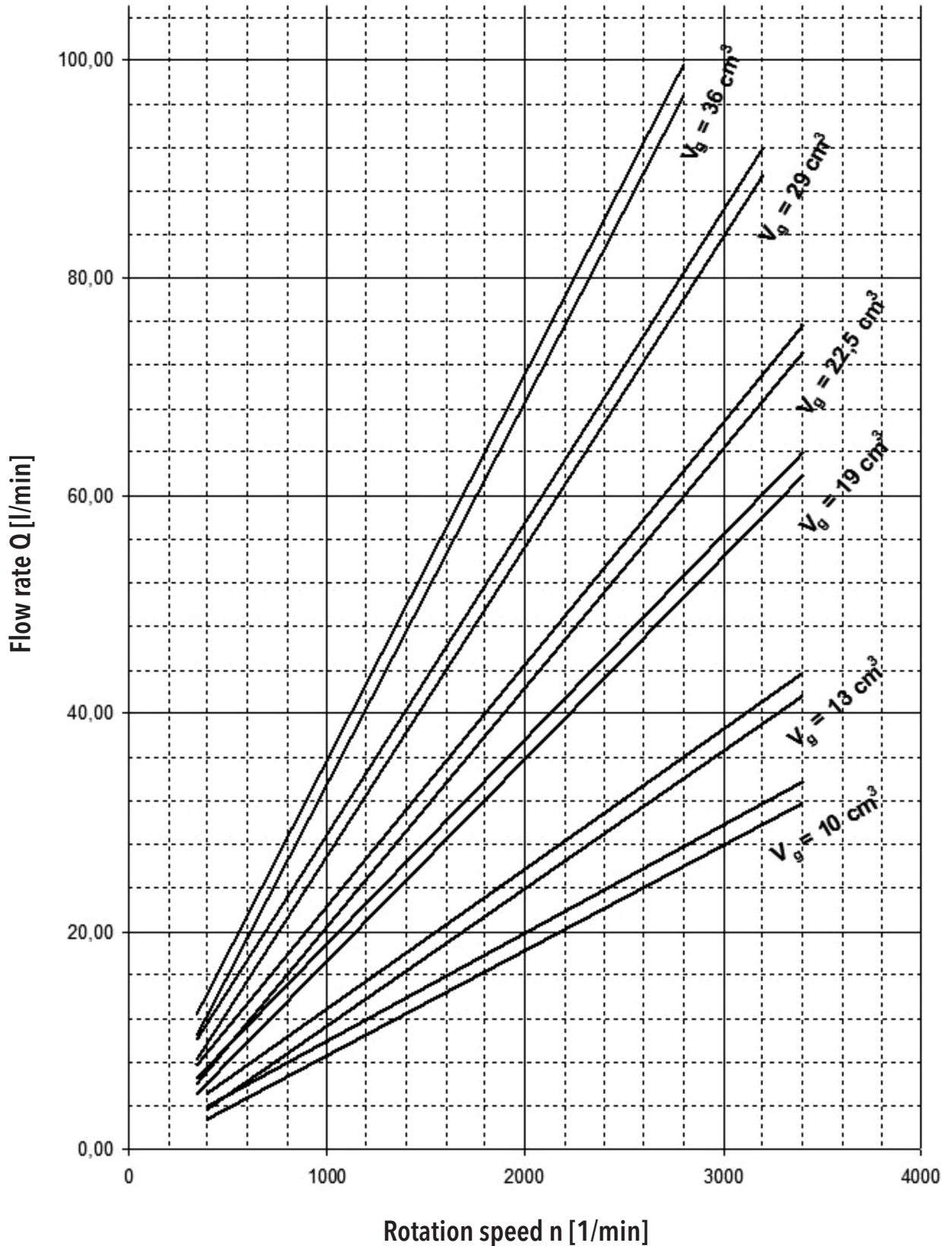

Above curves apply to ISO Vg 46 oil at temperature $t = 45^\circ\text{C}$.

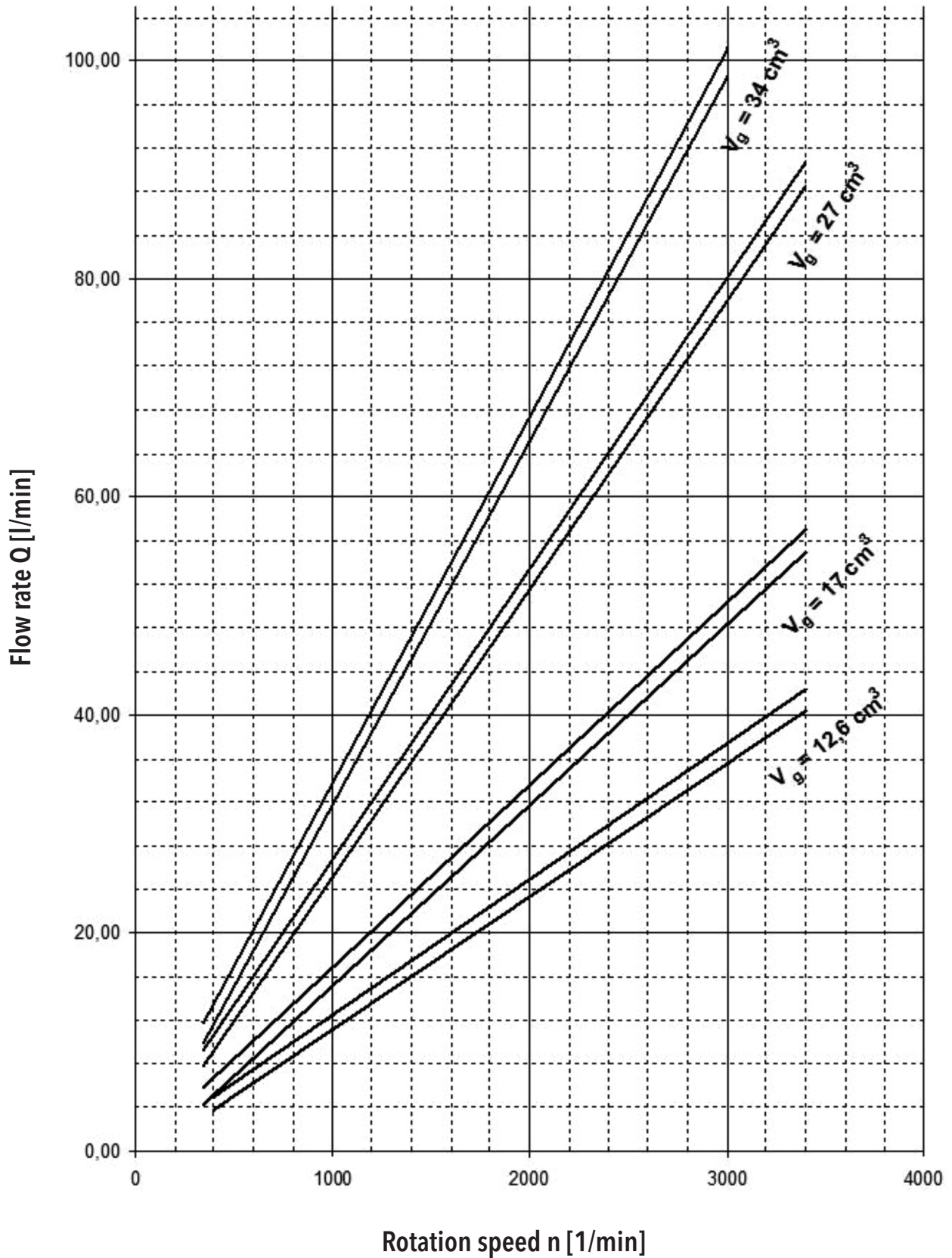

Above curves apply to ISO V_g 46 oil at temperature t = 45°C.

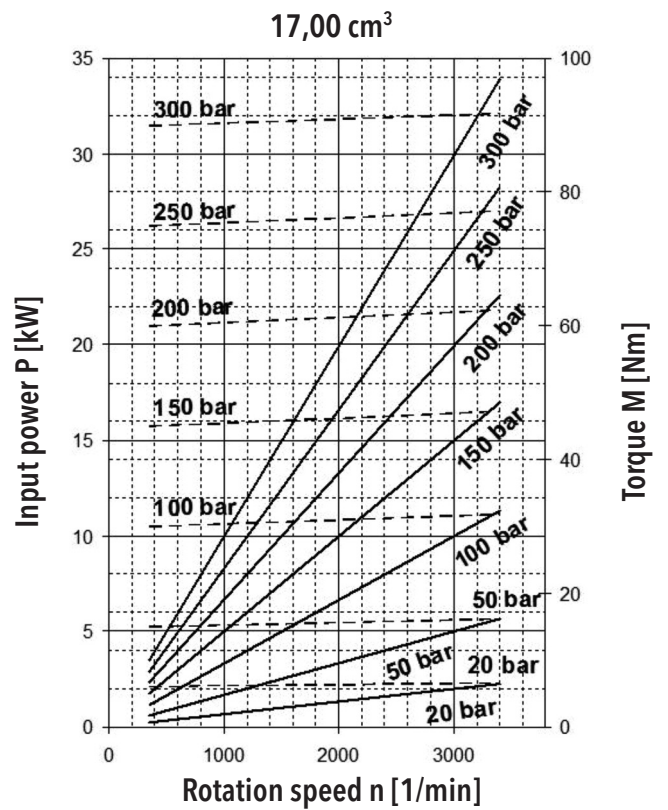
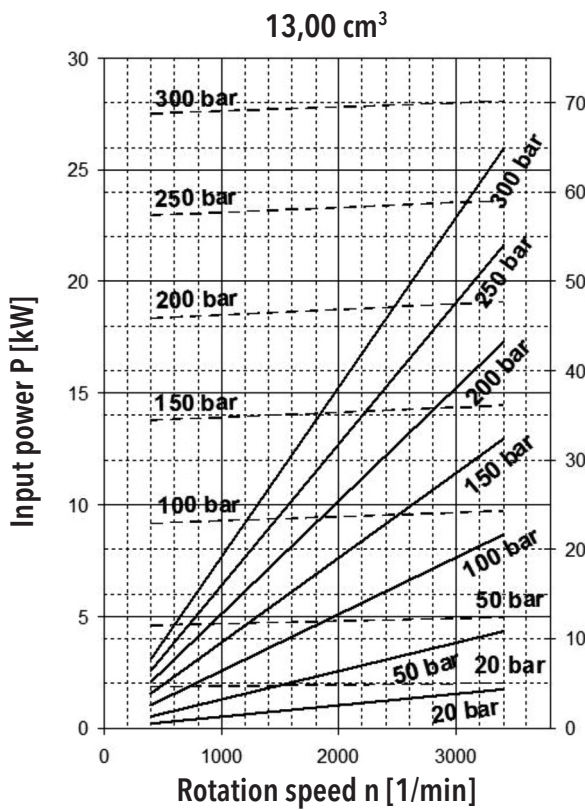
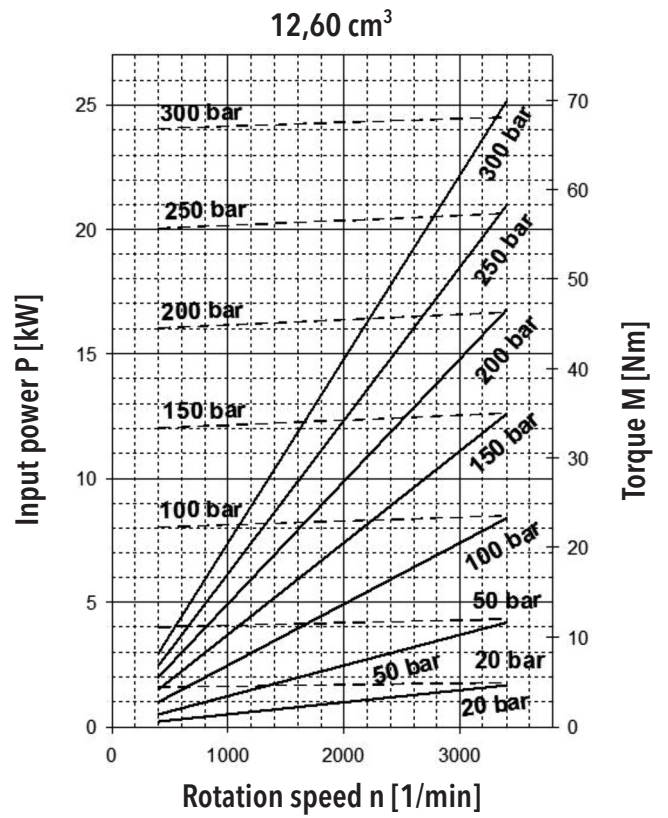
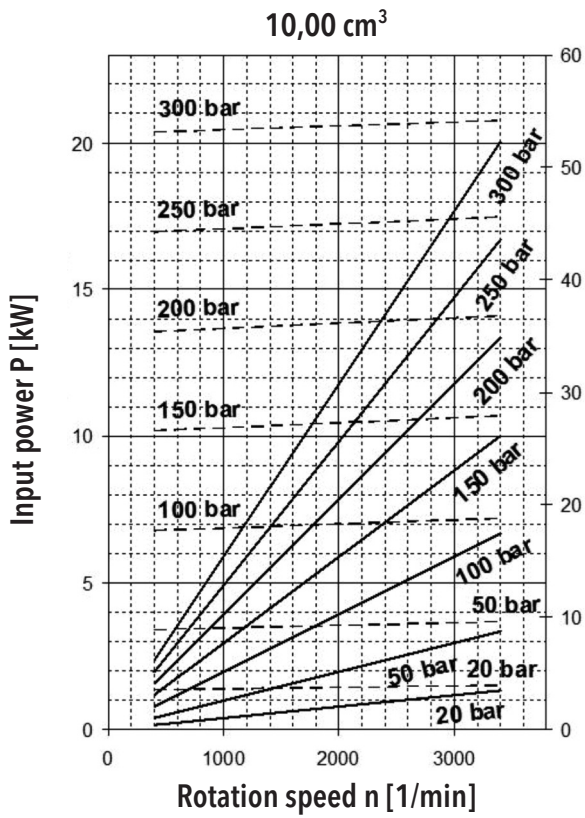

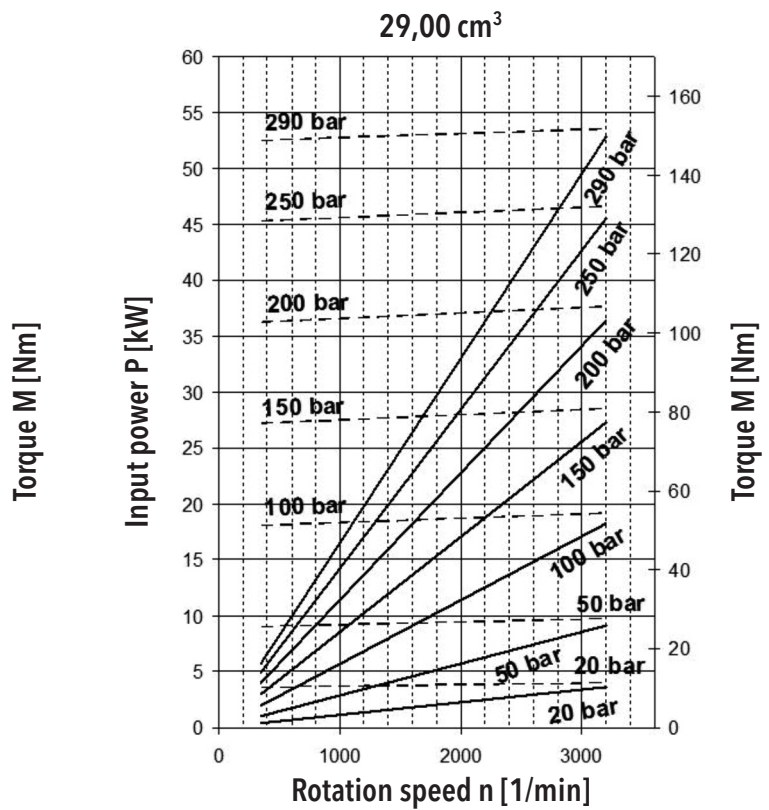
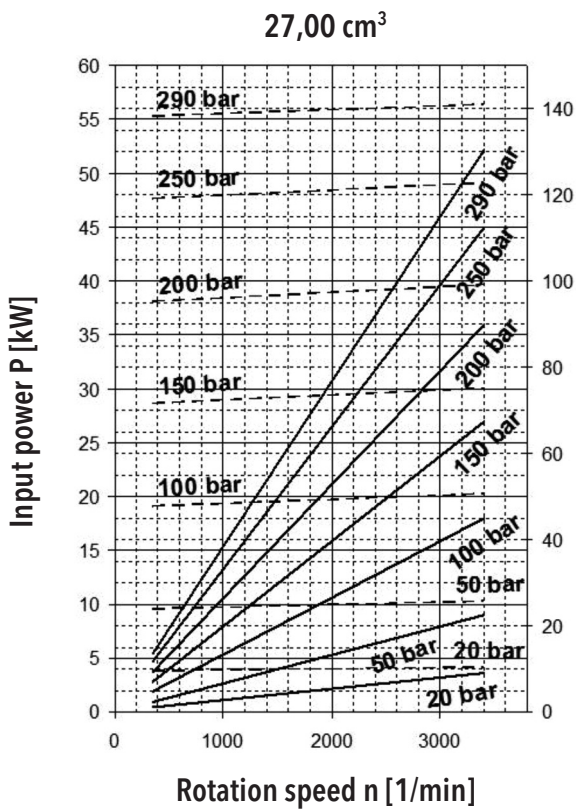
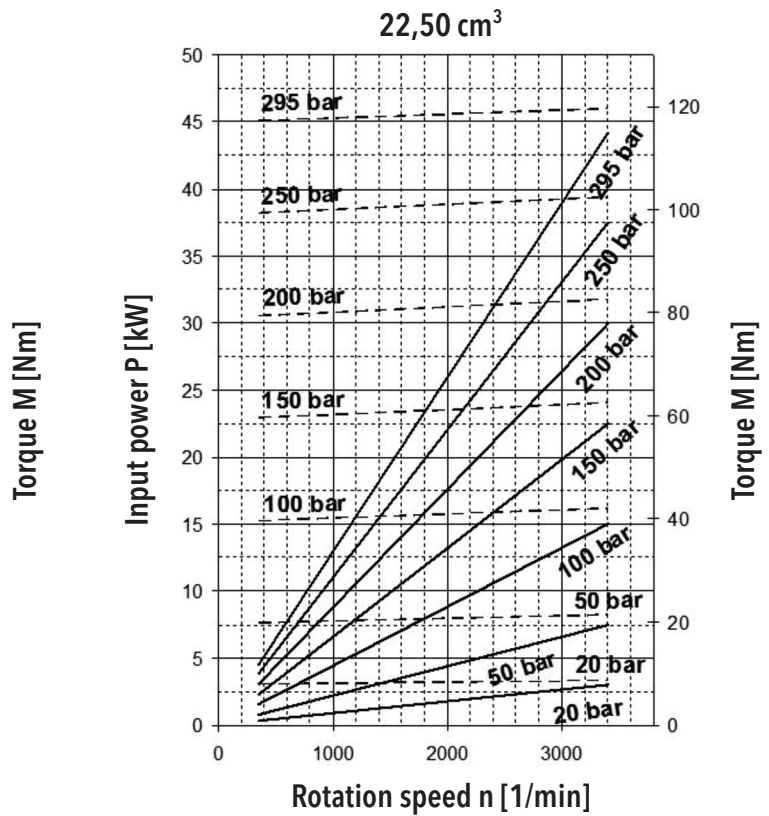
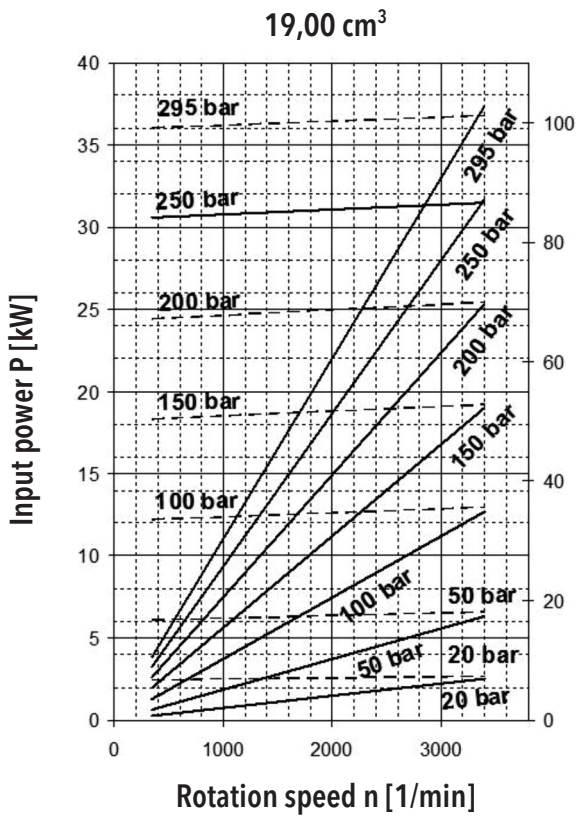

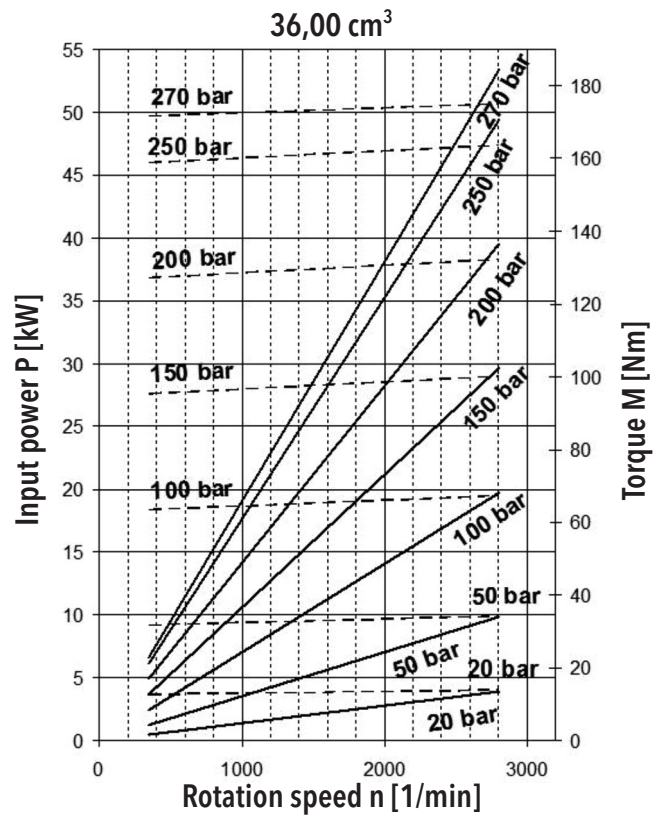
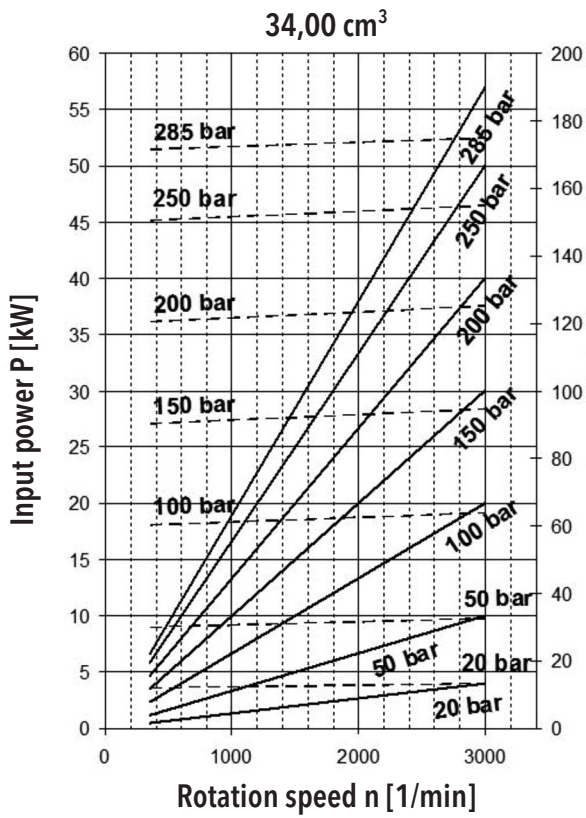

ORDER KEY - SINGLE VERSION

GHDO - 22,5 R - S03 D13 - S U07 U05 - N . 001

Code	Type
GHDO	GHDO Series Gear Pump

Code	Displacement [cm ³]
10	10,016
12,6	12,584
13	12,970
17	16,951
19	19,005
22,5	22,472
27	26,967
29	29,021
34	34,029
36	35,956
38	38,010
XX	Other displacements on request*

Code	Direction of rotation
R	Clockwise
L	Anti-clockwise
B	Bi-directional

Code	Flange design	
R09		Square, centre ring Ø62 Spacing screw 86 x 120
R11		Square, centre ring Ø50,8 Spacing screw 98,5 x 128
S02		SAE A - 2 apertures
S03		SAE B - 2 apertures
I02		ISO, centre ring Ø80
U01		UNI
Z		Special desing

Code	Location of inlets and outlets	
S		Side (in the body)
R		Axial (in the cover)
C		Combination

Code	Special arrangements
-	No special arrangements
001	With front-end bearing
004	Without shaft seal

Code	Seal material
N	NBR
V	FKM (VITON)
H	HNBR

Code	Drive shaft desing	
C11		Cone 1:8
D04		Spline SAE 9T
D06		Spline SAE 11T
D12		Spline 22x1
D13		Spline SAE B 13T
D15		Spline SAE BB 15T
D17		Spline UNI 221
D18		Equilateral spline A8x32x36x6 DIN5462
D23		Spline UNI 221
V17		Cylindric SAE B, Ø22,22 Key 6,4 x 6,4 x 25,4
Z		Special desing

Code	Liquid inlet and outlet connection shape	
M07		Thread M 22x1,5
M08		Thread M 27x1,5
M09		Thread M 27x2
M11		Thread M 33x1,5
M12	Thread M 33x2	
G03		Thread BSP G1/2
G04		Thread BSP G3/4
G05		Thread BSP G1"
U03		Thread 3/4-16 UNF
U04		Thread 7/8-14 UNF
U05		Thread 1-1/16-12 UN
U07	Thread 1-5/16-12 UN	
H07		Fitting Ø13,5; 4xM6/Ø30
H08		Fitting Ø20; 4xM8/Ø40
H09		Fitting Ø18; 4xM8/Ø55
H10		Fitting Ø25; 4xM8/Ø55
A02		Fitting SAE (SSS) 3/4
A03		Fitting SAE (SSS) 1"
A04		Fitting SAE (SSS) 1 1/4
E02		Fitting SAE (SSM) 3/4
E03		Fitting SAE (SSM) 1"
E04		Fitting SAE (SSM) 1 1/4
K03		Fitting Ø18; 4xM8 / Ø40
K04		Fitting Ø26; 4xM10/Ø51
K05		Fitting Ø18; 4xM8 / Ø55
K06		Fitting Ø25; 4xM8 / Ø55
S05		Fitting Ø22, 4xM10/48x48
Z		Special desing

An example of designation for the GHDO clockwise pump with displacement of 22.5 cm³, SAE B flange, SAE B spline, UNF side inlets and standard NBR seal without special arrangements: **GHDO-22.5R-S03D13-SU07U05-N**

ORDER KEY - MULTIPLE VERSION

GHDO - 29 / 17 L - S03 D13 - S U07 U05 / U07 U05 - N . 001

Code	Type
GHDO	GHDO Series Gear Pump

Code	Displacement [cm ³]
10	10,016
12,6	12,584
13	12,970
17	16,951
19	19,005
22,5	22,472
27	26,967
29	29,021
34	34,029
36	35,956
38	38,010
XX	Other displacements on request

Code	Direction of rotation
R	Clockwise
L	Anti-clockwise
B	Bi-directional

Code	Flange design
R09	Square, centre ring $\varnothing 62$ Spacing screw 86 x 120
R11	Square, centre ring $\varnothing 50,8$ Spacing screw 98,5 x 128
S02	SAE A - 2 apertures
S03	SAE B - 2 apertures
I02	ISO, centre ring $\varnothing 80$
U01	UNI
Z	Special desing

Code	Location of inlets and outlets
S	Side (in the body)
C	Combination

Code	Special arrangements
-	No special arrangements
001	With front-end bearing
004	Without shaft seal

Code	Seal material
N	NBR
V	FKM (VITON)
H	HNBR

Code	Drive shaft desing
C11	Cone 1:8
D04	Spline SAE 9T
D06	Spline SAE 11T
D12	Spline 22x1
D13	Spline SAE B 13T
D15	Spline SAE BB 15T
D17	Spline UNI 221
D18	Equilateral spline A8x32x36x6 DIN5462
D23	Spline UNI 221
V17	Cylindric SAE B, $\varnothing 22,22$ Key 6,4 x 6,4 x 25,4
Z	Special desing

Code	Liquid inlet and outlet connection shape
M07	Thread M 22x1,5
M08	Thread M 27x1,5
M09	Thread M 27x2
M11	Thread M 33x1,5
M12	Thread M 33x2
G03	Thread BSP G1/2
G04	Thread BSP G3/4
G05	Thread BSP G1"
U03	Thread 3/4-16 UNF
U04	Thread 7/8-14 UNF
U05	Thread 1-1/16-12 UN
U07	Thread 1-5/16-12 UN
H07	Fitting $\varnothing 13,5; 4xM6/\varnothing 30$
H08	Fitting $\varnothing 20; 4xM8/\varnothing 40$
H09	Fitting $\varnothing 18; 4xM8/\varnothing 55$
H10	Fitting $\varnothing 25; 4xM8/\varnothing 55$
A02	Fitting SAE (SSS) 3/4
A03	Fitting SAE (SSS) 1"
A04	Fitting SAE (SSS) 1 1/4
E02	Fitting SAE (SSM) 3/4
E03	Fitting SAE (SSM) 1"
E04	Fitting SAE (SSM) 1 1/4
K03	Fitting $\varnothing 18; 4xM8/\varnothing 40$
K04	Fitting $\varnothing 26; 4xM10/\varnothing 51$
K05	Fitting $\varnothing 18; 4xM8/\varnothing 55$
K06	Fitting $\varnothing 25; 4xM8/\varnothing 55$
S05	Fitting $\varnothing 22, 4xM10/48x48$
Z	Special desing

An example of designation for the GHDO two-section anti-clockwise pump with displacements of 29 and 17 cm³, SAE B flange, SAE B spline, UNF side inlets and standard NBR seal without special arrangements: **GHDO-29/17L-S03D13-SU07U05/U07U05-N**

Note: In case of combination inlets, with the code „C” is respected following sequence of inlets and outlets:

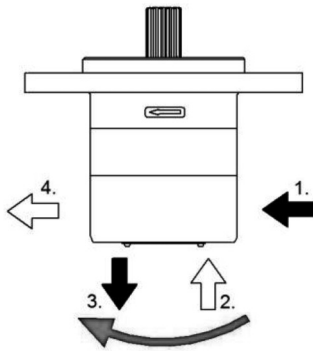

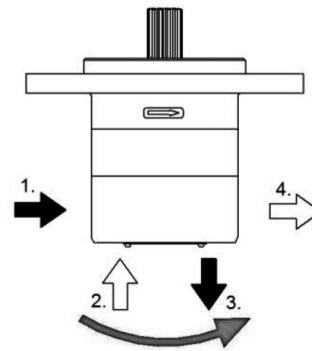

For clockwise and reverse gear pump,
in direction clockwise



For anti-clockwise gear pump,
in direction anti-clockwise

For. ex....: GHDO-43B-R11C11-CG05 G05 G04 G04 -N
1. 2. 3. 4.

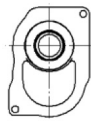
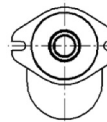
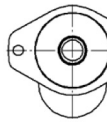
COMBINATIONS OF FLANGES AND SHAFTS

		FLANGE DESIGN					
		R11	R09	S02	S03	I02	U01
DRIVE SHAFT	C11						
	D04	●		●	●		
	D06			●	●		
	D12		●				
	D13			●	●		
	D15			●	●		
	D17						●
	D18					●	
	D23			●	●		
	V17		●	●	●		

FLANGES DESIGN

R09:

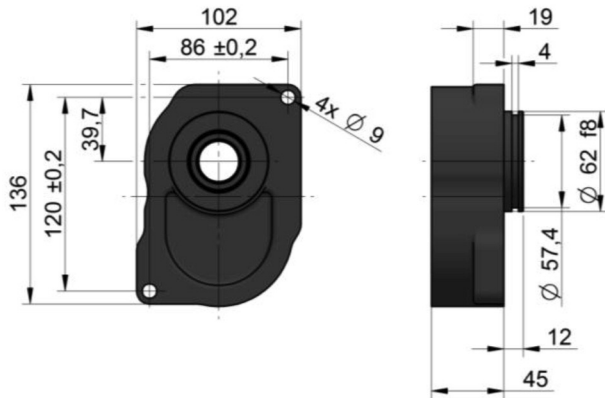

R11:

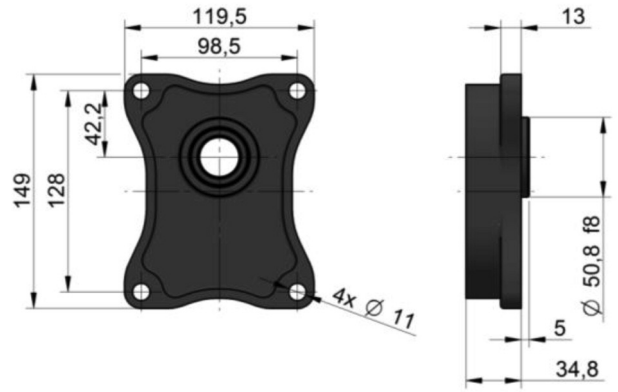

S02:

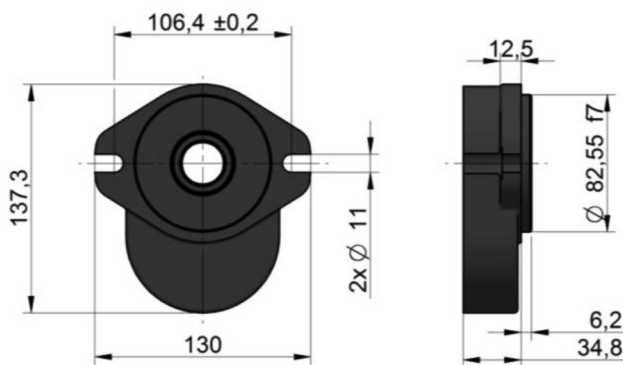

S03:

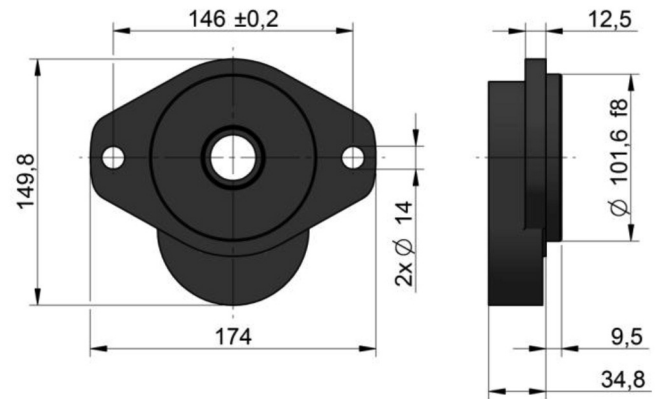

I01:

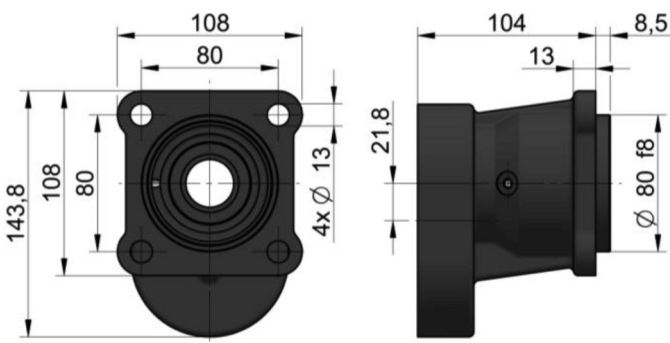

U01:

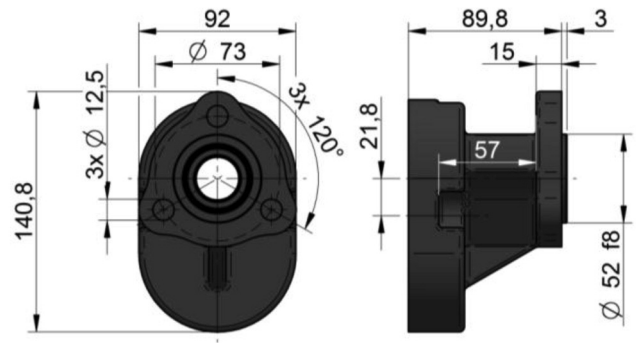

DRIVE SHAFTS

C11:

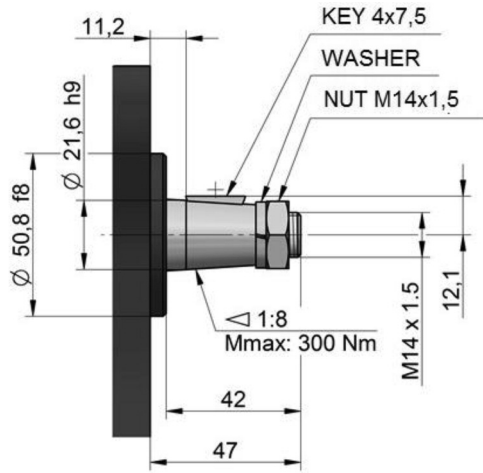

D04:

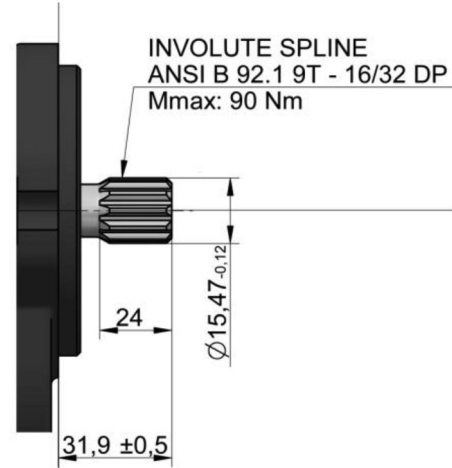

D06:

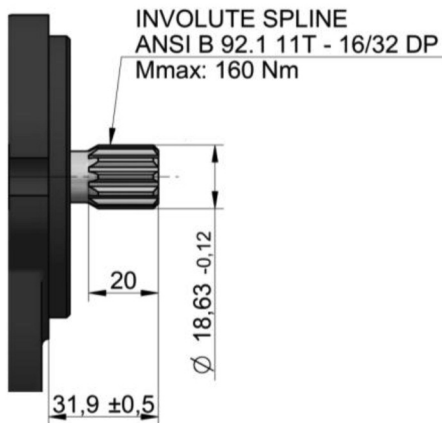

D12:

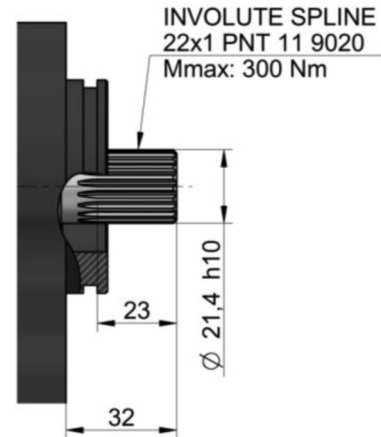

D13:

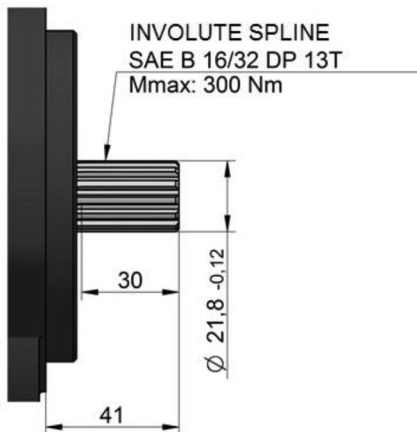

D15:

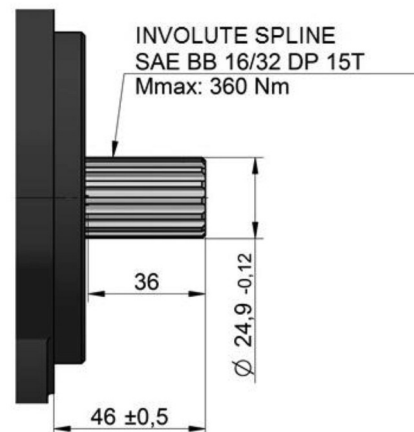

D17:

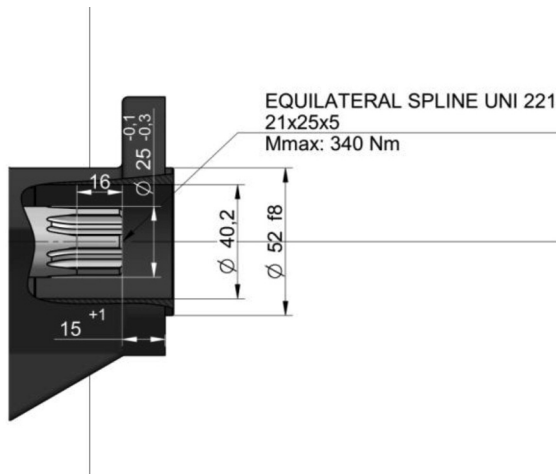

D18:

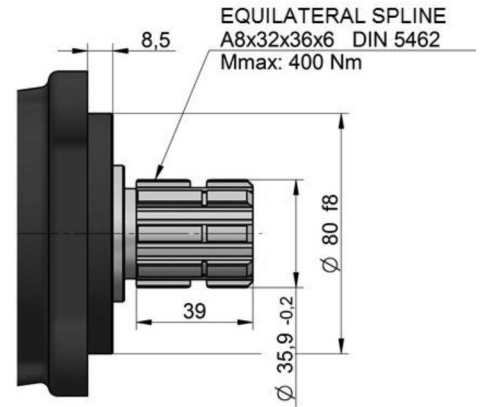

D23:

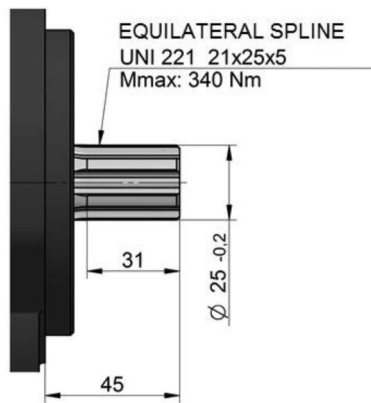

V17:

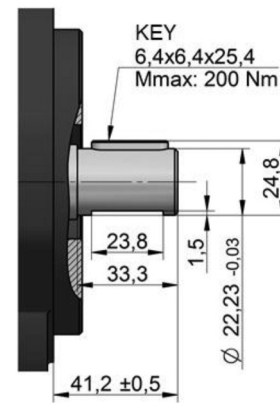

LIQUID INLET AND OUTLET CONNECTION

Metric thread according to ISO 6149

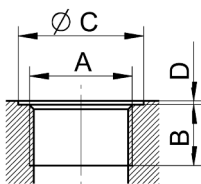

Code	A	B	C	D
M07	M 22 x 1.5	14	28	1
M08	M 27 x 1.5	16	33	1
M09	M 27 x 2.0	16	33	1
M11	M 33 x 1.5	18	40	1
M12	M 33 x 2.0	18	40	1

BSPP pipe thread according to ISO 228-1

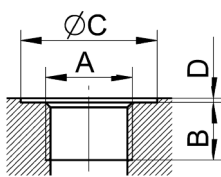

Code	A	B	C	D
G03	G 1/2"	14	33	1
G04	G 3/4"	16	39	1
G05	G 1"	18	45	1

UNF thread according to SAE

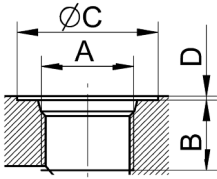

Code	A	B	C	D
U03	3/4 - 16 UNF	15	30	1
U04	7/8 - 14 UNF	17	34	1
U05	1 - 1/16 - 12 UN	19	41	1
U07	1 - 5/16 - 12 UN	19	49	1

Flanged fittings according to DIN 8901/8902

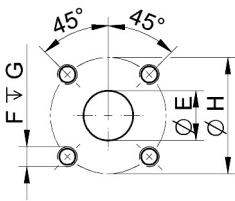

Code	E	F	G	H
H07	13.5	M6	13	30
H08	20.0	M8	16	40
H09	18.0	M8	16	55
H10	25.0	M8	16	55

Flanged fittings according to SAE, metric thread

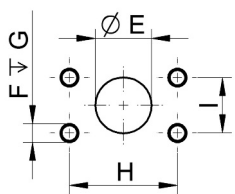

Code	E	F	G	H	I
E02	19.0	M10	22	47.6	22.2
E03	25.4	M10	22	52.4	26.2
E04	30.5	M10	22	58.7	30.2

Flanged fittings according to SAE, UNC thread

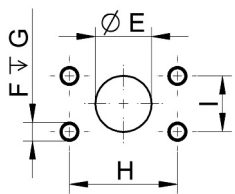

Code	E	F	G	H	I
A02	19.0	3/8-16 UNC-2B	22.0	47.6	22.2
A03	25.4	3/8-16 UNC-2B	22.0	52.4	26.2
A04	30.5	7/16-14 UNC-2B	28.5	58.7	30.2

Flanged fittings - „cross“

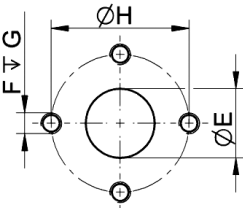

Code	E	F	G	H
K03	18	M8	16	40
K04	26	M10	22	51
K05	18	M8	16	55
K06	25	M8	16	55

Flanged fittings - „square“

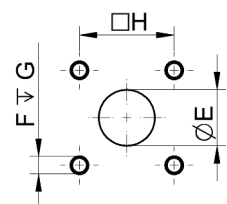

Code	E	F	G	H
S05	22	M10	22	48

CATALOGUE SHETS OF GHDO SERIES BASIC DESIGNS

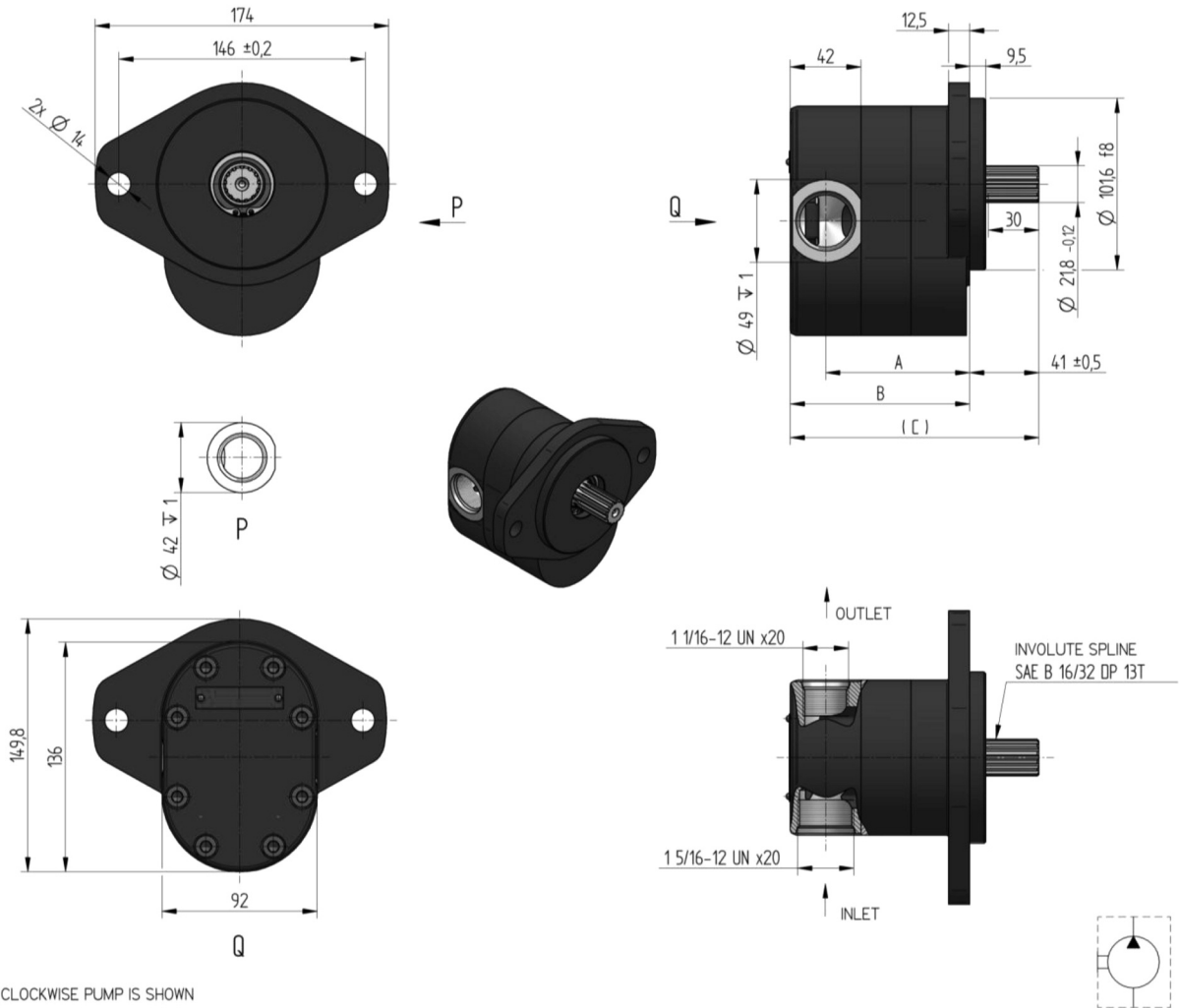

CLOCKWISE PUMP IS SHOWN

Order key	purch. code	direct. of rot.	displacement [cm ³ /1]	nom. press. [bar]	speed MIN. [min ⁻¹]	speed MAX. [min ⁻¹]	A [mm]	dimension B [mm]	C [mm]
GHDO-36R-S03D13-SU07U05-N		R	36	270	350	2800	95.8	116.8	157.8
GHDO-36L-S03D13-SU07U05-N		L							
GHDO-34R-S03D13-SU07U05-N		R	34	285	350	3000	94.3	115.3	156.3
GHDO-34L-S03D13-SU07U05-N		L							
GHDO-29R-S03D13-SU07U05-N		R	29	290	350	3200	90.4	111.4	152.4
GHDO-29L-S03D13-SU07U05-N		L							
GHDO-27R-S03D13-SU07U05-N		R	27	290	350	3400	88.8	109.8	150.8
GHDO-27L-S03D13-SU07U05-N		L							
GHDO-22.5R-S03D13-SU07U05-N		R	22.5	295	350	3400	85.3	106.3	147.3
GHDO-22.5L-S03D13-SU07U05-N		L							
GHDO-19R-S03D13-SU07U05-N		R	19	295	350	3400	82.6	103.6	144.6
GHDO-19L-S03D13-SU07U05-N		L							
GHDO-17R-S03D13-SU07U05-N		R	17	300	350	3400	81.0	102.0	143.0
GHDO-17L-S03D13-SU07U05-N		L							
GHDO-13R-S03D13-SU07U05-N		R	13	300	400	3400	77.9	98.9	139.9
GHDO-13L-S03D13-SU07U05-N		L							
GHDO-12.6R-S03D13-SU07U05-N		R	12.6	300	400	3400	77.6	98.6	139.6
GHDO-12.6L-S03D13-SU07U05-N		L							
GHDO-10R-S03D13-SU07U05-N		R	10	300	400	3400	75.6	96.6	137.6
GHDO-10L-S03D13-SU07U05-N		L							

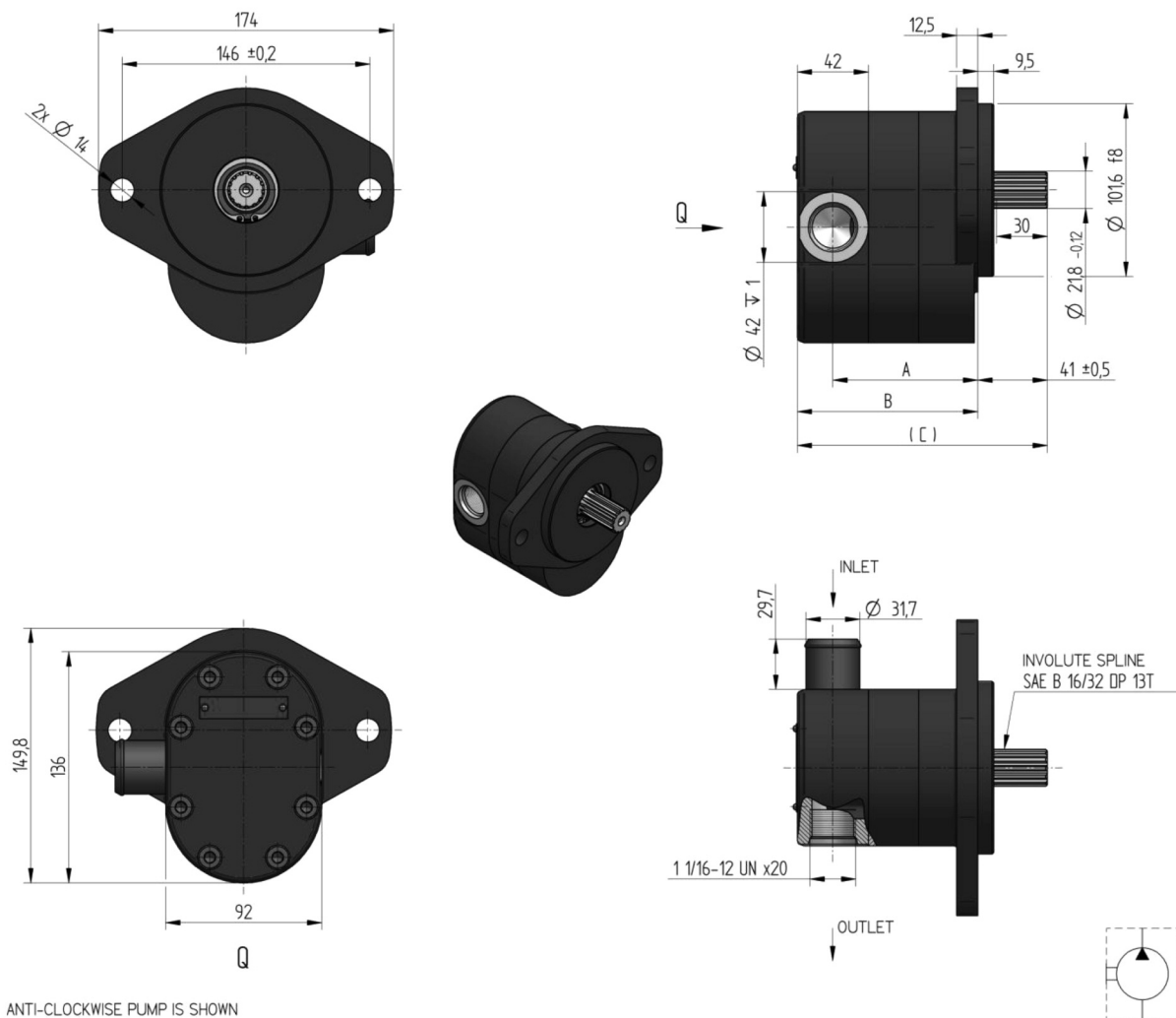

ANTI-CLOCKWISE PUMP IS SHOWN

Order key	purch. code	direct. of rot.	displacement [cm ³ /1]	nom. press. [bar]	speed MIN. [min ⁻¹]	speed MAX. [min ⁻¹]	dimension		
							A [mm]	B [mm]	C [mm]
GHDO-36R-S03D13-SZU05-N		R	36	270	350	2800	95.8	116.8	157.8
GHDO-36L-S03D13-SZU05-N		L							
GHDO-34R-S03D13-SZU05-N		R	34	285	350	3000	94.3	115.3	156.3
GHDO-34L-S03D13-SZU05-N		L							
GHDO-29R-S03D13-SZU05-N		R	29	290	350	3200	90.4	111.4	152.4
GHDO-29L-S03D13-SZU05-N		L							
GHDO-27R-S03D13-SZU05-N		R	27	290	350	3400	88.8	109.8	150.8
GHDO-27L-S03D13-SZU05-N		L							
GHDO-22.5R-S03D13-SZU05-N		R	22.5	295	350	3400	85.3	106.3	147.3
GHDO-22.5L-S03D13-SZU05-N		L							
GHDO-19R-S03D13-SZU05-N		R	19	295	350	3400	82.6	103.6	144.6
GHDO-19L-S03D13-SZU05-N		L							
GHDO-17R-S03D13-SZU05-N		R	17	300	350	3400	81.0	102.0	143.0
GHDO-17L-S03D13-SZU05-N		L							
GHDO-13R-S03D13-SZU05-N		R	13	300	400	3400	77.9	98.9	139.9
GHDO-13L-S03D13-SZU05-N		L							
GHDO-12.6R-S03D13-SZU05-N		R	12.6	300	400	3400	77.6	98.6	139.6
GHDO-12.6L-S03D13-SZU05-N		L							
GHDO-10R-S03D13-SZU05-N		R	10	300	400	3400	75.6	96.6	137.6
GHDO-10L-S03D13-SZU05-N		L							

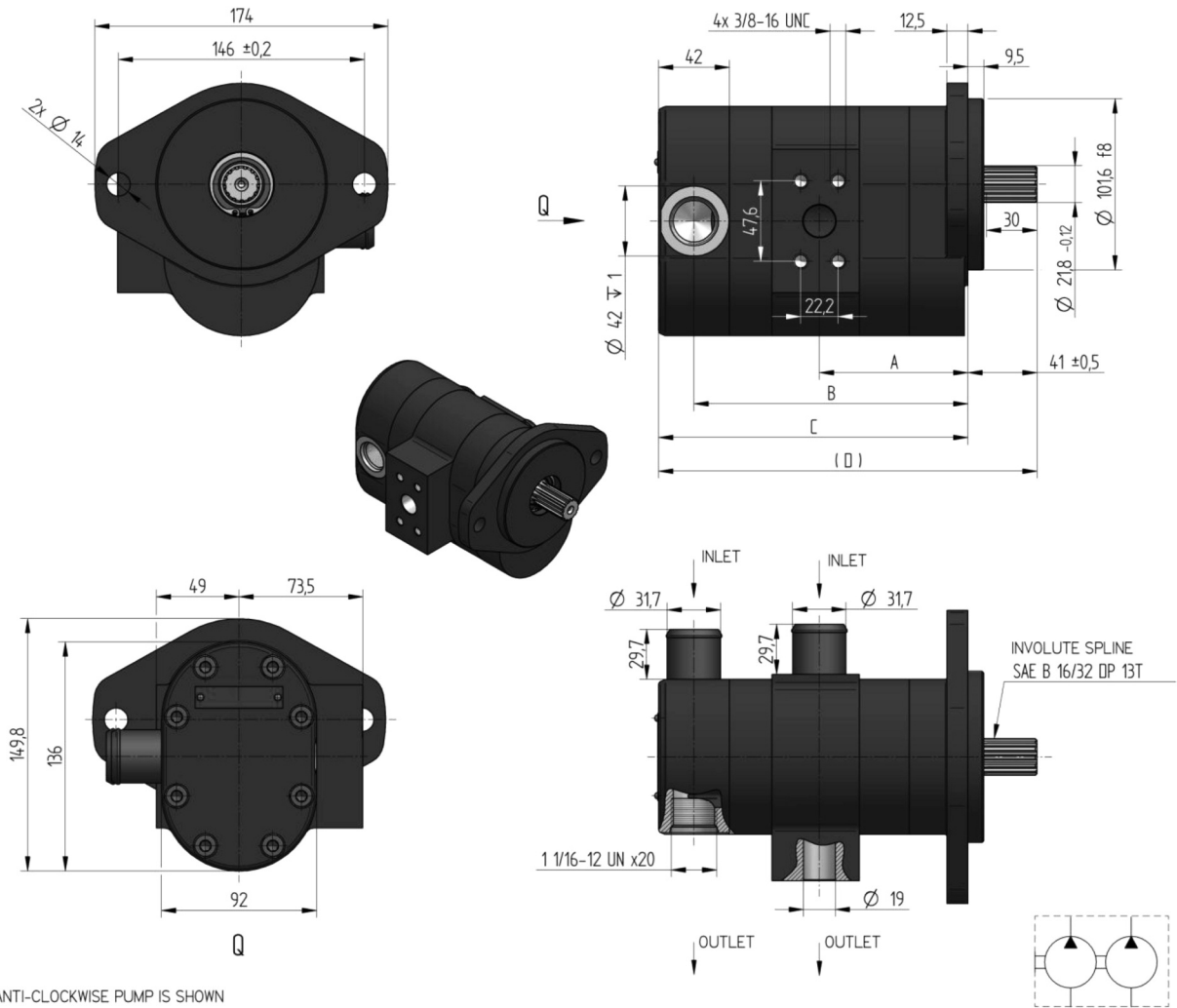

ANTI-CLOCKWISE PUMP IS SHOWN

Order key	purch. code	direct. of rot.	displacement [cm ³ /1]	nom. press. [bar]	speed MIN. [min ⁻¹]	speed MAX. [min ⁻¹]	dimension			
							A [mm]	B [mm]	C [mm]	D [mm]
GHDO-22.5/17R-S03D13-SZA02/ZU05-N		R	22.5/17	295/300	350	3400	88.1	162.5	183.5	224.5
GHDO-22.5/17L-S03D13-ST02A02/T02U05-V	188 9400	L								

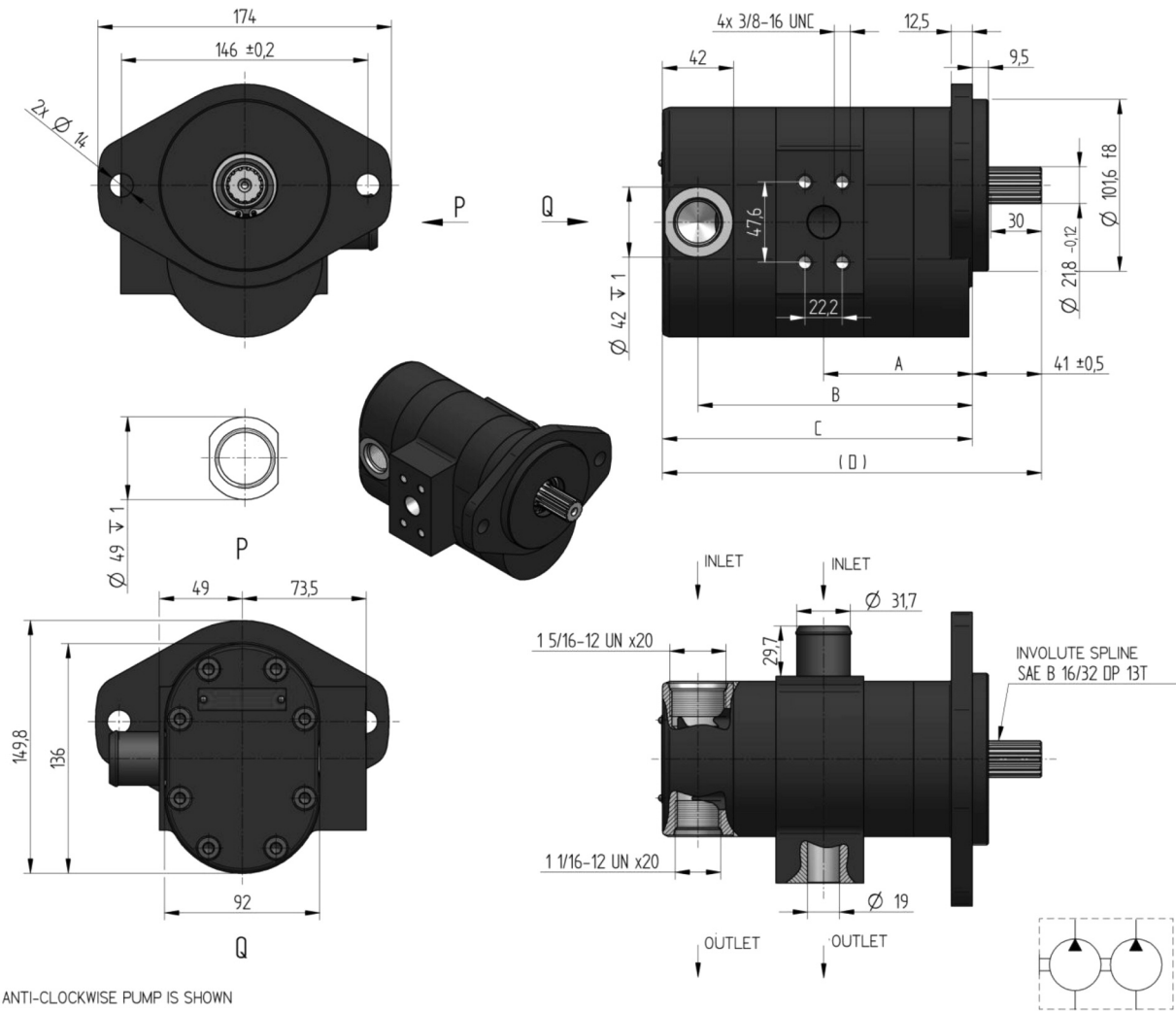

ANTI-CLOCKWISE PUMP IS SHOWN

Order key	purch. code	direct. of rot.	displacement [cm ³ /1]	nom. press. [bar]	speed MIN. [min ⁻¹]	speed MAX. [min ⁻¹]	dimension			
							A [mm]	B [mm]	C [mm]	D [mm]
GHDO-22.5/17R-S03D13-SZA02/U07U05-N		R	22.5/17	295/300	350	3400	88.1	162.5	183.5	224.5
GHDO-22.5/17L-S03D13-ST02A02/U07U05-V	188 9401	L								

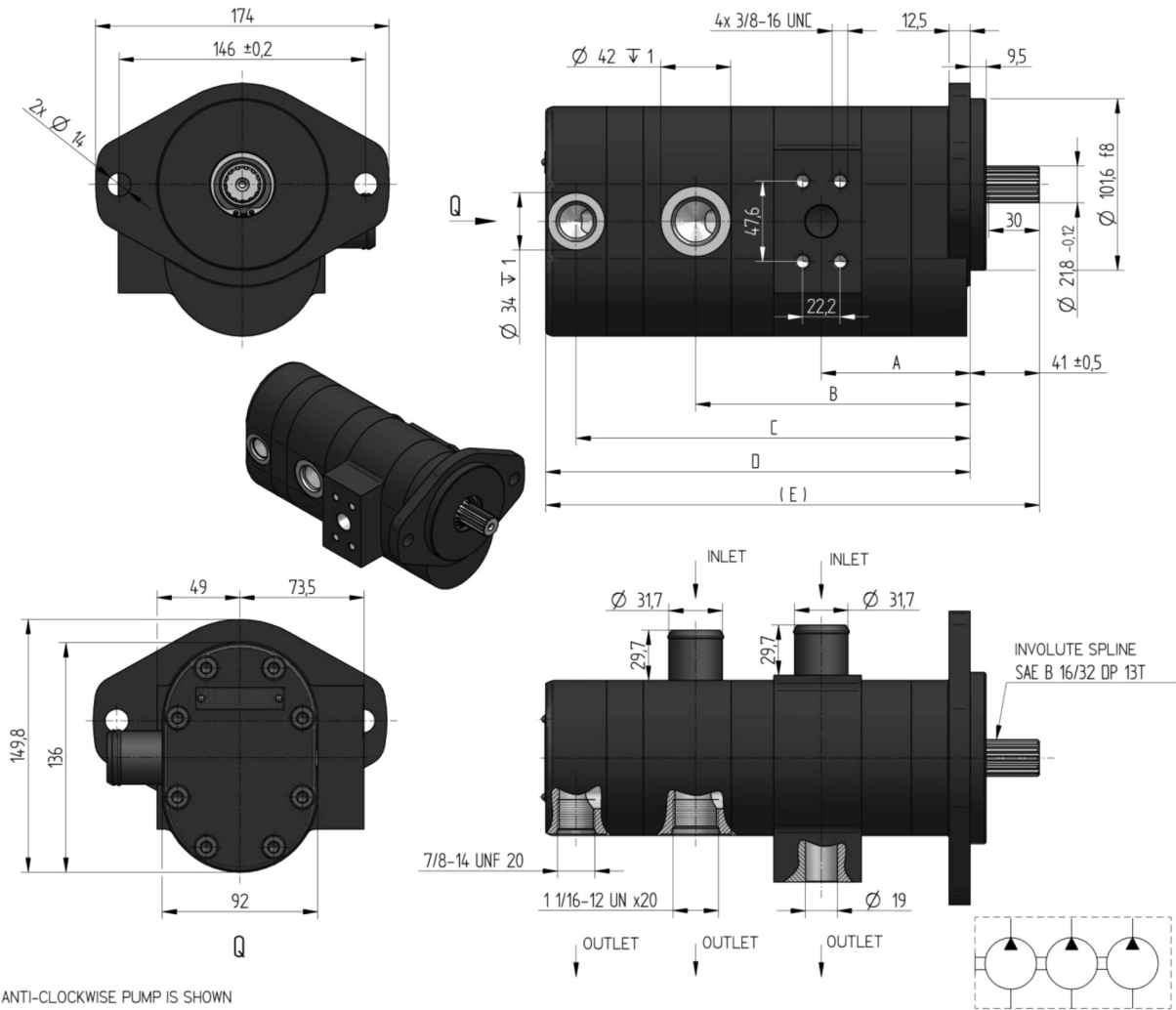

ANTI-CLOCKWISE PUMP IS SHOWN

Order key	purch. code	direct. of rot.	displacement [cm ³ /1]	nom. press. [bar]	speed MIN. [min ⁻¹]	speed MAX. [min ⁻¹]	dimension				
							A [mm]	B [mm]	C [mm]	D [mm]	E [mm]
GHDO-22.5/17/12.6R-S03D13-SZA02/ZU05/NU04-N		R	22.5/17	295/300	350	3400	88.1	162.5	233.3	251.3	292.3
GHDO-22.5/17/12.6L-S03D13-SZA02/ZU05/NU04-N		L	/12.6	/300							

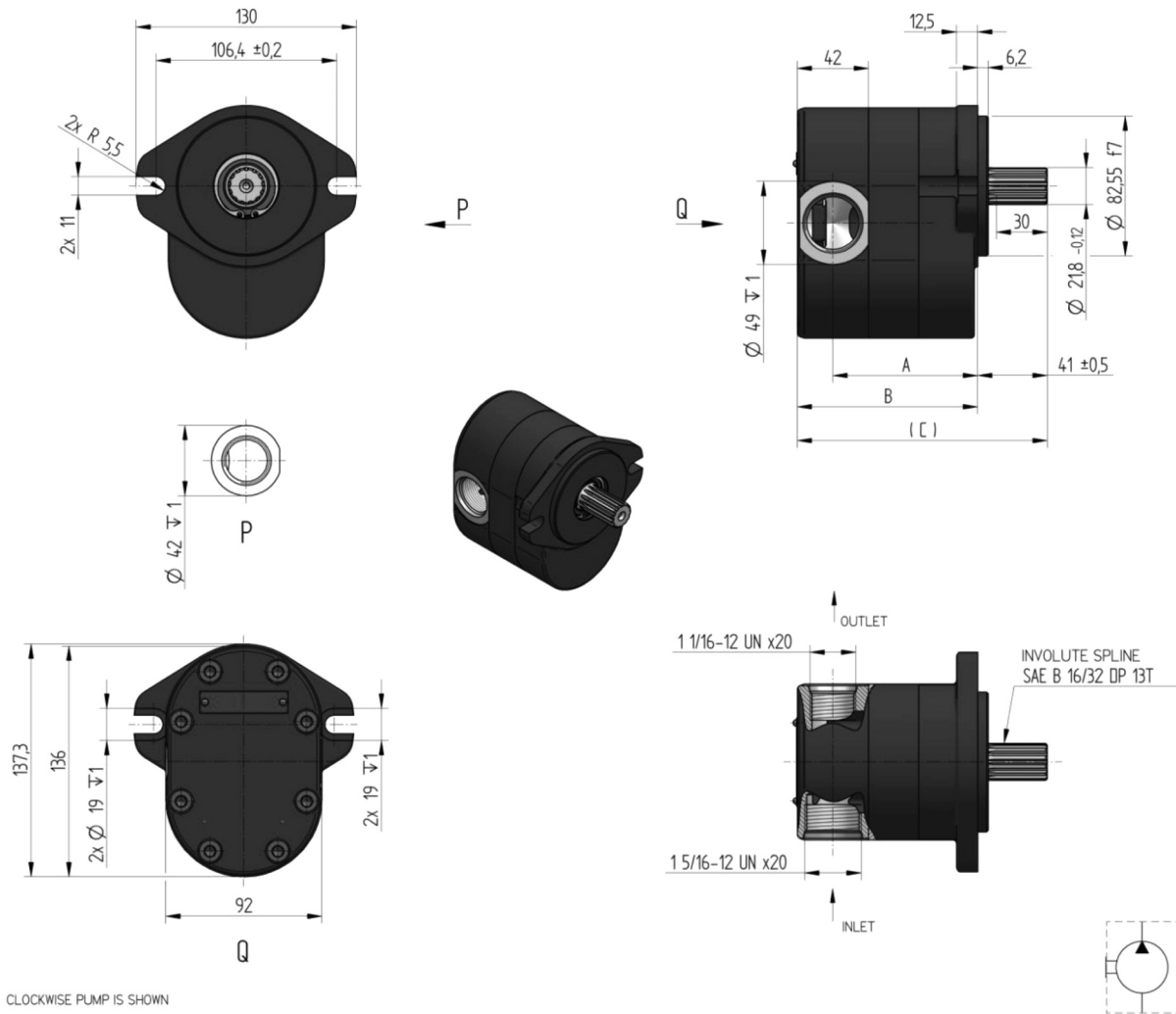

CLOCKWISE PUMP IS SHOWN

Order key	purch. code	direct. of rot.	displacement [cm ³ /1]	nom. press. [bar]	speed MIN. [min ⁻¹]	speed MAX. [min ⁻¹]	A [mm]	dimension B [mm]	C [mm]
GHDO-36R-S02D13-SU07U05-N		R	36	270	350	2800	95.8	116.8	157.8
GHDO-36L-S02D13-SU07U05-N		L							
GHDO-34R-S02D13-SU07U05-N		R	34	285	350	3000	94.3	115.3	156.3
GHDO-34L-S02D13-SU07U05-N		L							
GHDO-29R-S02D13-SU07U05-N		R	29	290	350	3200	90.4	111.4	152.4
GHDO-29L-S02D13-SU07U05-N		L							
GHDO-27R-S02D13-SU07U05-N		R	27	290	350	3400	88.8	109.8	150.8
GHDO-27L-S02D13-SU07U05-N		L							
GHDO-22.5R-S02D13-SU07U05-N		R	22.5	295	350	3400	85.3	106.3	147.3
GHDO-22.5L-S02D13-SU07U05-N		L							
GHDO-19R-S02D13-SU07U05-N		R	19	295	350	3400	82.6	103.6	144.6
GHDO-19L-S02D13-SU07U05-N		L							
GHDO-17R-S02D13-SU07U05-N		R	17	300	350	3400	81.0	102.0	143.0
GHDO-17L-S02D13-SU07U05-N		L							
GHDO-13R-S02D13-SU07U05-N		R	13	300	400	3400	77.9	98.9	139.9
GHDO-13L-S02D13-SU07U05-N		L							
GHDO-12.6R-S02D13-SU07U05-N		R	12.6	300	400	3400	77.6	98.6	139.6
GHDO-12.6L-S02D13-SU07U05-N		L							
GHDO-10R-S02D13-SU07U05-N		R	10	300	400	3400	75.6	96.6	137.6
GHDO-10L-S02D13-SU07U05-N		L							

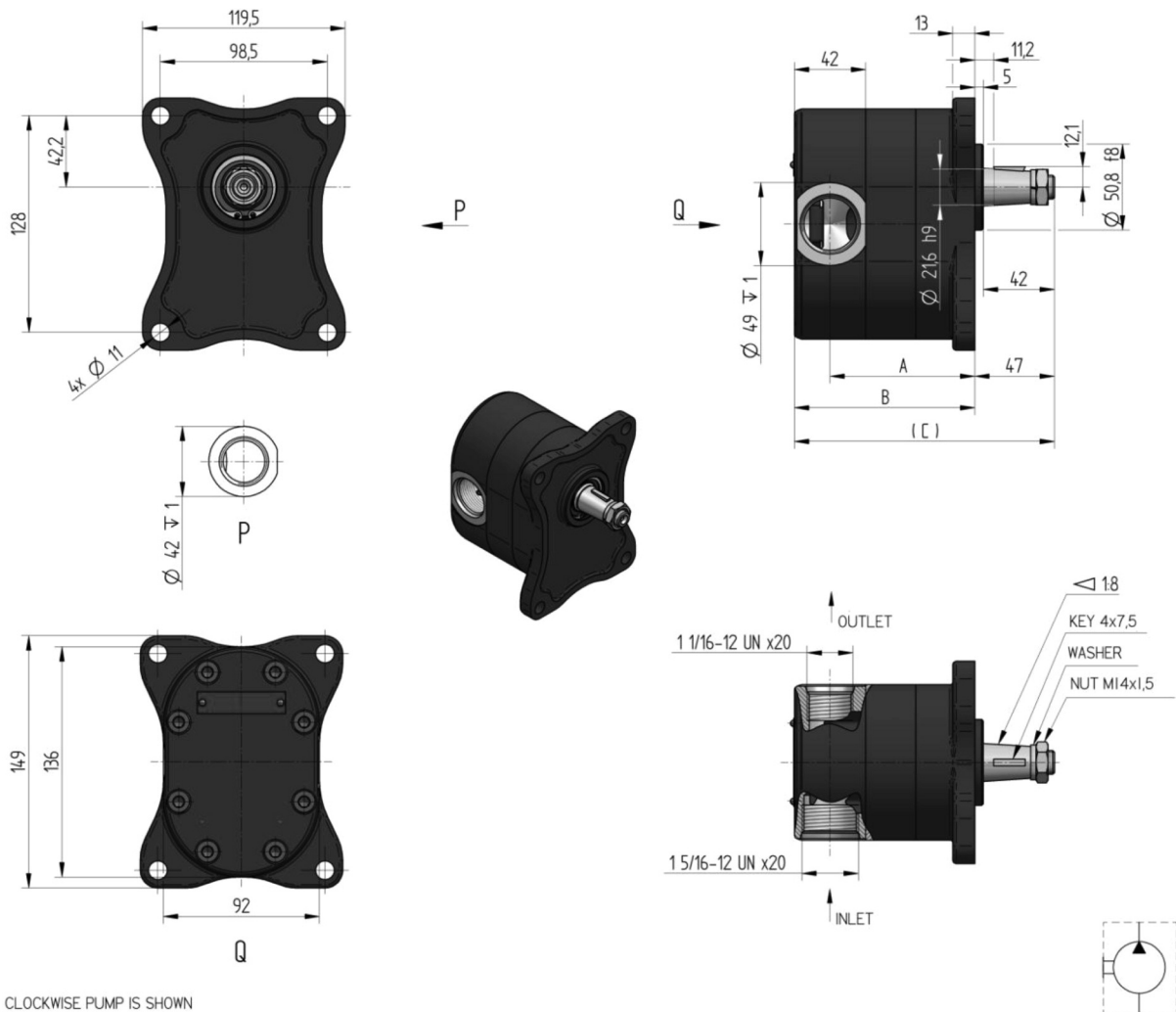

CLOCKWISE PUMP IS SHOWN

Order key	purch. code	direct. of rot.	displacement [cm ³ /1]	nom. press. [bar]	speed MIN. [min ⁻¹]	speed MAX. [min ⁻¹]	dimension		
							A [mm]	B [mm]	C [mm]
GHDO-36R-R11C11-SU07U05-N		R	36	270	350	2800	95.8	116.8	163.8
GHDO-36L-R11C11-SU07U05-N		L							
GHDO-34R-R11C11-SU07U05-N		R	34	285	350	3000	94.3	115.3	162.3
GHDO-34L-R11C11-SU07U05-N		L							
GHDO-29R-R11C11-SU07U05-N		R	29	290	350	3200	90.4	111.4	158.4
GHDO-29L-R11C11-SU07U05-N		L							
GHDO-27R-R11C11-SU07U05-N		R	27	290	350	3400	88.8	109.8	156.8
GHDO-27L-R11C11-SU07U05-N		L							
GHDO-22.5R-R11C11-SU07U05-N		R	22.5	295	350	3400	85.3	106.3	153.3
GHDO-22.5L-R11C11-SU07U05-N		L							
GHDO-19R-R11C11-SU07U05-N		R	19	295	350	3400	82.6	103.6	150.6
GHDO-19L-R11C11-SU07U05-N		L							
GHDO-17R-R11C11-SU07U05-N		R	17	300	350	3400	81.0	102.0	149.0
GHDO-17L-R11C11-SU07U05-N		L							
GHDO-13R-R11C11-SU07U05-N		R	13	300	400	3400	77.9	98.9	145.9
GHDO-13L-R11C11-SU07U05-N		L							
GHDO-12.6R-R11C11-SU07U05-N		R	12.6	300	400	3400	77.6	98.6	145.6
GHDO-12.6L-R11C11-SU07U05-N		L							
GHDO-10R-R11C11-SU07U05-N		R	10	300	400	3400	75.6	96.6	143.6
GHDO-10L-R11C11-SU07U05-N		L							

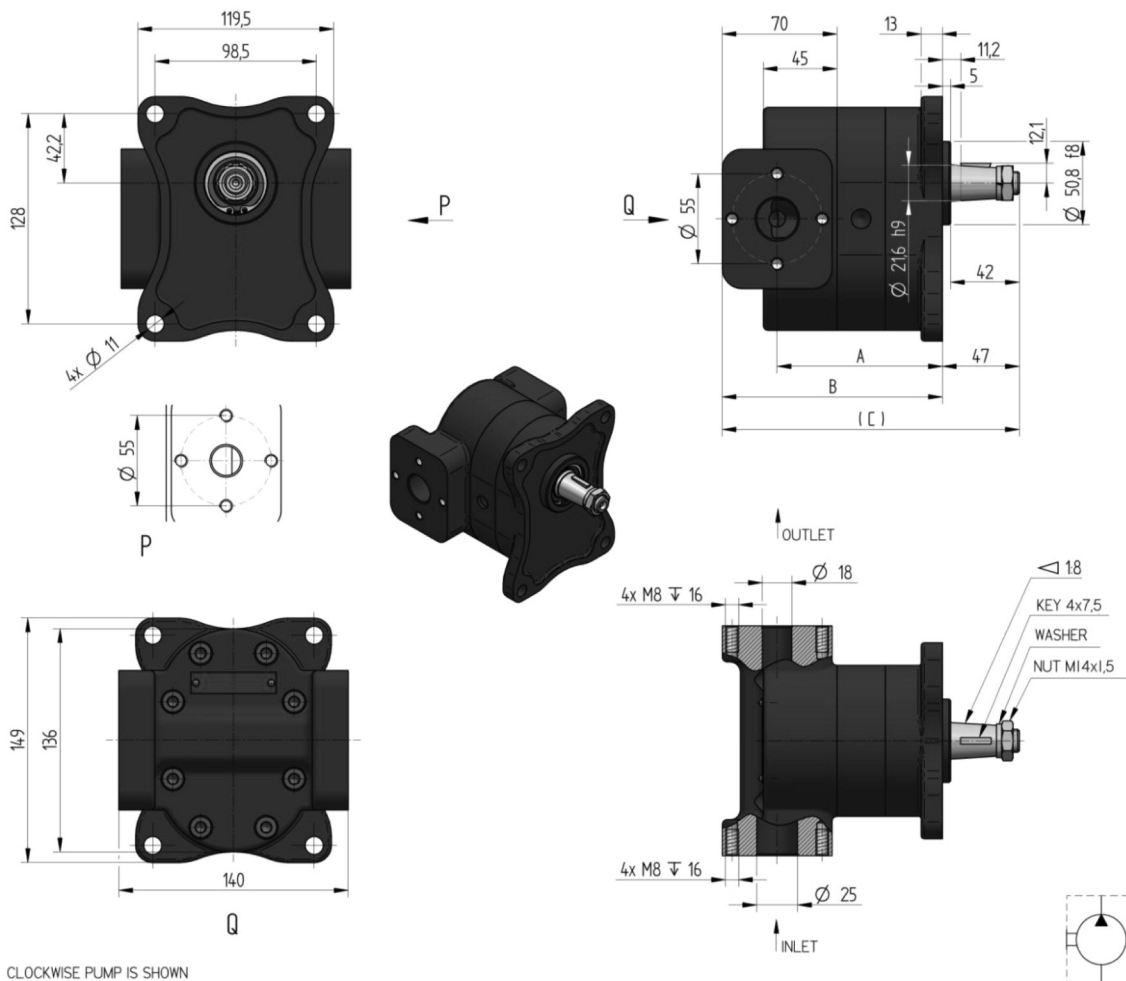

Order key	purch. code	direct. of rot.	displacement [cm ³ /1]	nom. press. [bar]	speed MIN. [min ⁻¹]	speed MAX. [min ⁻¹]	dimension		
							A [mm]	B [mm]	C [mm]
GHDO-36R-R11C11-SK06K05-N		R	36	270	350	2800	111.3	144.8	191.8
GHDO-36L-R11C11-SK06K05-N		L							
GHDO-34R-R11C11-SK06K05-N		R	34	285	350	3000	109.8	143.3	190.3
GHDO-34L-R11C11-SK06K05-N		L							
GHDO-29R-R11C11-SK06K05-N		R	29	290	350	3200	105.9	139.4	186.4
GHDO-29L-R11C11-SK06K05-N		L							
GHDO-27R-R11C11-SK06K05-N		R	27	290	350	3400	104.3	137.8	184.8
GHDO-27L-R11C11-SK06K05-N		L							
GHDO-22.5R-R11C11-SK06K05-N		R	22.5	295	350	3400	100.8	134.3	181.3
GHDO-22.5L-R11C11-SK06K05-N		L							
GHDO-19R-R11C11-SK06K05-N		R	19	295	350	3400	98.1	131.6	178.6
GHDO-19L-R11C11-SK06K05-N		L							
GHDO-17R-R11C11-SK06K05-N		R	17	300	350	3400	96.5	130.0	177.0
GHDO-17L-R11C11-SK06K05-N		L							
GHDO-13R-R11C11-SK06K05-N		R	13	300	400	3400	93.4	126.9	173.9
GHDO-13L-R11C11-SK06K05-N		L							
GHDO-12.6R-R11C11-SK06K05-N		R	12.6	300	400	3400	93.1	126.6	173.6
GHDO-12.6L-R11C11-SK06K05-N		L							
GHDO-10R-R11C11-SK06K05-N		R	10	300	400	3400	91.1	124.6	171.6
GHDO-10L-R11C11-SK06K05-N		L							

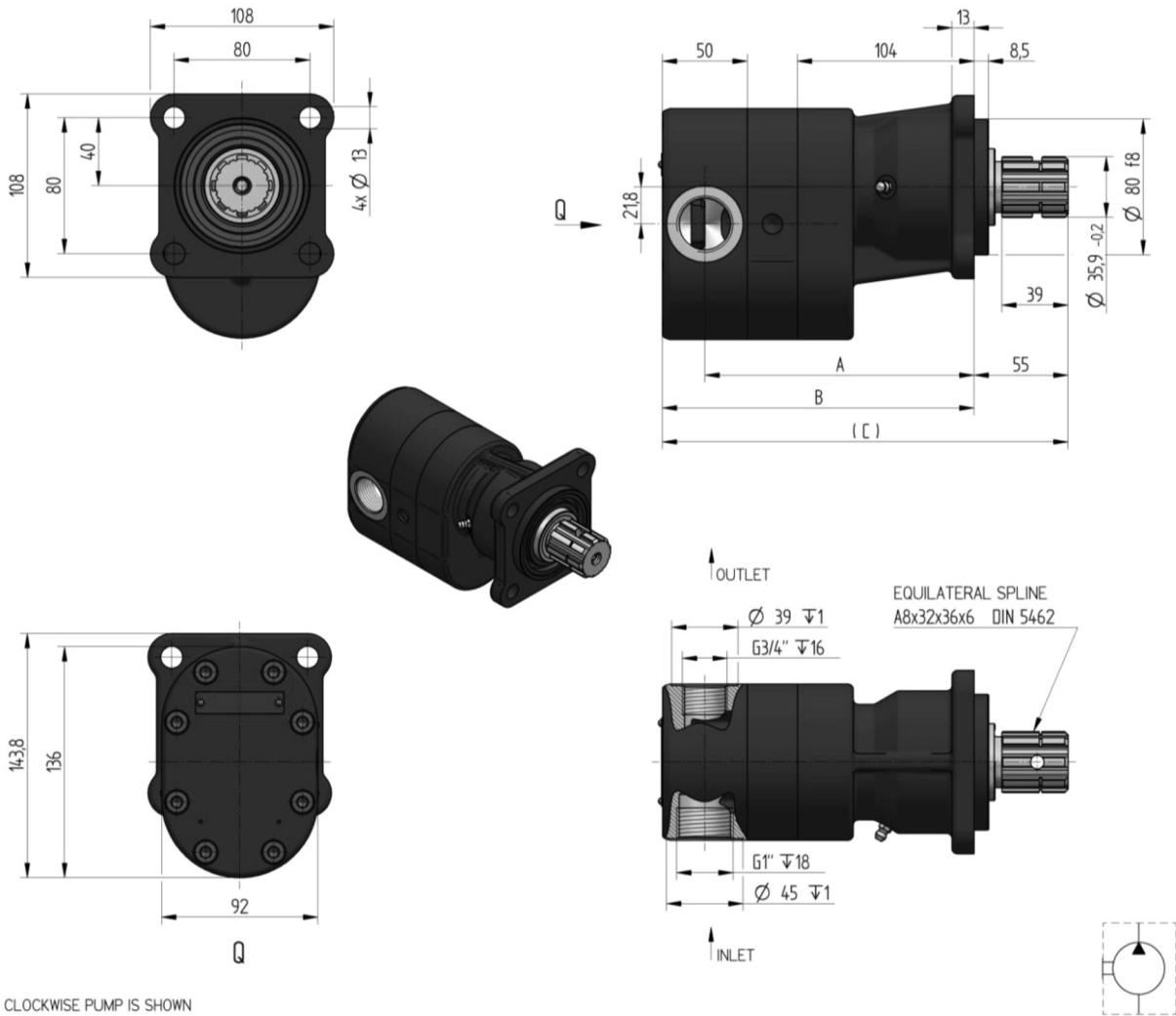

CLOCKWISE PUMP IS SHOWN

Order key	purch. code	direct. of rot.	displacement [cm ³ /1]	nom. press. [bar]	speed MIN. [min ⁻¹]	speed MAX. [min ⁻¹]	A [mm]	dimension B [mm]	C [mm]
GHDO-36R-I02D18-SG05G04-N.001		R	36	270	350	2800	169.0	194.0	249.0
GHDO-36L-I02D18-SG05G04-N.001		L							
GHDO-34R-I02D18-SG05G04-N.001		R	34	285	350	3000	167.5	192.5	247.5
GHDO-34L-I02D18-SG05G04-N.001		L							
GHDO-29R-I02D18-SG05G04-N.001		R	29	290	350	3200	163.6	188.6	243.6
GHDO-29L-I02D18-SG05G04-N.001		L							
GHDO-27R-I02D18-SG05G04-N.001		R	27	290	350	3400	162.0	187.0	242.0
GHDO-27L-I02D18-SG05G04-N.001		L							
GHDO-22.5R-I02D18-SG05G04-N.001		R	22.5	295	350	3400	158.5	183.5	238.5
GHDO-22.5L-I02D18-SG05G04-N.001		L							
GHDO-19R-I02D18-SG05G04-N.001		R	19	295	350	3400	155.8	180.8	235.8
GHDO-19L-I02D18-SG05G04-N.001		L							
GHDO-17R-I02D18-SG05G04-N.001		R	17	300	350	3400	154.2	179.2	234.2
GHDO-17L-I02D18-SG05G04-N.001		L							
GHDO-13R-I02D18-SG05G04-N.001		R	13	300	400	3400	151.1	176.1	231.1
GHDO-13L-I02D18-SG05G04-N.001		L							
GHDO-12.6R-I02D18-SG05G04-N.001		R	12.6	300	400	3400	150.8	175.8	230.8
GHDO-12.6L-I02D18-SG05G04-N.001		L							
GHDO-10R-I02D18-SG05G04-N.001		R	10	300	400	3400	148.8	173.8	228.8
GHDO-10L-I02D18-SG05G04-N.001		L							

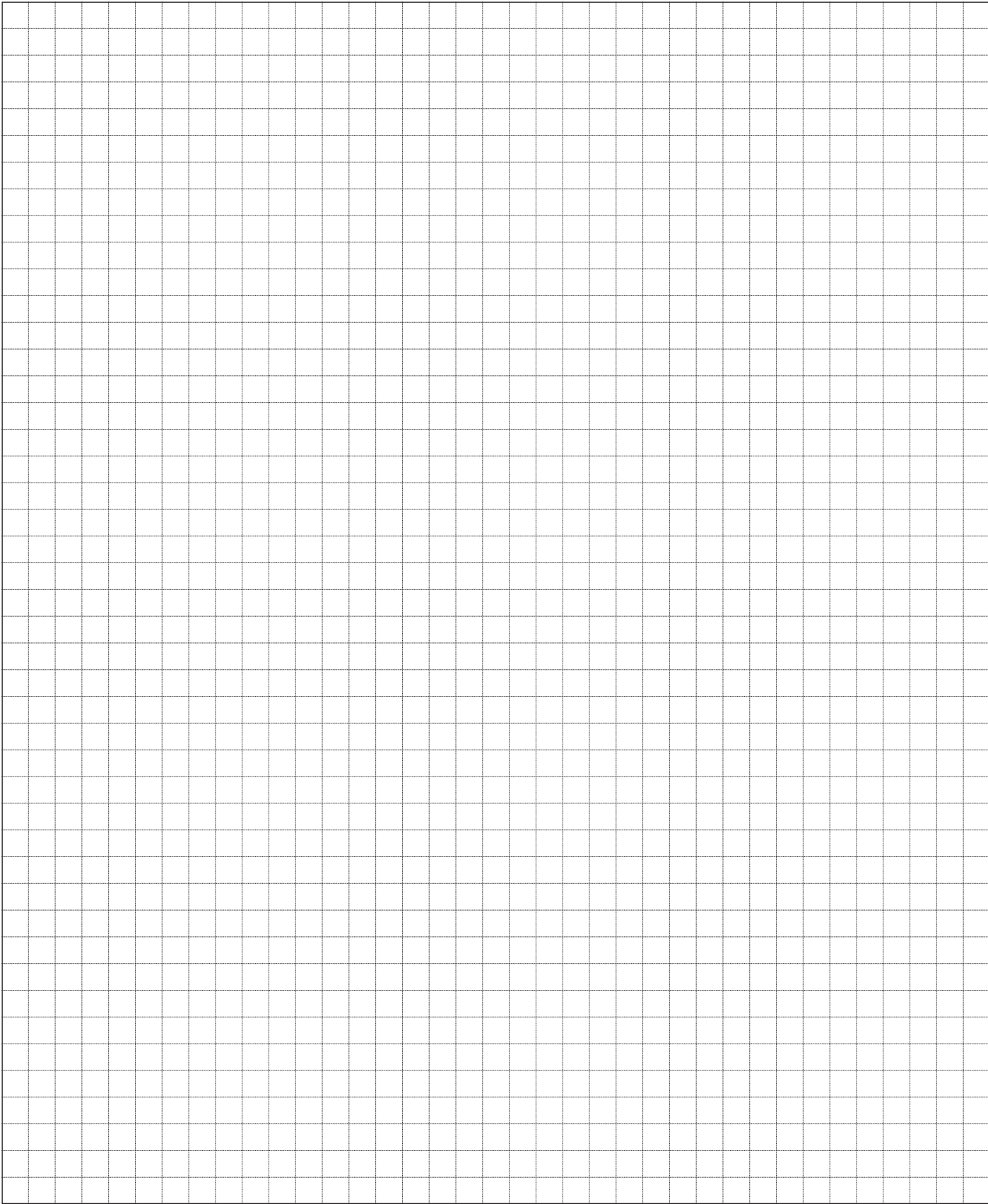

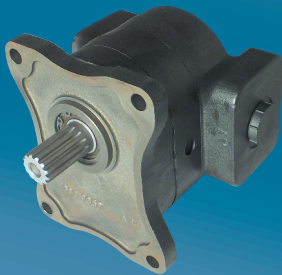
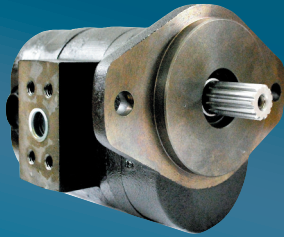

jihostroj
AERO TECHNOLOGY & HYDRAULICS

JIHOSTROJ a.s.
Budějovická 148
CZ 382 32 Velešín
Czech Republic
tel.: +420 380 340 511
fax: +420 380 340 612
e-mail: mailbox@jihostroj.cz
http: //www.jihostroj.com

GPS 48°49'51.748" N 14°27'40.770" E

